

design2machine

btl interface description

Version: 10.2

Build: 10200

Last modified: 14.05.2009

Common Data Interface for Wood Working Machines

The following interface description is designed for the structured representation of the data relevant to the manufacturing process.

It does not contain any machine specific data. This allows the interface to be used as a common data interface.

If there is a need to prepare the data stored in this interface for some special wood working machine or some special control, then these data should be imported by a suitable CAM system and then properly processed.

Content	page
0. Interface Architecture	I
1. Basic Structure of the btl-File	II
2. Caption	VII
3. Example File	X
4. Table of Contents, List of Construction Forms	XII
5. History	XIII

0. Interface Architecture

The file described herein is identified by the ".btl" extension.

It contains general data related to the Project as well as parameter descriptions of the construction forms to be transferred to the wood working machines.

For more information or questions regarding the btl format, please contact:

cadwork informatik Software GmbH
Lavesstrasse4
D-31137 Hildesheim
Tel: +49-5121-919990
Fax: +49-5121-919960
info@cadwork.de
www.cadwork.com

SEMA GmbH
Dorfmühlstr. 7-11
D-87499 Wildpoldsried
Tel: +49 (0)8304 9390
Fax: +49 (0)8304 939244
sema@sema-soft.com
www.sema-soft.com

1. Basic Structure of the btl-File

General: IDENTIFICATION INDEX : Values

Identification Index	Datatyp	Meaning
VERSION: BUILD:	BTL V10.2 (String) 10200 (String)	Version number Build number
[GENERAL]		
PROJECTNUMBER: PROJECTNAME: PROJECTPART: LISTNAME: CUSTOMER: ARCHITECT: EDITOR: DELIVERYDATE: EXPORTDATE: EXPORTTIME: EXPORTRELEASE: LANGUAGE: SCALEUNIT: PROCESSINGQUALITY: COMPUTERNAME: USER: SOURCEFILE: EXPORTFILE: RECESS:	String max.256 characters String max.256 characters String max.256 characters String max.256 characters String max.256 characters String max.256 characters String max.256 characters String max.256 characters String max.256 characters String max.256 characters String max.256 characters String max.256 characters Integer VISIBLE or FAST String max.256 characters String max.256 characters String max.256 characters String max.256 characters AUTOMATIC	Project number Project name Project part Listname Customer Architect Editor name Delivery date Export date Export time Export release Language Number of decimals for all values with datatype "String 8 characters". See 2. Caption / 8. SCALEUNIT Describes the quality of the project. Computername User name Path and name of the CAD-File Path and name of the BTL-File If this parameter is set, the processing must be done completely. If not, there could be some additional manual work. complete additional manual work RECESS: AUTOMATIC 
COMMENT:	String max.256 characters	Comment. This line may appear several times.

Identification Index	Datatyp	Meaning
<p><i>Loop over the rawparts</i> [RAWPART]</p>		
<p>The rawpart has the same parameters as a part. A rawpart can contain several parts. Each part can be defined with the processkey 0-300-1. The processings of the part are declared in the part-definition. A rawpart can have own processings. In the BTL-File first the rawparts are declared, then the parts.</p> <div data-bbox="847 551 1453 824" style="border: 1px solid green; padding: 5px;"> </div>		
<p><i>Loop over the processings for rawpart</i></p>		
PROCESSKEY:	0-300-1	With this key a part is set to the rawpart.
REFERENCEPLANE:	OX: String 8 characters OY: String 8 characters OZ: String 8 characters XX: String 8 characters XY: String 8 characters XZ: String 8 characters YX: String 8 characters YY: String 8 characters YZ: String 8 characters	Coordinate triple origin of the part-coordinate-system Direction vector of the local x axis Direction vector of the local y axis
PROCESSPARAMETERS:	P09: String 8 characters	Singelmembern timer of the part
<p><i>End of loop over the processings for rawpart</i></p>		
<p><i>End of loop over the rawparts</i></p>		

Identification Index	Datatypes	Meaning
<i>Loop over the parts</i> [PART]		
SINGLEMEMBERNUMBER: ASSEMBLYNUMBER: ORDERNUMBER: DESIGNATION: ANNOTATION: STOREY: GROUP: PACKAGE: MATERIAL: TIMBERGRADE: QUALITYGRADE: COUNT: LENGTH: HEIGHT: WIDTH: COLOUR:	Integer String max.256 characters Integer String max.256 characters String max.256 characters String max.256 characters String max.256 characters String max.256 characters String max.256 characters String max.256 characters String max.256 characters Integer String 8 characters String 8 characters String 8 characters R: Integer G: Integer B: Integer A: Integer	Production number Assembly list number Order list number Name Comment Subgroup Group Delivery package Material Timbergrade Qualitygrade Count Length Height Width Colour of the part. Values from 0 to 255 are possible.
PLANINGLENGTH: STARTOFFSET: ENDOFFSET: TRANSFORMATION:	String 8 characters String 8 characters String 8 characters OX: String 8 characters OY: String 8 characters OZ: String 8 characters XX: String 8 characters XY: String 8 characters XZ: String 8 characters YX: String 8 characters YY: String 8 characters YZ: String 8 characters	Transparency Planinglength Start offset End offset Coordinate triple origin of the part-coordinate-system Direction vector of the local x axis Direction vector of the local y axis Identifier TRANSFORMATION is optional. If it is not set, the parameters will have these values: OX/OY/OZ = 0/0/0 XX/XY/XZ = 1/0/0 YX/YY/YZ = 0/1/0 There can be additional TRANSFORMATION lines for one part to see identical parts at different positions several times in the viewer.
CAMBER:	SIDE: Integer (1,2,3,4) P01: String 8 characters P02: String 8 characters P03: String 8 characters P04: String 8 characters	Side of part, reference side Distance from beam start to the first point of the arc on the centerline Distance from beam start to the second point of the arc on the centerline Distance from beam start to the third point of the arc on the centerline Camber at third point

Identification Index	Datotyp	Meaning
PARTOFFSET:	P04: String 8 characters P11: String 8 characters P12: String 8 characters P13: String 8 characters P14: String 8 characters	Number of reference side placed on fix clamp Offset on reference side 1 Offset on reference side 2 Offset on reference side 3 Offset on reference side 4
PROCESSINGQUALITY:	VISIBLE or FAST	Describes the quality of this part. The quality of the part overrides the quality of the project.
OUTLINE:	SIDE: Integer (1,2,3,4) PROCESS: YES or NO P01: String 8 characters P02: String 8 characters P03: String 8 characters P08: String 8 characters P10: String 8 characters P11: String 8 characters P12: String 8 characters	Side on which the outline is defined. OUTLINE does not refer to a refernceplane. If PROCESS is set to YES, then the outline must be machined. If it is set to NO, then the outline is an information about the shape of the workpart. This parameter must appear at the first segment (= point) and is valid for the whole outline. Start- / Endpoint. Type of line. Point on arc. <i>For details see processing 4-250-X contour. The whole outline is composed of several OUTLINE declarations in the part.</i>
RECESS:	AUTOMATIC	If this parameter is set, the processing must be done completely. If not, there could be some additional manual work. The recess of the part overrides the recess of the project.
COMMENT:	String max.256 characters	Comment. This line may appear several times.

General: IDENTIFICATION INDEX Values

Identification Index	Values (format)	Meaning
<i>Loop over the processings</i>		
PROCESSKEY:	Key with format: G-KEY-S Example: 3-040-2	G Group: 1,2: separating Group: 3,4: lying between KEY Key of construction form S Side of part, reference side
REFERENCEPLANE:	OX: String 8 characters OY: String 8 characters OZ: String 8 characters XX: String 8 characters XY: String 8 characters XZ: String 8 characters YX: String 8 characters YY: String 8 characters YZ: String 8 characters	Coordinate triple origin of the referenceside-coordinate-system Direction vector of the local x axis Direction vector of the local y axis Identifier REFERENCEPLANE is optional. If it is not set, the parameters will have these values: OX/OY/OZ = 0/0/0 XX/XY/XZ = 1/0/0 YX/YY/YZ = 0/1/0
PROCESSPARAMETERS:	P01: String 8 characters P02: String 8 characters ...	Construction form parameters. Number and meaning of the parameters depend on the construction form to be described. See the following documentation.
PROCESSIDENT:	Integer	Sequential number. This value appears only once in a piece, but can be set again in an other piece.
PROCESSINGQUALITY:	VISIBLE or FAST	Describes the quality for this construction form. The quality of the processing overrides the quality of the part and the project.
COMMENT:	String max.256 characters	Comment. This line may appear several times.
PRIORITY:	Integer	Processings with high values must be done first. Processings with low values must be done last. If priority is not set, it is assumed to be zero. If two processing have the same priority, the machine can decide in what order the processings should be done.
RECESS:	AUTOMATIC	If this parameter is set, the processing must be done completely. If not, there could be some additional manual work. The recess of the processing overrides the recess of the part and the project.
<i>End of loop over the processings</i>		
<i>End of loop over the parts</i>		

2. Caption

1. Part coordinate system

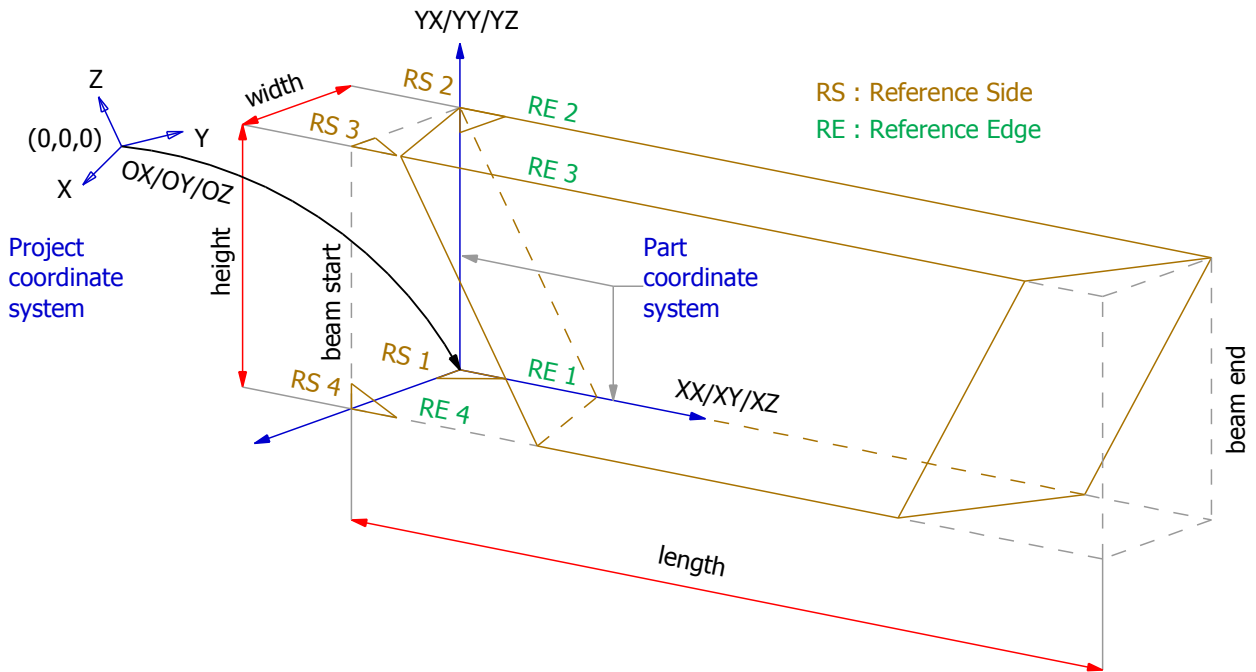

2. Referenceplane

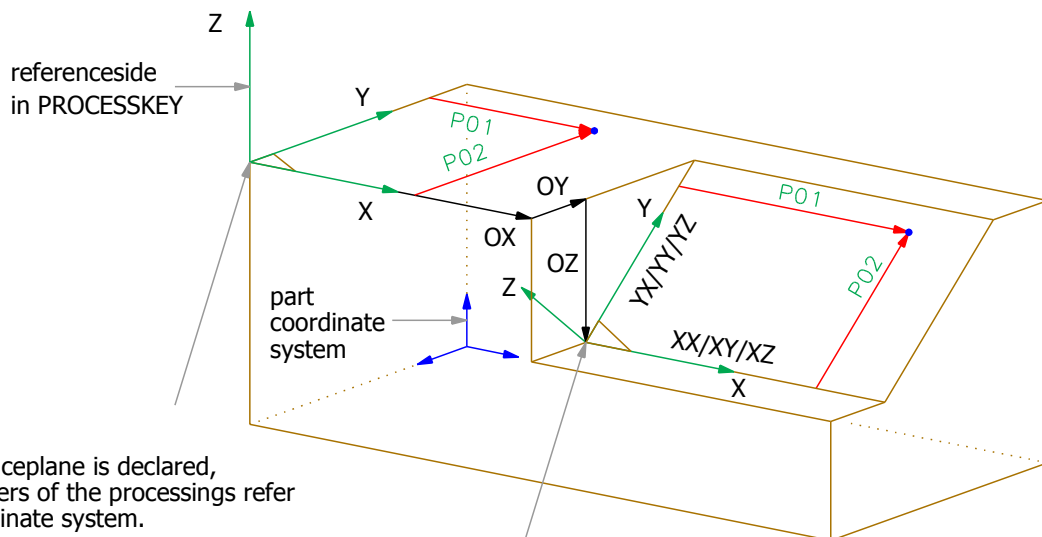

If no referenceplane is declared, the parameters of the processings refer to this coordinate system.

If there is a referenceplane declared, the parameters of the processings refer to this coordinate system.

The referenceplane refers to the referenceside, which is defined in the PROCESSKEY. If the referenceside in the PROCESSKEY is zero, the referenceplane refers to the part coordinate system.

3. These abbreviations are used in the description of the parameters:

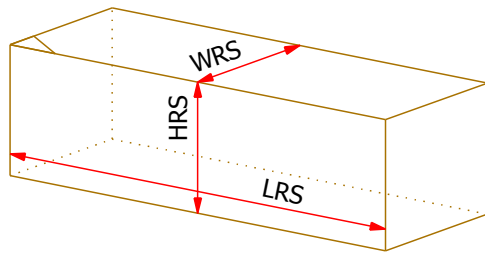

- WRS Width of Reference Side
- HRS Height of Reference Side or "other" component dimension
- LRS Length of Reference Side
Length of component

- 4. All parameters are described with a red line or a red arrow.
- 5. The parameters are shown with their positive value, if there is no special comment like (<0) or (-)
- 6. The values in the presettings mean "mm" or "degree".
- 7. Most of the processings are drawn by a view orthogonal to the reference side.
Otherwise the zeropoint of the reference side is displayed with a brown line.

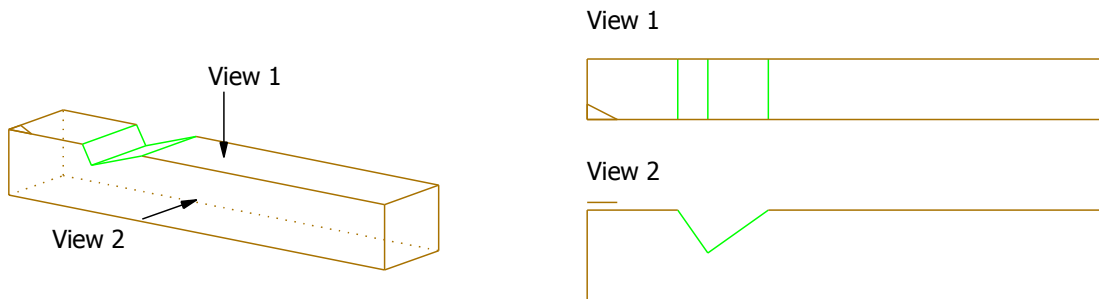

8. SCALEUNIT Position of the decimal point from the right in a "string 8 characters"
 The unit of metric parameters is millimeter and the unit of angles is degree.
 Example: If scaleunit=1 the precision is 1/10, if scaleunit=2 the precision is 1/100.
 Each Parameter with format "String 8 characters" is multiplied with a scaleunit factor, rounded and written to the btl-file.
 Example: If value of parameter P01 is 123.2345678mm and scaleunit is 2, then P01=00012323.
 And if scaleunit=1, then P01=00001232.
 It is same for parameters, which contain a flag, a bit or an integer value like P04 for Lap Joint.
 Example: If value of parameter P04 is 15 and scaleunit is 2, then P01=00001500.
 And if scaleunit=1, then P01=00000150.

9. Examples for values in the BTL file

Format		example	value
String max.256 characters	Text must be in quotes	LISTNAME: "Dach"	
Integer		SINGLEMEMBERNUMBER: 1 SCALEUNIT: 2	1 2
String 8 characters <i>In these examples, SCALEUNIT=2</i>	SCALEUNIT must be used	TRANSFORMATION: OX:00000000 OY:00056789 OZ:... HEIGHT: 00018000 PROCESSPARAMETERS: P01:00000000 P06:000-4500 P03:... PROCESSPARAMETERS: P01:00000000 P04:00000300 P03:...	OY=567,89mm H=180mm P06=-45 degrees P04=3

10. Part in a rawpart

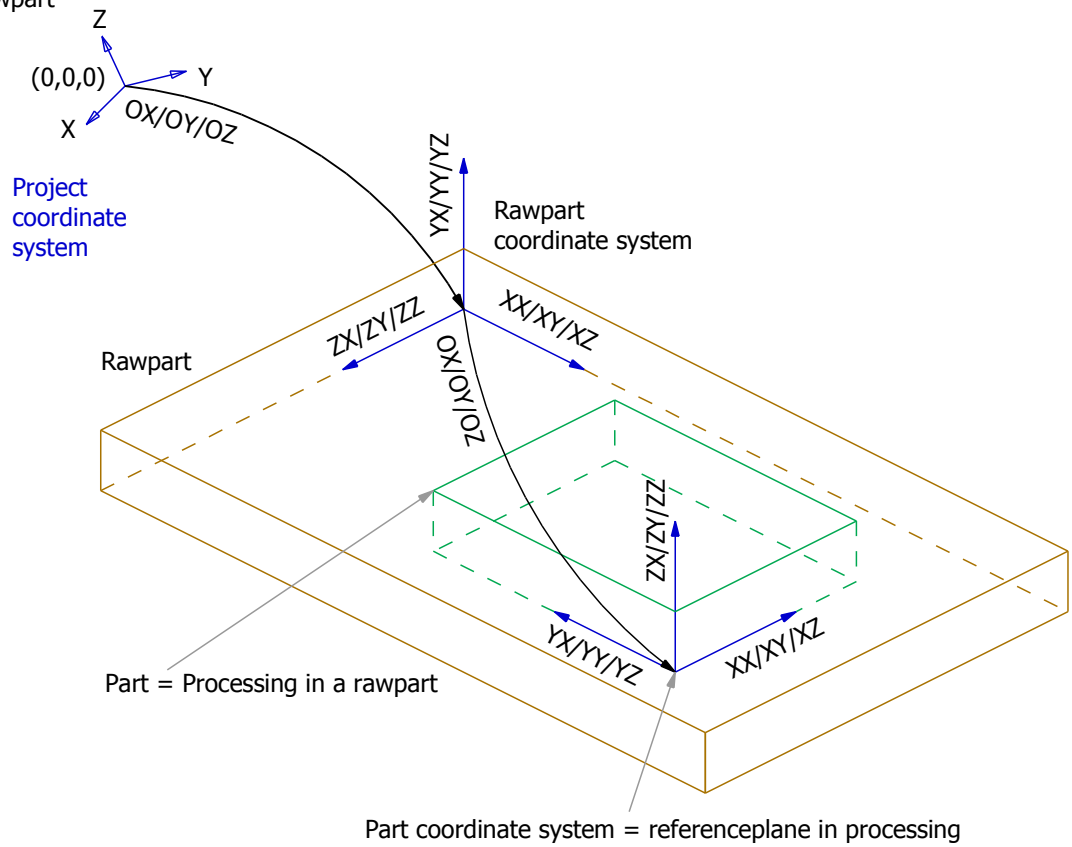

11. Camber

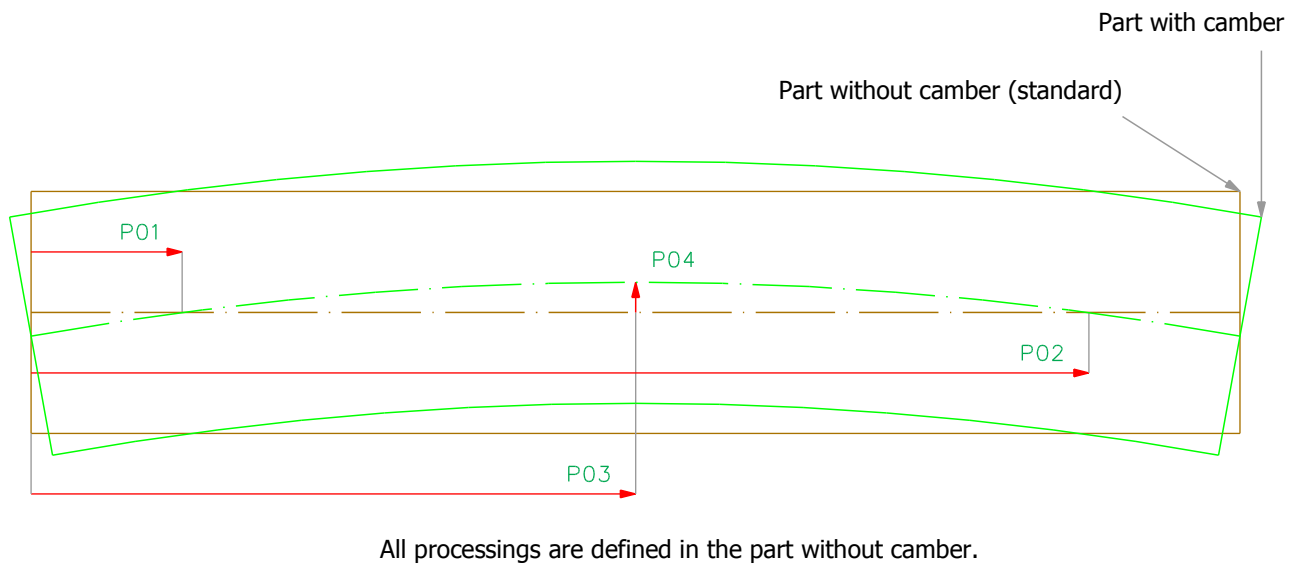

3. Example File

```
VERSION: "BTL V10.1"
BUILD:   "10100"
[GENERAL]
PROJECTNUMBER: "043"
PROJECTNAME:   "Company Warehouse"
PROJECTPART:   ""
LISTNAME:     "Roof"
CUSTOMER:     ""
ARCHITECT:    ""
EDITOR:      "Smith"
DELIVERYDATE: "2006-11-30"
EXPORTDATE:  "2006-09-26"
EXPORTTIME:  "09:20:11"
EXPORTRELEASE: "SEMA Holzbausoftware V10.2 (de) Build 10461"
LANGUAGE:    "DE"
SCALEUNIT:  1
COMPUTERNAME: "My Computer"
USER:       "Jones"
COMMENT:    "043"
COMMENT:    "010"
COMMENT:    "Company Warehouse"
COMMENT:    "Sussex"
COMMENT:    "Smith"
COMMENT:    "15"
COMMENT:    "J. Doe"
COMMENT:    ""
[PART]
SINGLEMEMBERNUMBER: 1
ASSEMBLYNUMBER:    ""
ORDERNUMBER:      1
DESIGNATION:      "Purlin"
ANNOTATION:       "B:1 Nr:1"
STOREY:          "DG1"
GROUP:           "01"
PACKAGE:         "1"
MATERIAL:        "Redwood"
TIMBERGRADE:     "BSH"
QUALITYGRADE:    "S10"
COUNT:          1
LENGTH:          00146700
HEIGHT:          00002400
WIDTH:           00001800
PLANINGLENGTH:    00022700
STARTOFFSET:     00000200
ENDOFFSET:       00000200
TRANSFORMATION:  OX:00000000 OY:00000000 OZ:00000000 XX:00010000 XY:00000000
                  XZ:00000000 YX:00000000 YY:00010000 YZ:00000000
PARTOFFSET:     P04:00000010 P11:00000000 P12:00000500 P13:00000000 P14:00000000
```

PROCESSKEY: 2-010-2 Saw Cut
PROCESSPARAMETERS: P01:00000000 P02:00000000 P03:00000000 P06:00000900 P07:00000900
PROCESSIDENT: 1
PROCESSKEY: 4-090-1 Planing
PROCESSPARAMETERS: P01:00000000 P04:00001240 P11:00000000 P12:00011350
PROCESSIDENT: 2
PROCESSKEY: 4-060-3 Marking
PROCESSPARAMETERS: P01:00131250 P06:00000900 P11:00000800 P13:00000010 P14:01310740
PROCESSIDENT: 3
PROCESSKEY: 4-090-1 Planing
PROCESSPARAMETERS: P01:00135350 P04:00001240 P11:00000000 P12:00011350
PROCESSIDENT: 4
PROCESSKEY: 1-010-2 Saw Cut
PROCESSPARAMETERS: P01:00146700 P02:00000000 P03:00000000 P06:00000900 P07:00000900
PROCESSIDENT: 5
[PART]
SINGLEMEMBERNUMBER: 2
ASSEMBLYNUMBER: ""
ORDERNUMBER: 2
DESIGNATION: "Rafler"
ANNOTATION: "B:1 Nr:1"
STOREY: "DG1"
GROUP: "01"
PACKAGE: "1"
MATERIAL: "Oak"
TIMBERGRADE: "KVH"
QUALITYGRADE: "S13"
COUNT: 1
LENGTH: 00067936
HEIGHT: 00001800
WIDTH: 00000800
PLANINGLENGTH: 00014610
STARTOFFSET: 00000200
ENDOFFSET: 00000200
TRANSFORMATION: OX:00000000 OY:00000000 OZ:00000000 XX:00010000 XY:00000000
XZ:00000000 YX:00000000 YY:00010000 YZ:00000000
PARTOFFSET: P04:00000010 P11:00000000 P12:00000500 P13:00000000 P14:00000000
PROCESSKEY: 2-011-2 Double Cut
PROCESSPARAMETERS: P02:00001260 P06:00000900 P07:00000900 P08:00000350 P09:00000900
PROCESSIDENT: 1
PROCESSKEY: 4-090-1 Planing
PROCESSPARAMETERS: P01:00000000 P04:00001240 P11:00000000 P12:00014611
PROCESSIDENT: 2
PROCESSKEY: 4-020-1 Birds Mouth
PROCESSPARAMETERS: P01:00021778 P06:00000900 P07:00000350 P08:00001250
P11:00000300 P12:00000300
PROCESSIDENT: 3
PROCESSKEY: 1-010-2 Saw Cut
PROCESSPARAMETERS: P01:00067936 P02:00000000 P03:00000000 P06:00000550 P07:00000900
PROCESSIDENT: 4

4. Table of Contents

1.1	Cut	1/2-010-X	1
1.2	Longitudinal Cut	0/3/4-010-X	3
1.3	Double Cut	1/2-011-X	5
1.4	Ridge or Valley Cut	0-012-X	7
1.5	Saw Cut	0/3/4-013-X	9
1.6	Slot	3/4-016-X	11
1.7	Front Slot	3/4-017-X	15
1.8	Birds Mouth	3/4-020-X	17
1.9	Ridge Lap	1/2-030-X	22
1.10	Lap Joint	3/4-030-X	25
1.11	Notch / Rabbet	3/4-032-X	28
1.12	Block House Half Lap, Stair Riser Dado	3/4-033-X	30
1.13	Seathing Cut	3/4-034-X	32
1.14	French Ridge Lap	1/2-035-X	34
1.15	Chamfer	3/4-036-X	36
1.16	Block House Half Lap	4-037-X	38
1.17	Block House Front	3/4-038-X	40
1.18	Pocket	4-039-X	42
1.19	Drilling	3/4-040-X	44
1.20	Tenon	1/2-050-X	46
1.21	Mortise	3/4-050-X	48
1.22	Mortise Front	3/4-051-X	50
1.23	House	3/4-052-X	52
1.24	House Mortise	3/4-053-X	54
1.25	Dovetail Tenon	1/2-055-X	56
1.26	Dovetail Mortise	3/4-055-X	58
1.27	Dovetail Mortise Front	3/4-056-X	60
1.28	Marking / Labeling	3/4-060-X	62
1.29	Simple Scarf	1/2-070-X	65
1.30	Scarf Joint	1/2-071-X	67
1.31	Step Joint	1/2-080-X	69
1.32	Step Joint Notch	3/4-080-X	71
1.33	Planing	3/4-090-X	73
1.34	Profile Front	3/4-100-X	75
1.35	Profile Head concave	3/4-101-X	77
1.36	Profile Head convex	3/4-102-X	79
1.37	Profile Head cambered	3/4-103-X	81
1.38	Round Arch	3/4-104-X	83
1.39	Triangle Cut	4-120-X	85
1.40	Dovetail	1/2/3/4-138-X	87
1.41	Free Contour	0/3/4-250-X	90
1.42	Variant	0/1/2/3/4-900-X	92

5. History

Date	Modification	Build	Page
24.10.2006	Description of P03 for Lap Joint.	10000	25
	Description of P03 for Saw Cut.	10000	9
	Description of P08 - P15 for Block House Half Lap.	10000	38
25.10.2006	P07 for Step Joint and Step Joint Notch can be more than 90	10000	65, 67
05.12.2006	Free Contour added. 0/3/4-250-X	10001	81
05.12.2006	Referenceplane	10001	III, IV
13.12.2006	Correction of Description of P14: "P14" instead of "P13"	10001	27
13.12.2006	Description of P04 for Notch/Rabbit	10001	29
06.04.2007	Added quality for project, part and construction form	10100	II, III
	Added rawpart	10100	III
	Added camber	10100	IV
	Description of the referenceplane in a PROCESSING	10100	VII
	Recess: complete / manual processing	10100	V
	Priority	10100	VI
	Added colour for part	10100	IV
23.04.2007	Added processing HOUSE	10100	52
	Added processing HOUSE MORTISE	10100	54
	Added rounding to tenon	10100	46
	Added rounding to mortise	10100	48
	Added chamfer to tenon	10100	46
	Added processing VARIANT	10100	87
	Added OUTLINE to the part	10100	V
02.07.2007	Added COMMENT to the processing	10100	VI
	Changed Typ A at Step Joint 1/2-080-X	10100	69, 71
	The Pocket 4-039-X is only defined for group 4.	10100	42
	Alignment of the text at Marking/Labeling 3/4-060-X.	10100	63
	The Profile head cambered is defined with a cubic polynom.	10100	81
	Defined the position of the opposite lap at Block house half lap 4-037-X	10100	38
	Definition of the radius at the tenon with rounding, P04=3	10100	47
12.09.2007	New Limits of angle P06 drilling: 0/360	10100	45
20.10.2007	The meaning of STOREY and ANNOTATION was corrected	10100	IV
01.11.2007	Added Triangle Cut	10200	85
	Added Dovetail	10200	87
13.11.2007	Added RECESS to part and processing	10200	II, VI
	Added rafter nail to Birds Mouth	10200	21
	Specify the angle P10 at Lap Joint	10200	25, 26
25.11.2007	Description for P04="automatic" at Tenon 1/2-050-X	10200	47
10.12.2007	New presentation of the drilling parameters	10200	44
24.01.2008	Contour: Depth only relevant at startpoint	10200	91
31.01.2008	Depth at Longitudinal Cut 0/3/4-010-X	10200	4
21.04.2008	Birds Mouth 3/4-020-X: P14/P15 are orthogonal on face.	10200	18, 19
07.05.2008	Mortise 3/4-050-X: Added P16 in the parameter list.	10200	49
30.05.2008	Block House Front: Limit of P11, P12, P13.	10200	41
20.12.2008	Corrected the names of the coordinate system.	10200	VII, IX
26.12.2008	Additional description for Slot.	10200	13
	Additional description for Marking / Labeling	10200	64
28.01.2009	New description for P11 for Longitudinal Cut 0/3/4-010-X	10200	4
	Additional description for Slot.	10200	13
24.02.2009	New presentation of the Step Joint Notch parameters	10200	71, 72
13.05.2009	Description P03 for Drilling: P03 <> 0 instead of P03 > 0	10200	45
14.05.2009	Contour: New description for a contour with an associating contour	10200	91, 92

1.1 Cut 1-010-X and 2-010-X

2-010-X

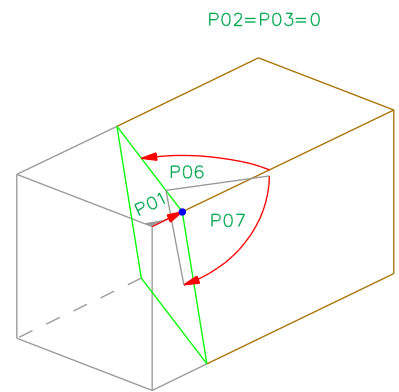
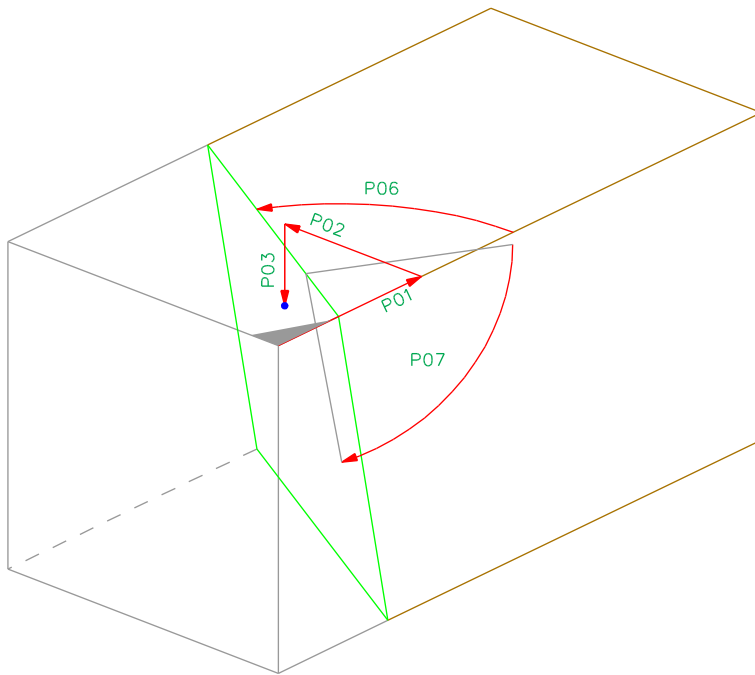

1-010-X

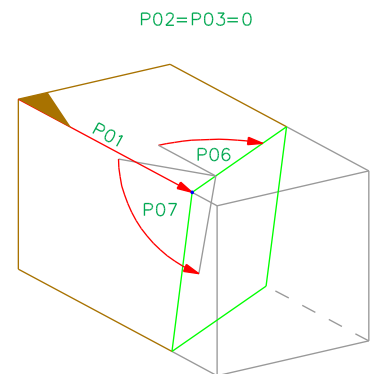
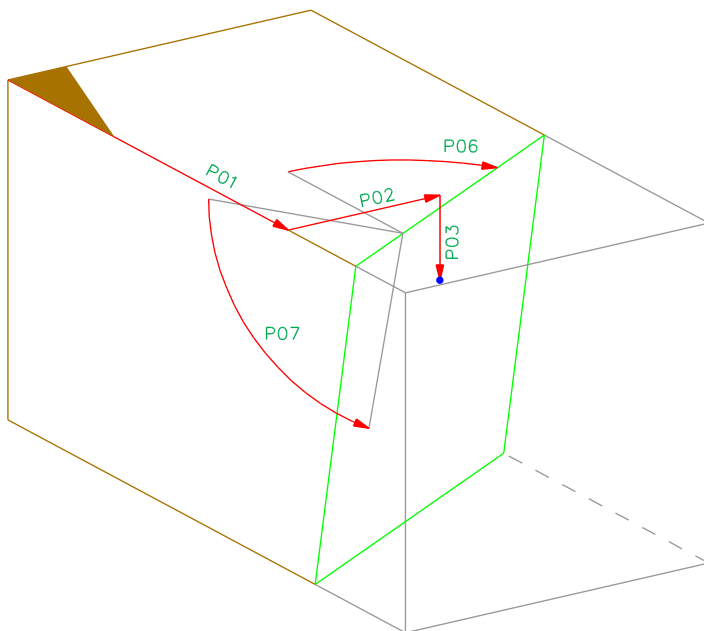

1.1 Parameters Cut

1-010-X and 2-010-X

Parameter	Min/Max	Presetting	Description
P01	+/- 99999	0	Distance from beam start to the reference point
P02	0/50000	0	Distance from the reference edge to the reference point
P03	0/50000	0	Distance from the reference side to the reference point (orthogonal)
P06	1/179	90	Angle between cut edge and reference edge
P07	1/179	90	Inclination between face and reference side

1.2 Longitudinal Cut 0-010-X / 3-010-X / 4-010-X

P07 > 0

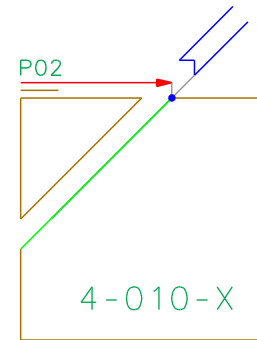
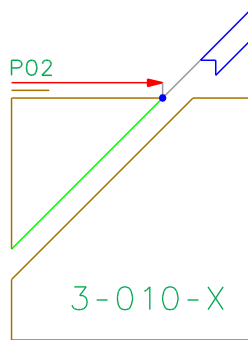
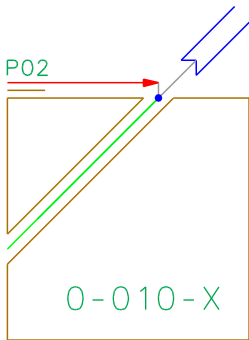
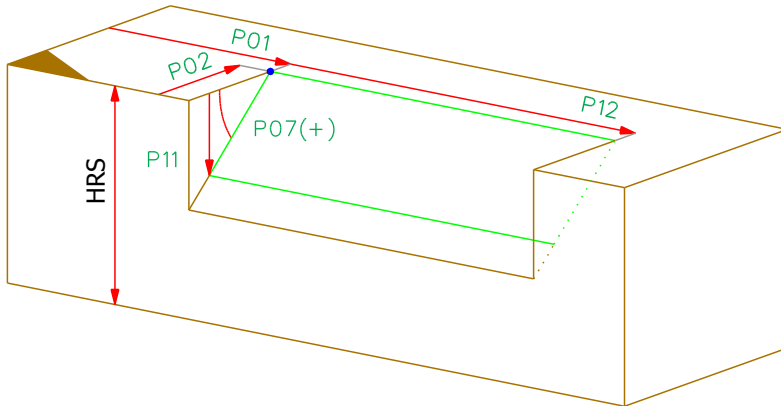

P07 < 0

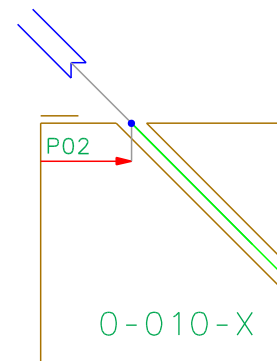
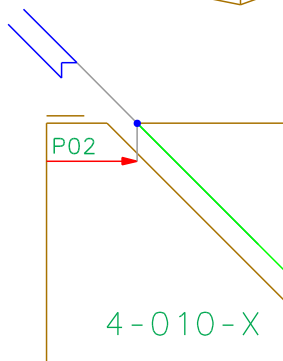
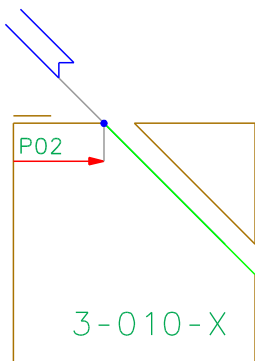
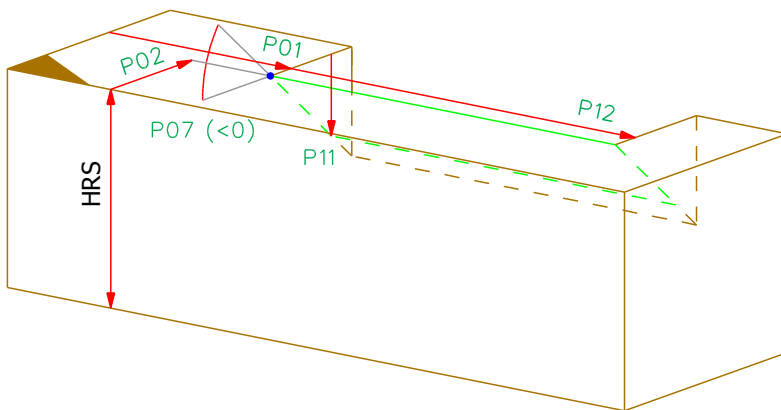

1.2 Parameters Longitudinal Cut

0-010-X / 3-010-X / 4-010-X

Parameter	Min/Max	Presetting	Description
P01	+/- 99999	0	Distance from beam start to the reference point
P02	+/- 50000	20	Distance from the reference edge to the reference point
P07	-90/90	45	Inclination to the reference side
P11	0/50000	0	Depth If P11 is zero, then its value must be calculated: $P11 = \text{MIN}(P02 \times \tan(P07), \text{HRS})$
P12	0/99999	0	Length If P12 equal to zero, the processing is performed along the whole component length

Position of the tool:

- Group 0: Saw guide in the middle
- Group 3: Saw guide opposite the reference edge
- Group 4: Saw guide towards the reference edge

1.3 Double Cut 1-011-X and 2-011-X

2-011-X

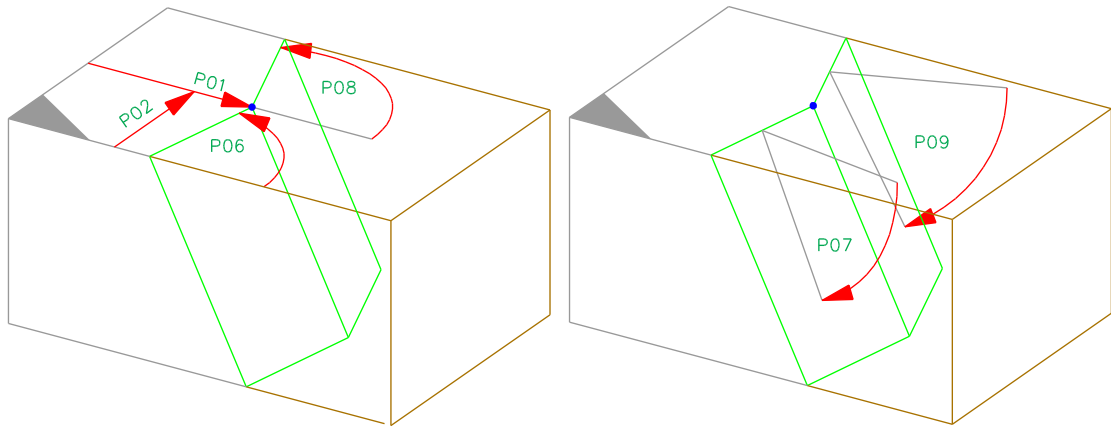

1-011-X

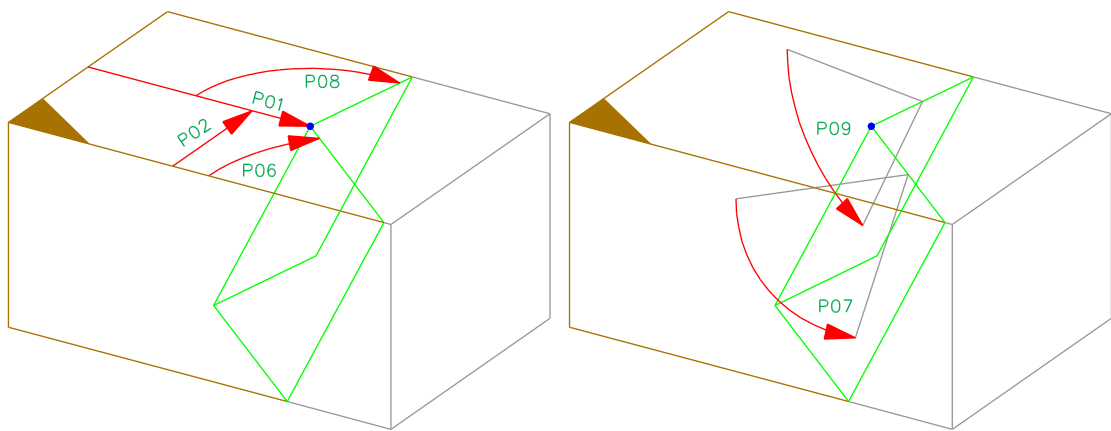

1.3 Parameters Double Cut

1-011-X and 2-011-X

Parameter	Min/Max	Presetting	Description
P01	+/- 99999	0	Distance from beam start to the reference point
P02	0/50000	50	Distance from the reference point to the reference edge
P06	1/179	45	Angle between the first cutting edge and the reference edge
P07	1/179	90	Inclination of the first cutting towards the reference side
P08	1/179	90	Angle between the second cutting edge and the reference edge
P09	1/179	90	Inclination of the second cutting towards the reference side

1.4 Ridge or Valley Cut 0-012-X

0-012-X

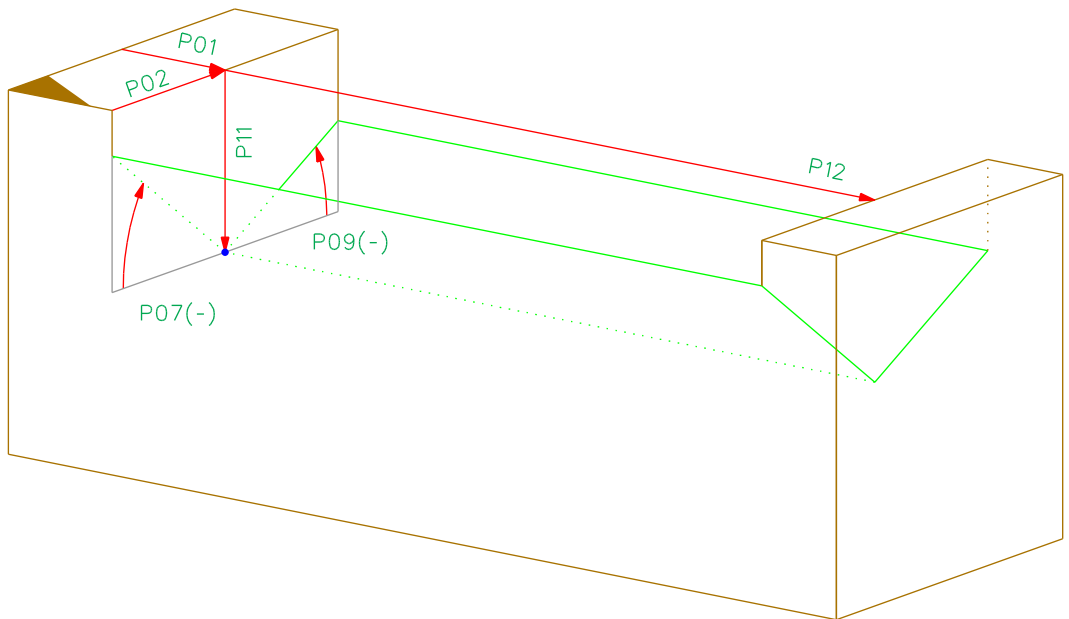
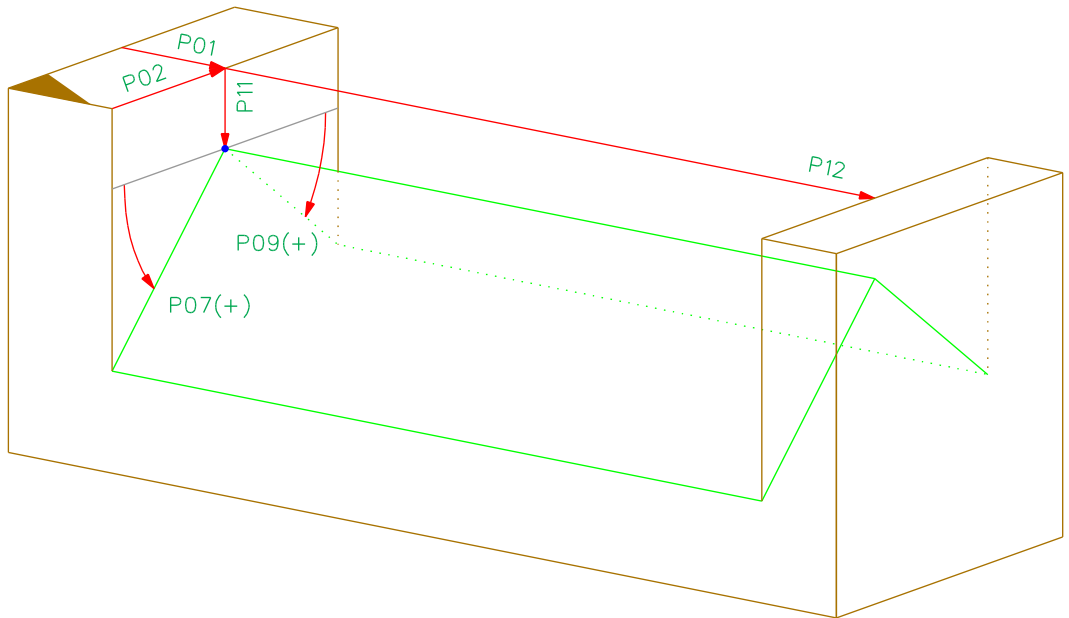

1.4 Parameters Ridge or Valley Cut

0-012-X

Parameter	Min/Max	Presetting	Description
P01	+/- 99999	0	Distance from beam start to the reference point
P02	0/50000	WRS/2	Distance from the reference point to the reference edge
P07	-89/89	45	Inclination between the first face and the reference side
P09	-89/89	45	Inclination between the second face and the reference side
P11	0/50000	0	Depth
P12	0/99999	0	Length If P12 equal to zero, the processing is performed along the whole component length

1.5 Saw Cut 0-013-X / 3-013-X / 4-013-X

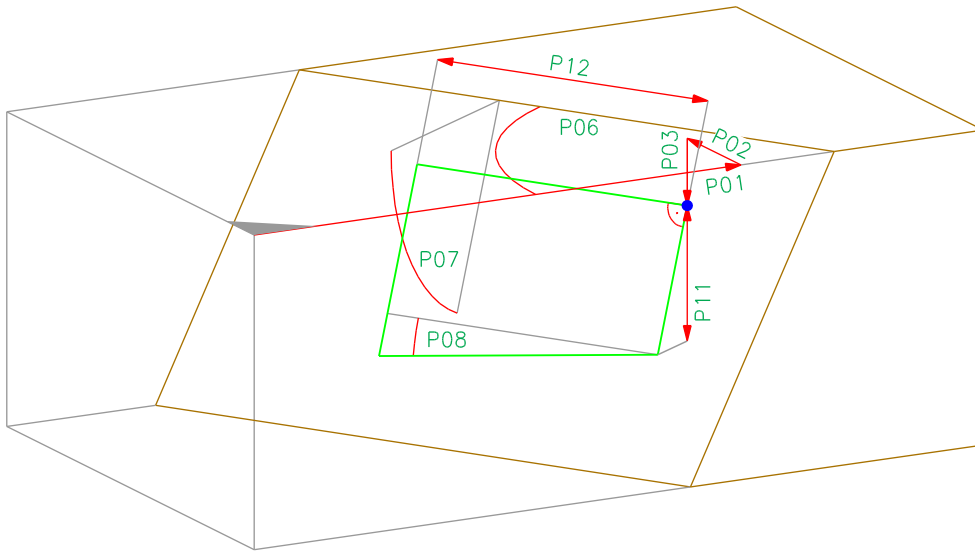

4-013-X

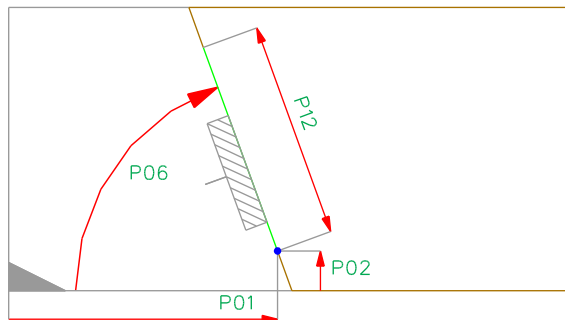

3-013-X

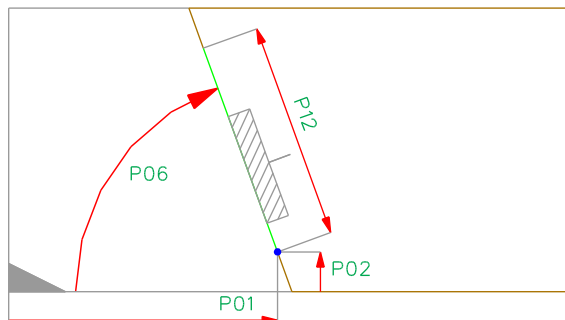

0-013-X

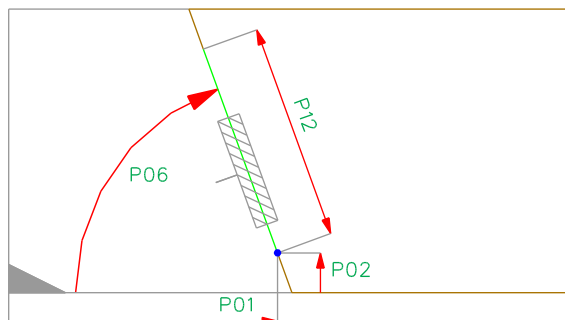

1.5 Parameters Saw Cut

0-013-X / 3-013-X / 4-013-X

Parameter	Min/Max	Presetting	Description
P01	+/- 99999	0	Distance from beam start to the reference point
P02	0/50000	0	Distance from the reference point to the reference edge
P03	0/50000	0	Displacement to the reference side
P06	0/180	90	Angle between cut edge and reference edge
P07	0/180	90	Inclination to the reference side
P08	-45/45	0	Angle to the reference edge in the cut face
P11	0/50000	HRS/2	Depth, orthogonal to the reference side
P12	0/99999	WRS	Length

1.6 Slot 3-016-X and 4-016-X

P03 = 0

4-016-X

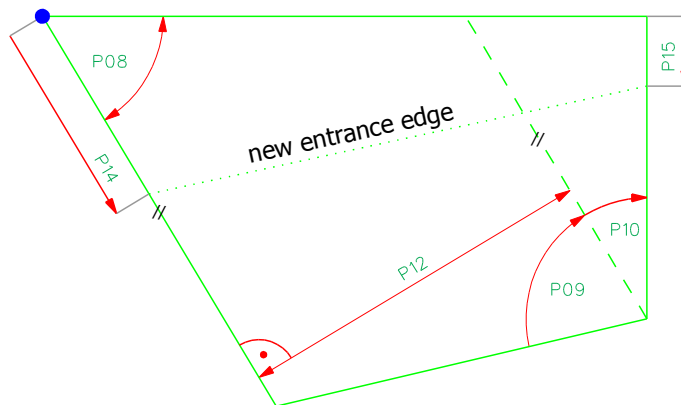
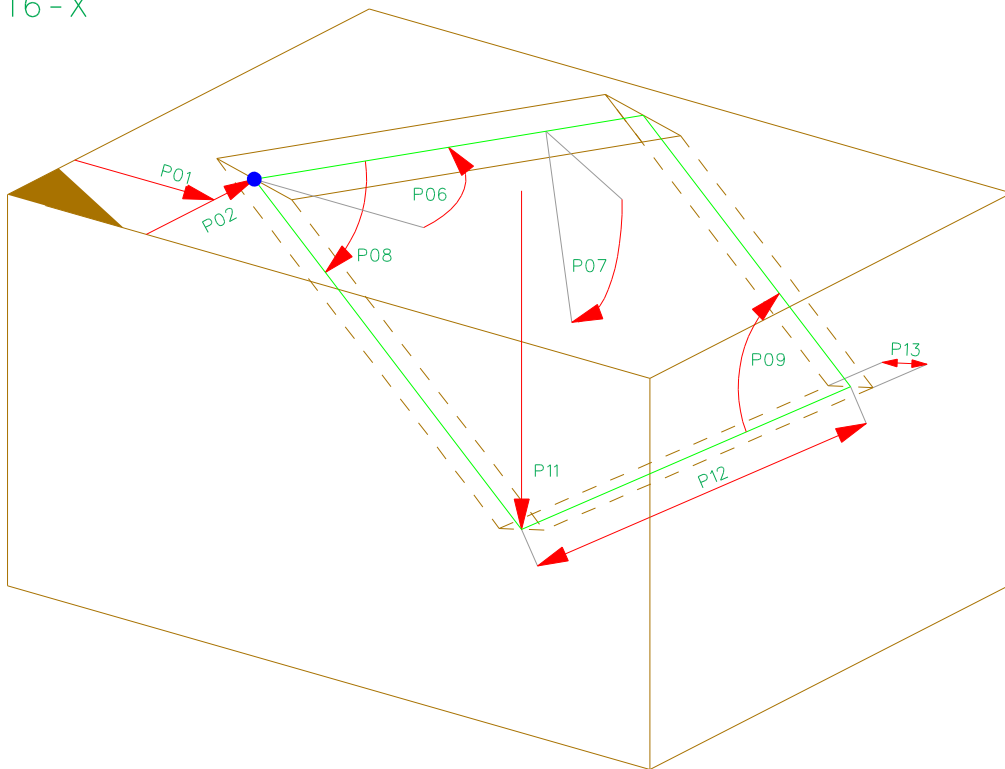

P03 = 0

4-016-X

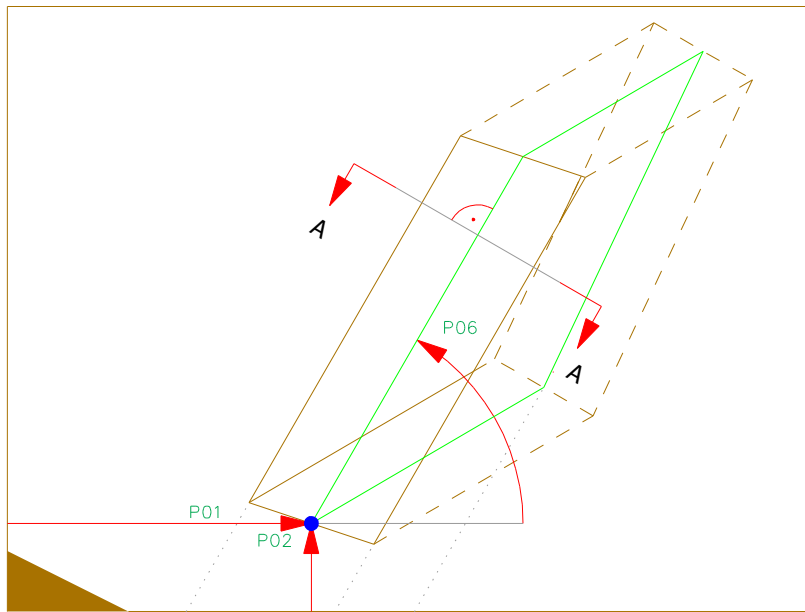

A - A

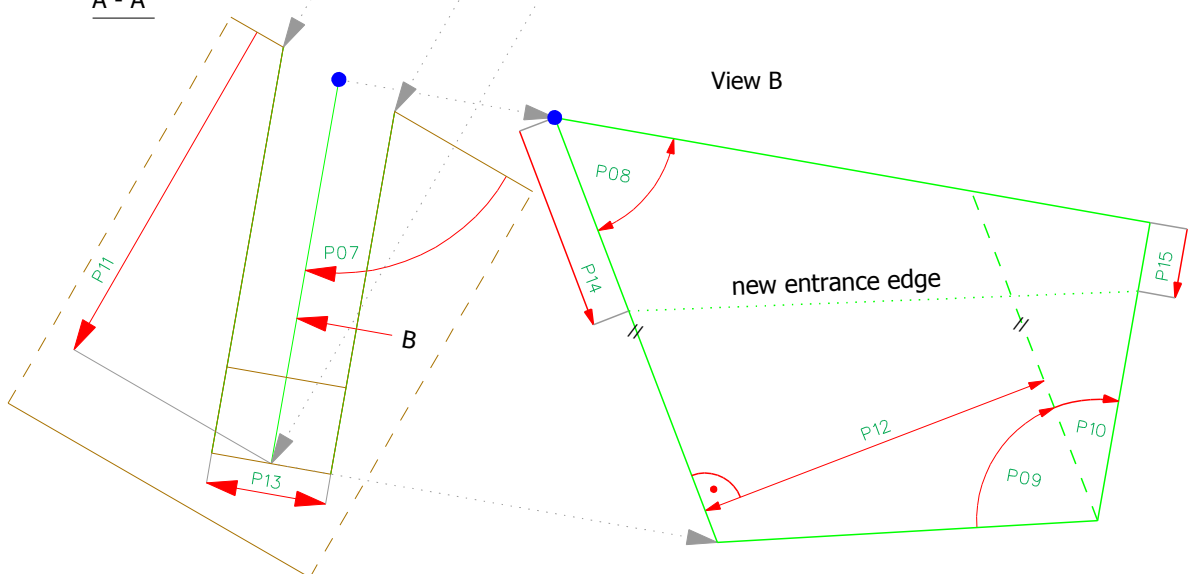

P03 > 0

4-016-X

3-016-X

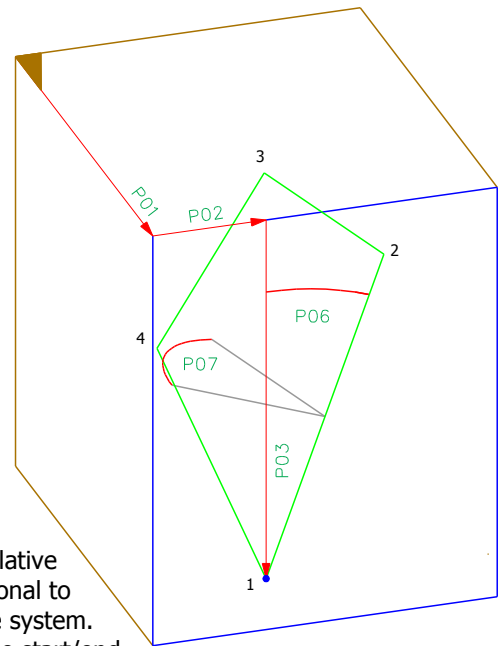
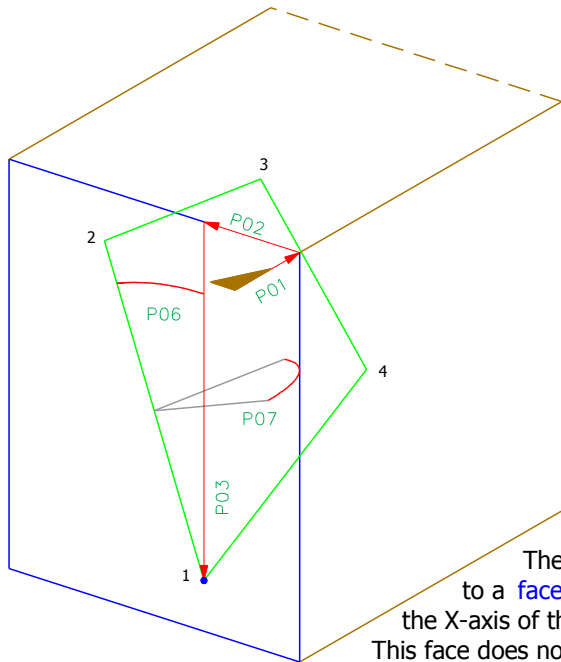

The slot is defined relative to a **face**, which is orthogonal to the X-axis of the part coordinate system. This face does not have to be at the start/end of the beam.

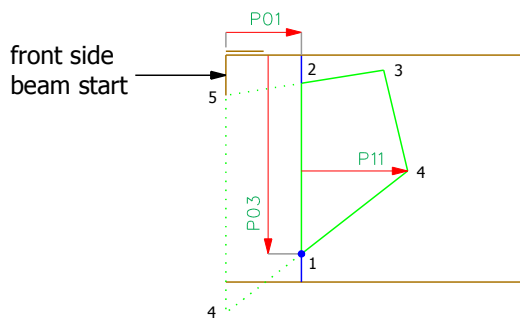

The slot is not limited towards the front sides when P03>0.

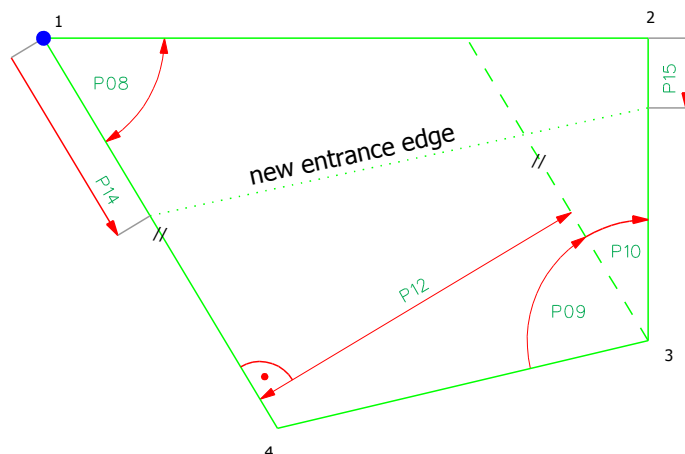
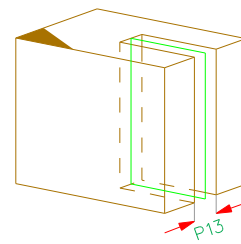
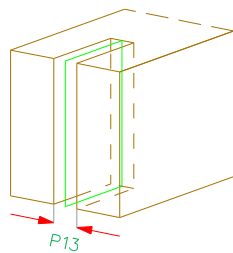
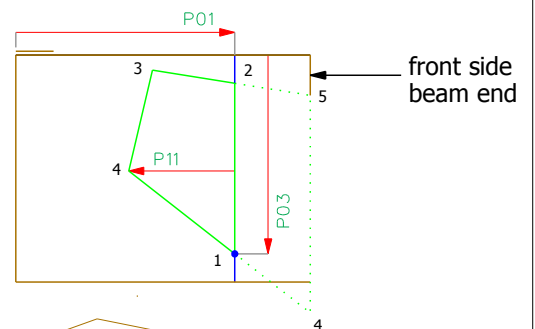

1.6 Parameters Slot

3-016-X and 4-016-X

Parameter	Min/Max	Presetting	Description
P01	+/- 99999	0	Distance from beam start to the reference point
P02	0/WRS	0	Distance from the reference edge to the reference point
P03	0/50000	0	Distance to the reference point orthogonal to the reference side P03 = 0: Slot on one of the 4 sides of the component. P03 > 0: Slot on one of the 2 front sides of the component
P06	-90/90	0	Angle to the reference edge in the reference side
P07	1/180	90	Inclination to the reference side
P08	1/179	90	Interior angle at reference point
P09	1/179	90	Interior angle at opposite of reference point
P10	1/179	0	Addition to P09
P11	1/50000	100	Depth orthogonal to the reference side
P12	1/99999	200	Length
P13	1/50000	10	Thickness
P14	0/50000	0	Displacement of the entrance edge at reference point
P15	0/50000	0	Displacement of the entrance edge at opposite of reference point

1.7 Front Slot 3-017-X and 4-017-X

4-017-X

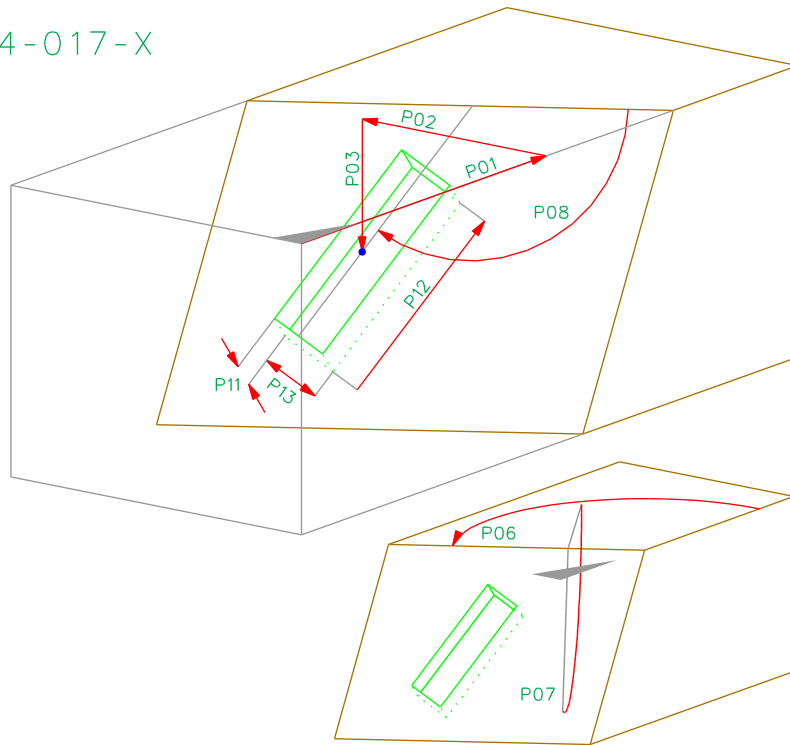

3-017-X

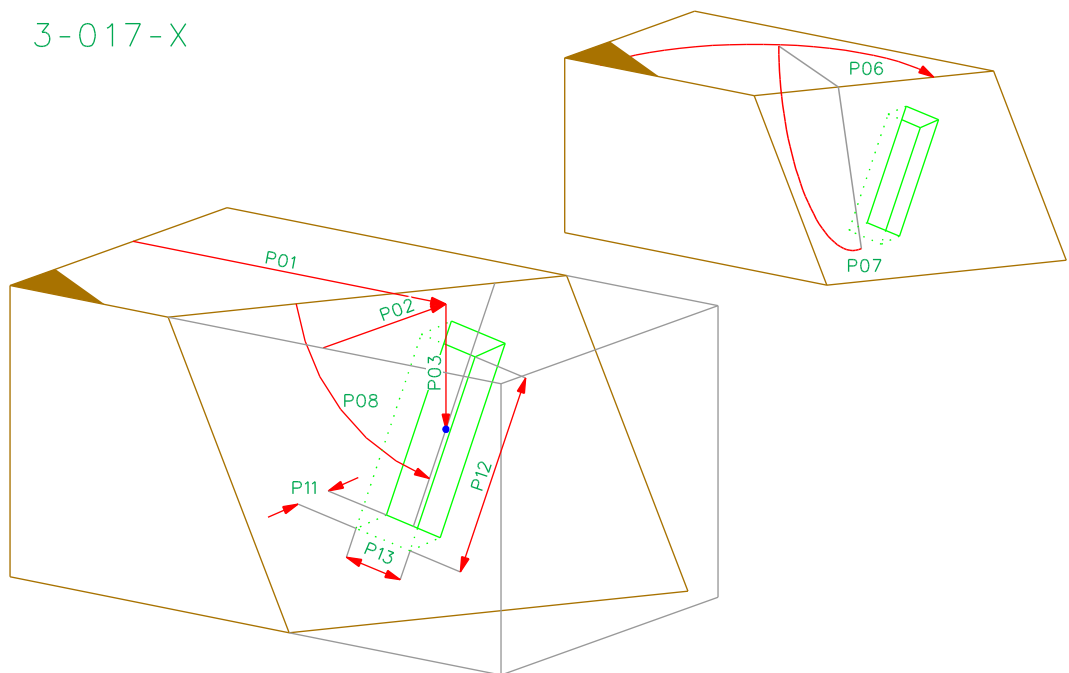

1.7 Parameters Front Slot

3-017-X and 4-017-X

Parameter	Min/Max	Presetting	Description
P01	+/- 99999	0	Distance from beam start to the reference point
P02	0/50000	0	Distance from the reference point to the reference edge
P03	0/50000	0	Distance to the reference point orthogonal to the reference side
P06	1/179	90	Angle between cut edge and reference edge
P07	1/179	90	Inclination to the reference side
P08	1/359	90	Angle between the longitudinal axis of the slot and the reference side
P11	0/50000	20	Depth
P12	0/50000	40	Length
P13	0/50000	40	Width

1.8 Birds Mouth 3-020-X and 4020-X

4-020-X

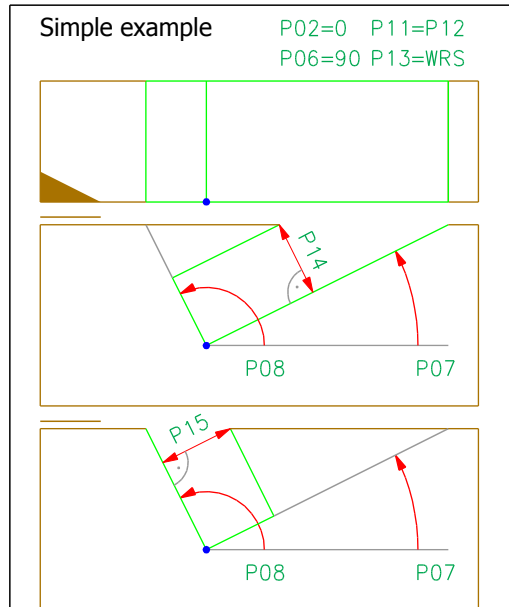
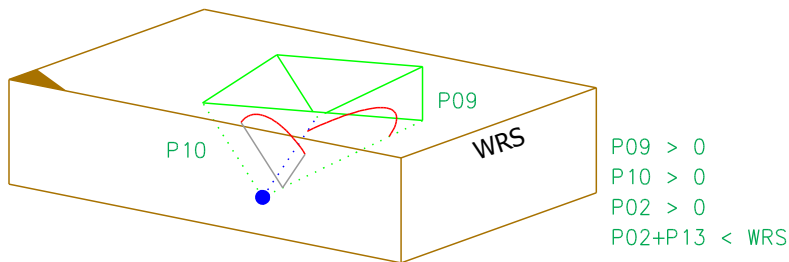
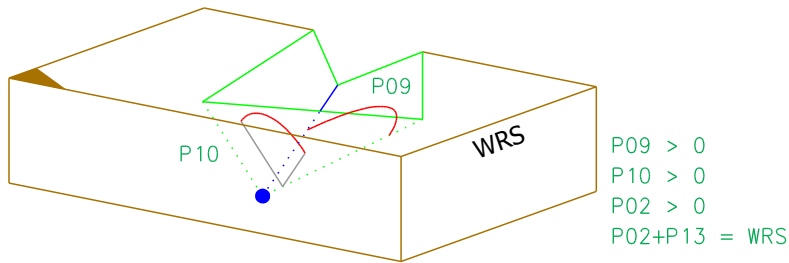
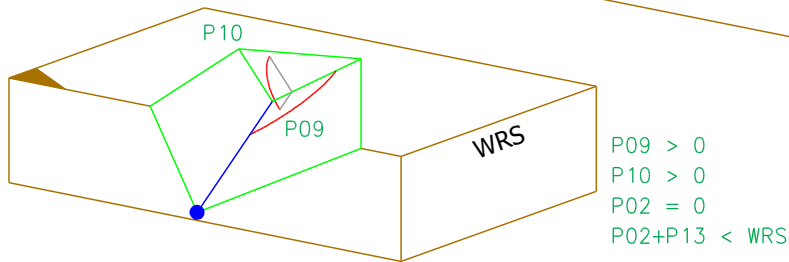
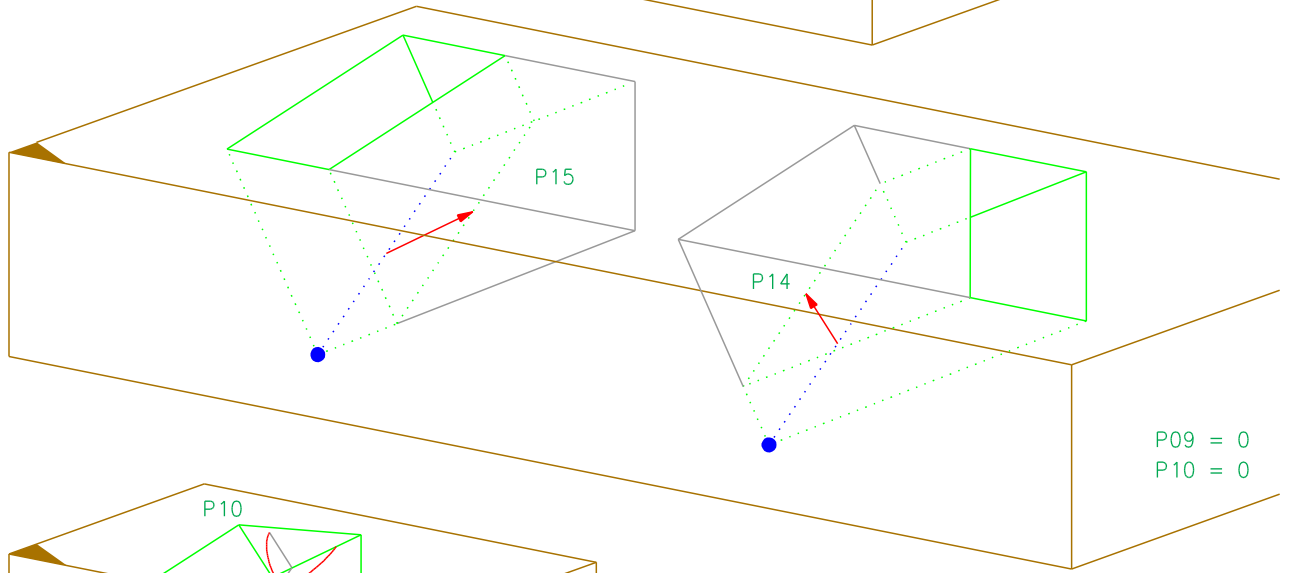
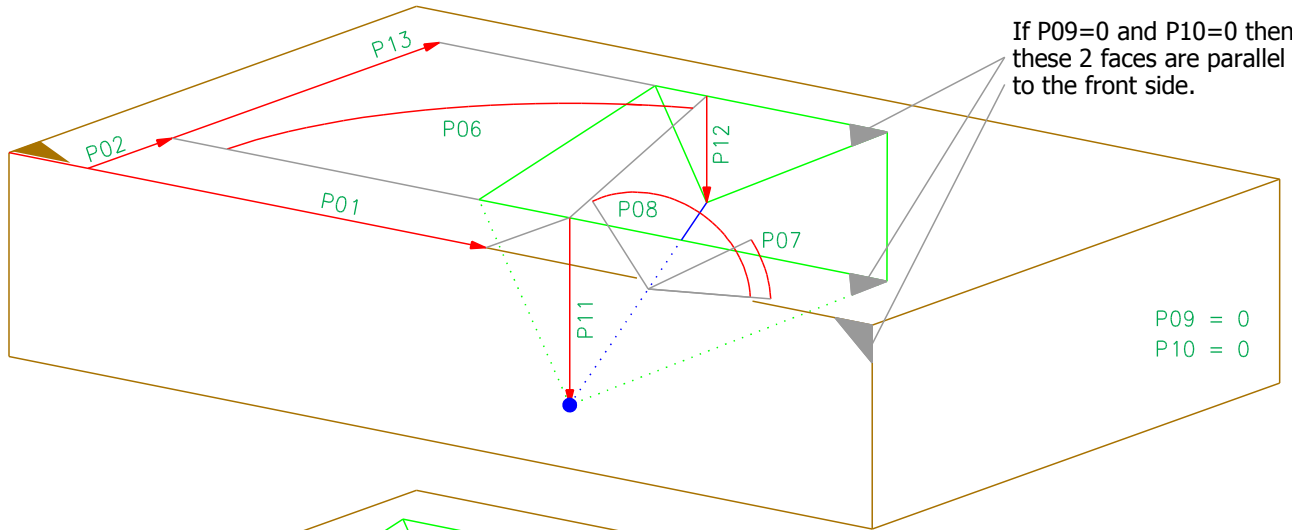

3-020-X

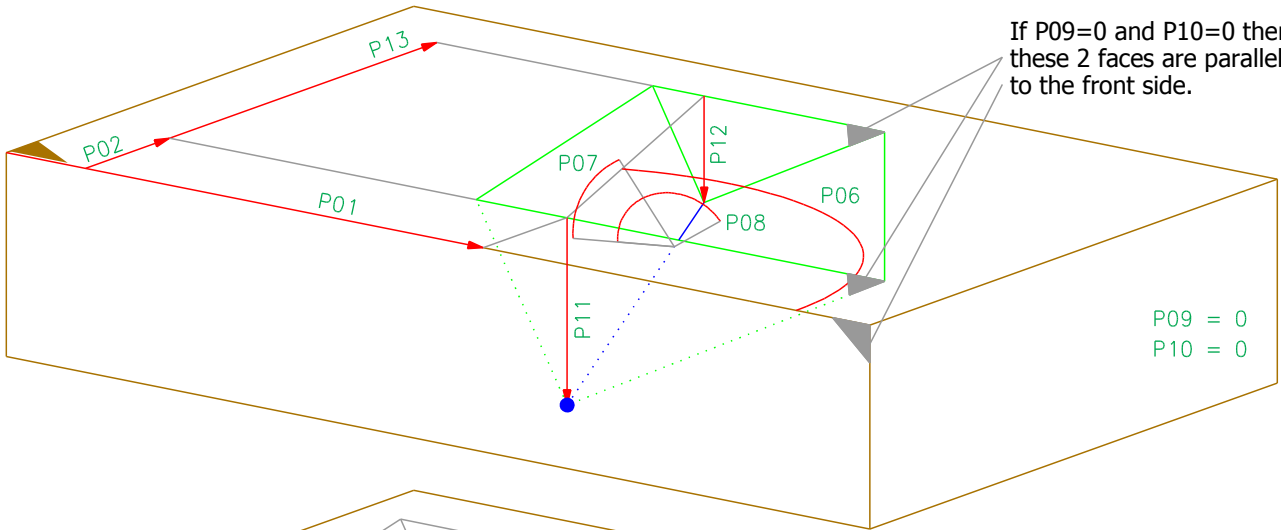

If $P09=0$ and $P10=0$ then these 2 faces are parallel to the front side.

$P09 = 0$
 $P10 = 0$

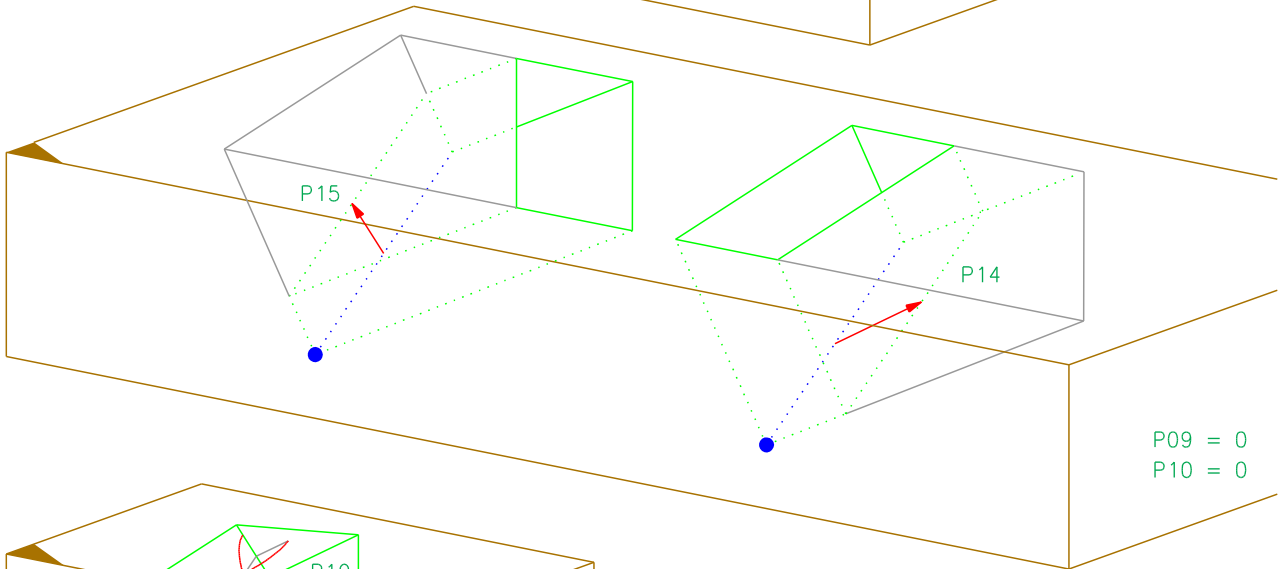

$P09 = 0$
 $P10 = 0$

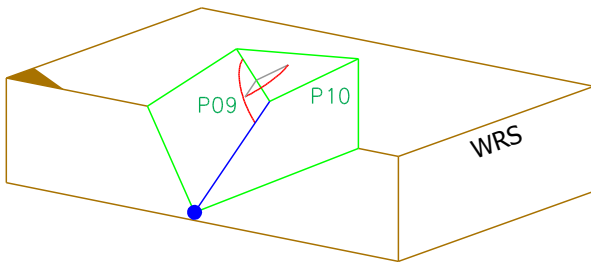

$P09 > 0$
 $P10 > 0$
 $P02 = 0$
 $P02+P13 < WRS$

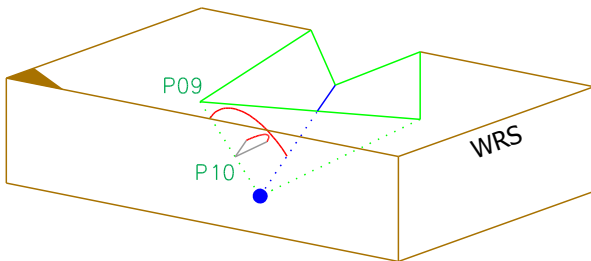

$P09 > 0$
 $P10 > 0$
 $P02 > 0$
 $P02+P13 = WRS$

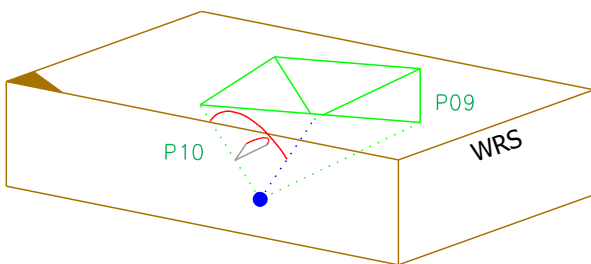

$P09 > 0$
 $P10 > 0$
 $P02 > 0$
 $P02+P13 < WRS$

Simple example $P02=0$ $P11=P12$
 $P06=90$ $P13=WRS$

3-020-X

Another presentation of parameters P07, P08

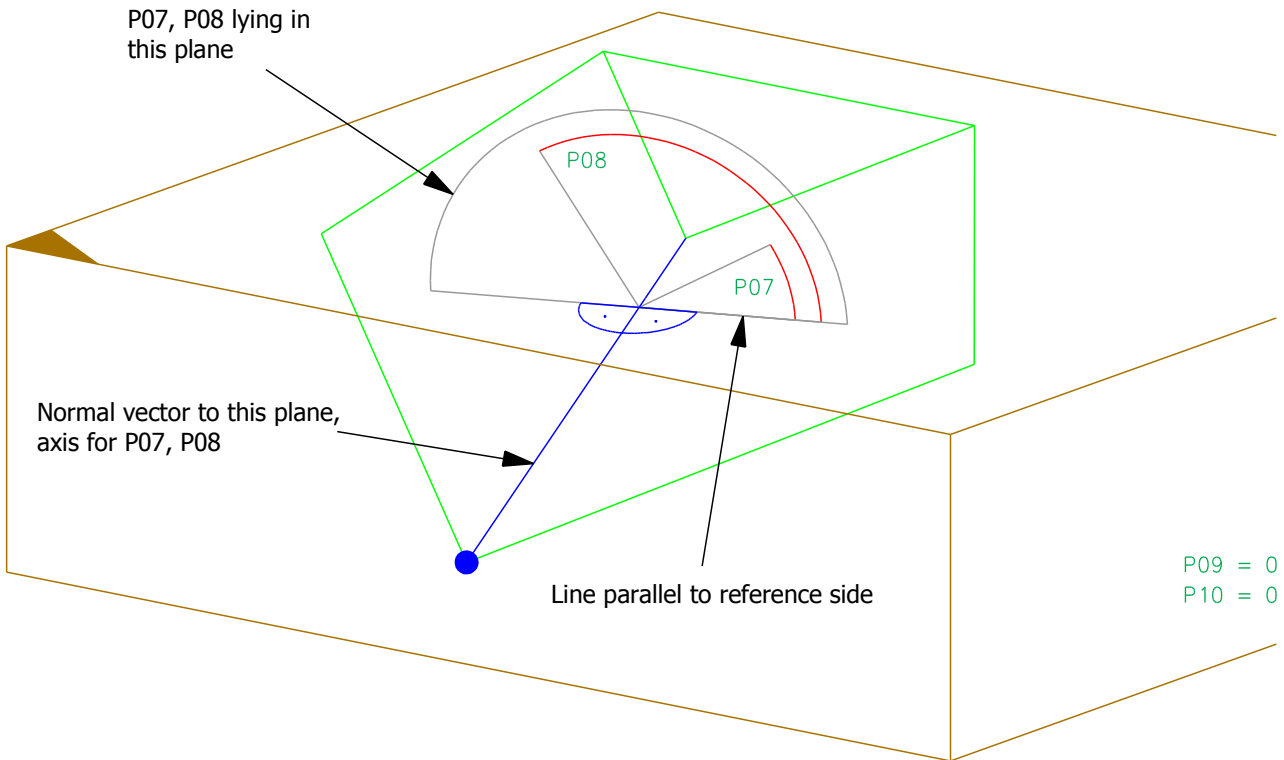

3-020-X

Another presentation of parameters P07, P08

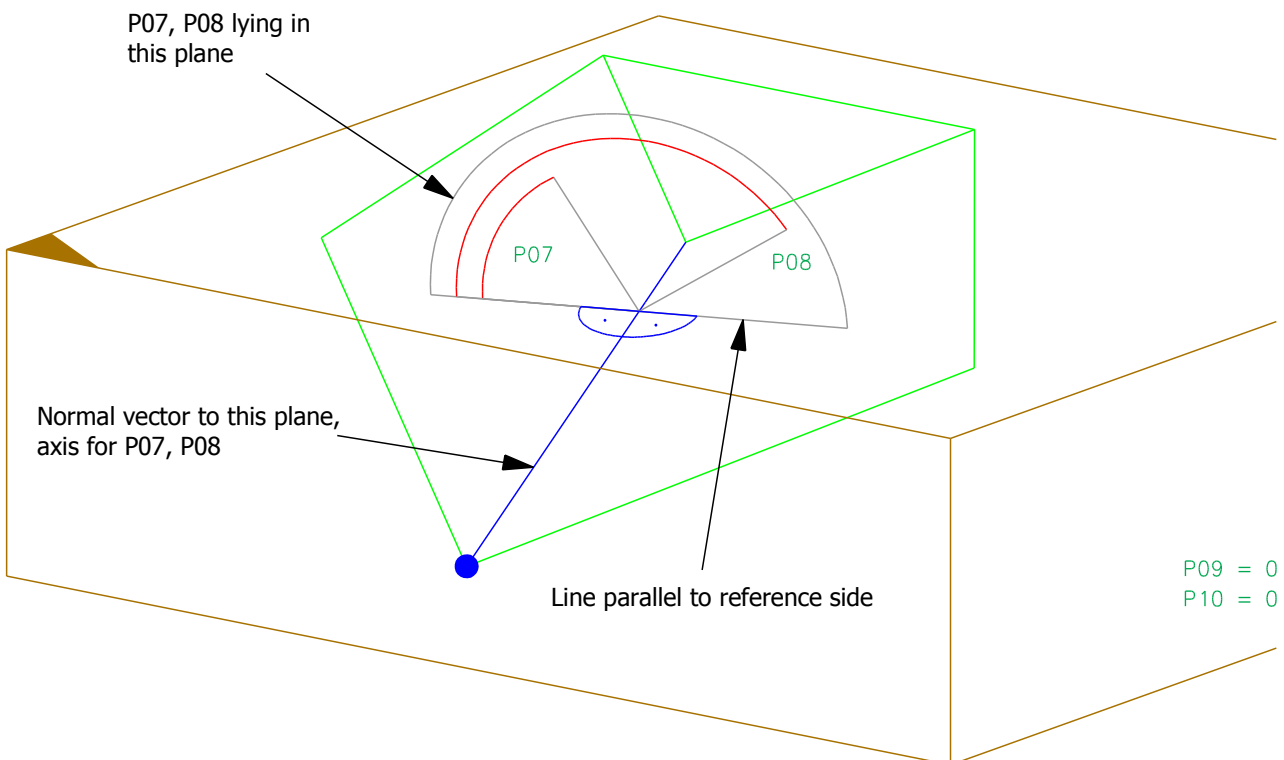

4-020-X $P_{09} > 0$ Another presentation of parameters

View orthogonal to face "P07"

The counterpart enters at the reference edge.

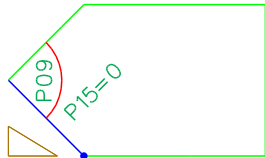

The counterpart enters at opposite of the reference edge.

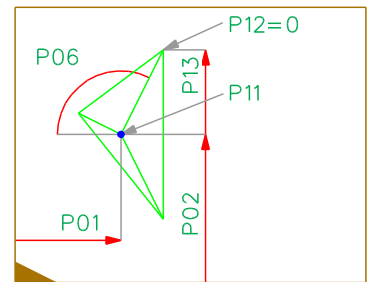
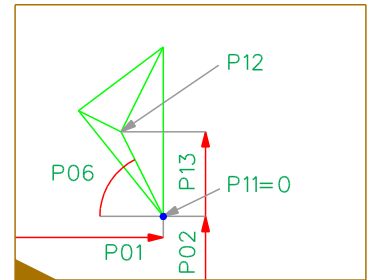
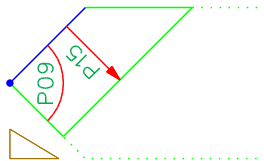
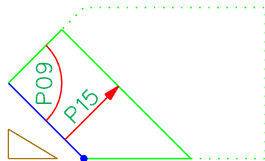
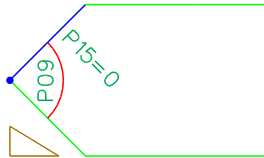

3-020-X $P_{09} > 0$ Another presentation of parameters

View orthogonal to face "P07"

The counterpart enters at the reference edge.

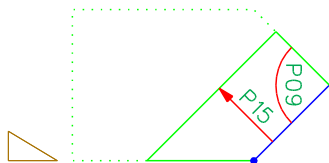

The counterpart enters at opposite of the reference edge.

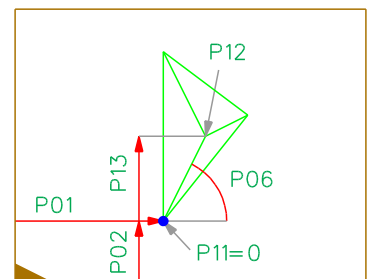
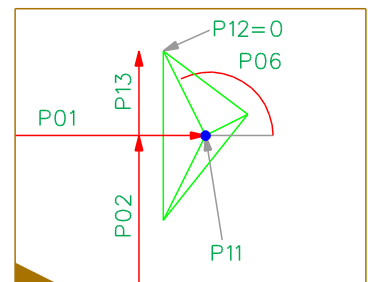
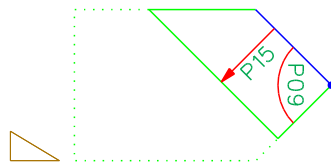

1.8 Parameters Birds Mouth

3-020-X and 4-020-X

Parameter	Min/Max	Presetting	Description
P01	+/- 99999	0	Distance from beam start to the reference point
P02	+/- 50000	0	Distance from the reference edge to the reference point
P05	0/1	0	P05=1: drillhole for rafter nail, P05=0: no drillhole The machineside defines place and direction of the drillhole.
P06	1/179	90	Angle to the reference edge in the reference area
P07	1/179	45	Inclination between face 1 and reference side
P08	1/179	135	Inclination between face 2 and reference side
P09	0/179	0	First cut angle of the counterpart If P09 is zero, the limit face beside face 1 is parallel to component side.
P10	0/179	0	First cut inclination of the counterpart If P10 is zero, the limit face beside face 1 is parallel to component side.
P11	0/50000	20	Depth 1 orthogonal to reference side
P12	0/50000	20	Depth 2 orthogonal to reference side
P13	0/50000	0	Grooving depth in the transverse direction of the component If P13 is zero, then its value must be calculated: $P13=WRS-P02$
P14	0/50000	0	Height Counterpart. Zero means: no limit. Measurement orthogonal to face 1 (P07).
P15	0/50000	0	Width Counterpart. Zero means: no limit. Measurement orthogonal to face 2 (P08).

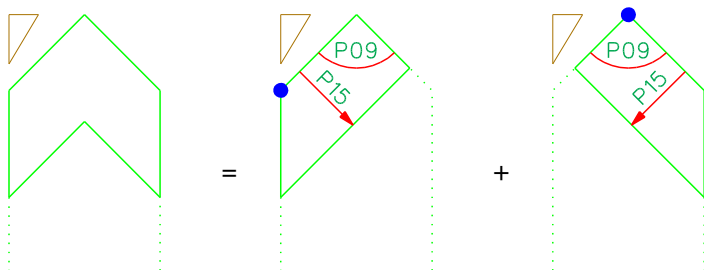

This kind of notch must be described with two notches.

1.9 Ridge Lap 1-030-X und 2-030-x

2-030-X
P02 = 0

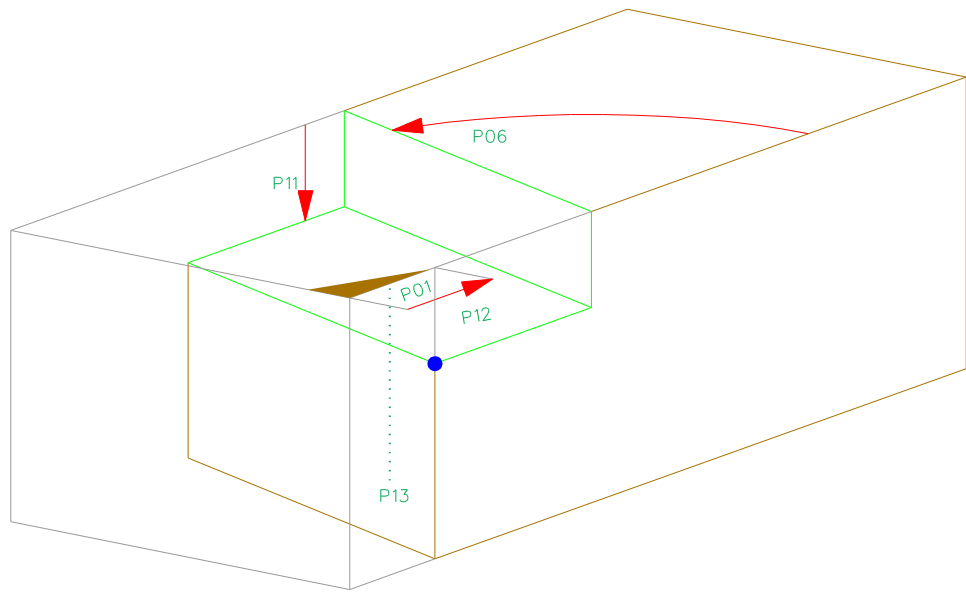

1-030-X
P02 = 0

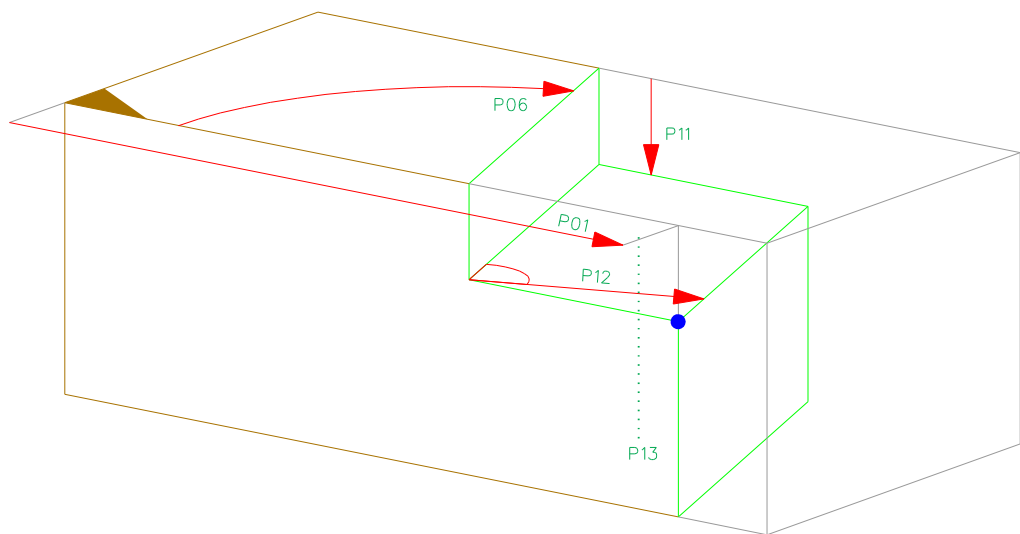

2-030-X
P02 = 1

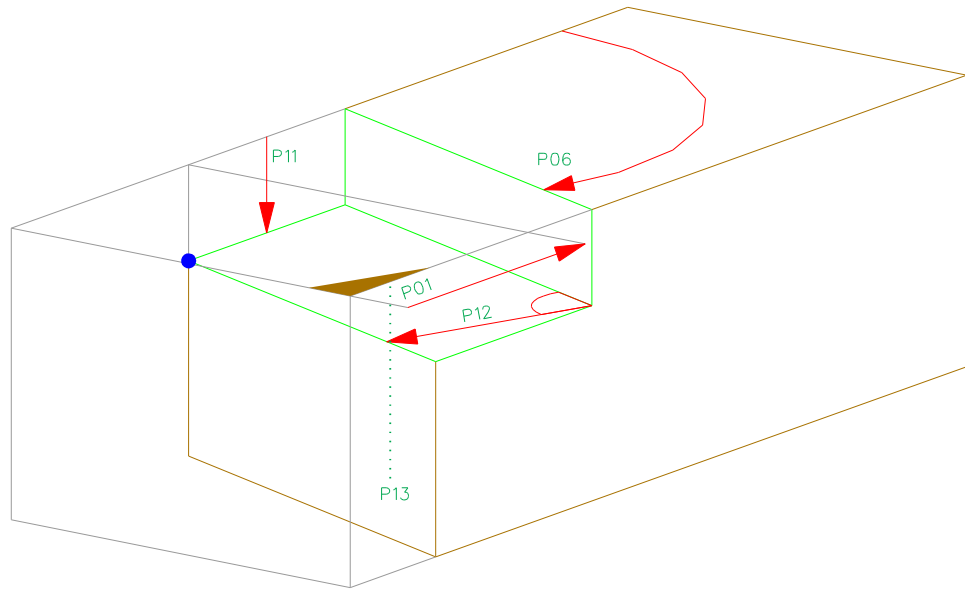

1-030-X
P02 = 1

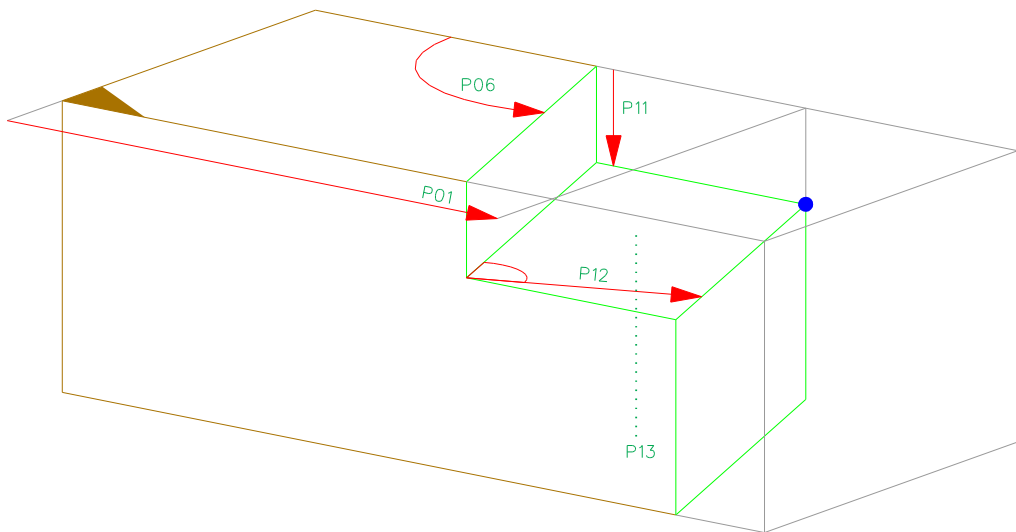

1.9 Parameters Ridge Lap

1-030-X and 2-030-X

Parameter	Min/Max	Presetting	Description
P01	+/- 99999	0	Distance from beam start to the reference point
P02	0/1	0	0: Reference point on referene edge 1: Reference point on the opposite edge
P06	1/179	90	Angle to the reference edge in the reference side
P11	1/50000	HRS/2	Depth of Half Lap
P12	1/50000	100	Width of Half Lap
P13	0/1000	0	Drill hole diameter

1.10 Lap Joint 3-030-X and 4-030-X

4-030-X

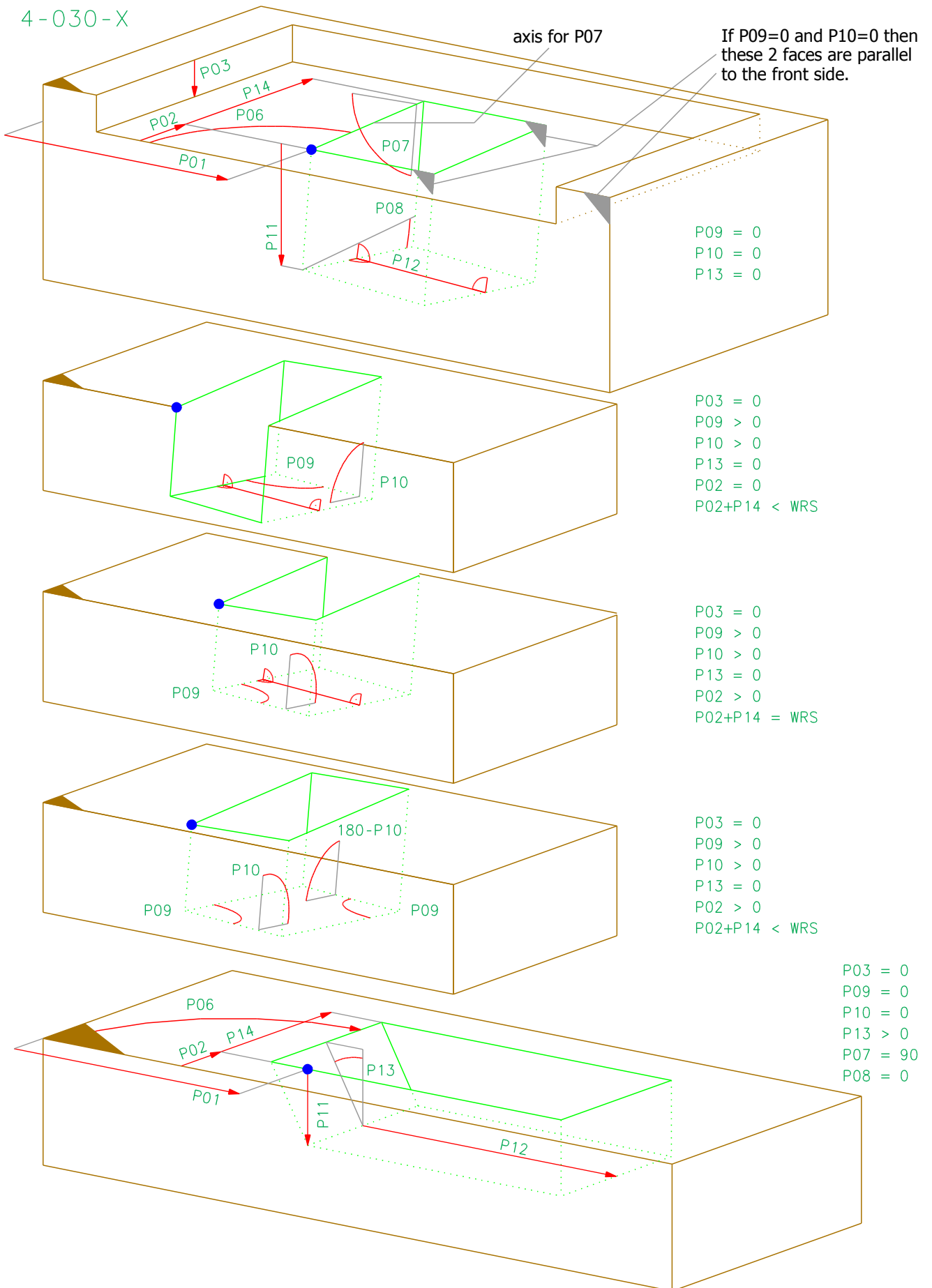

3-030-X

If $P09=0$ and $P10=0$ then these 2 faces are parallel to the front side.

axis for P07

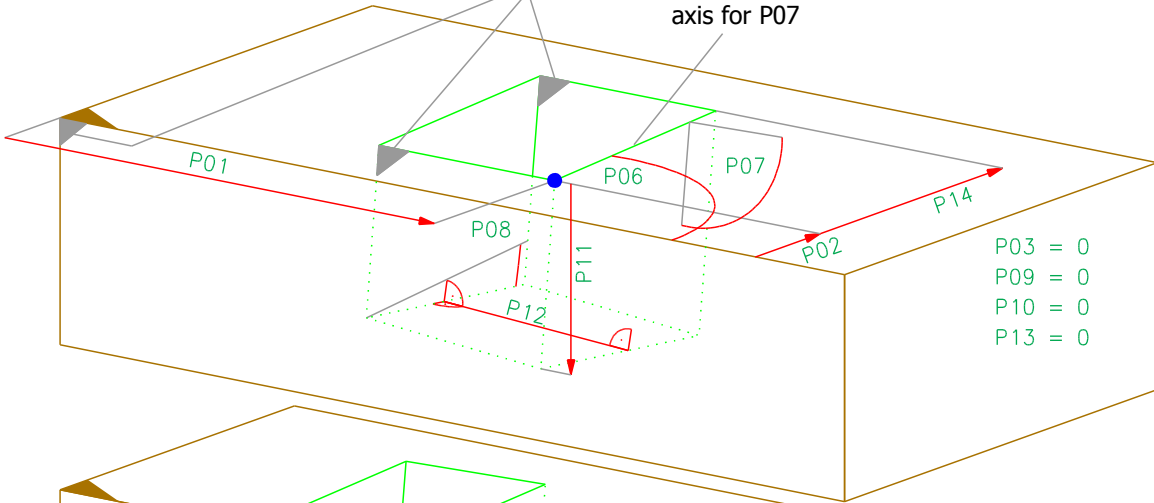

$P03 = 0$
 $P09 = 0$
 $P10 = 0$
 $P13 = 0$

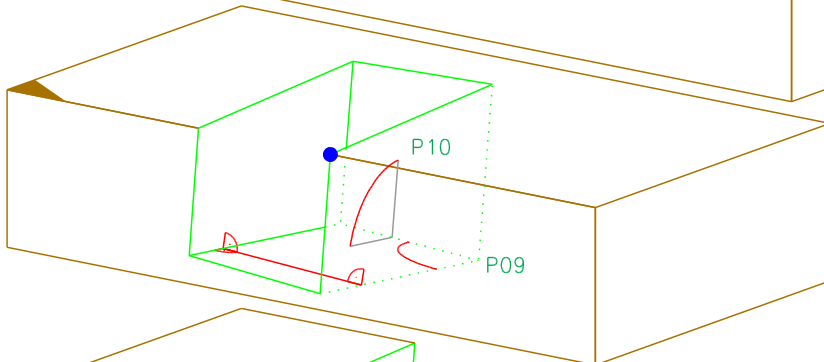

$P03 = 0$
 $P09 > 0$
 $P10 > 0$
 $P13 = 0$
 $P02 = 0$
 $P02+P14 < WRS$

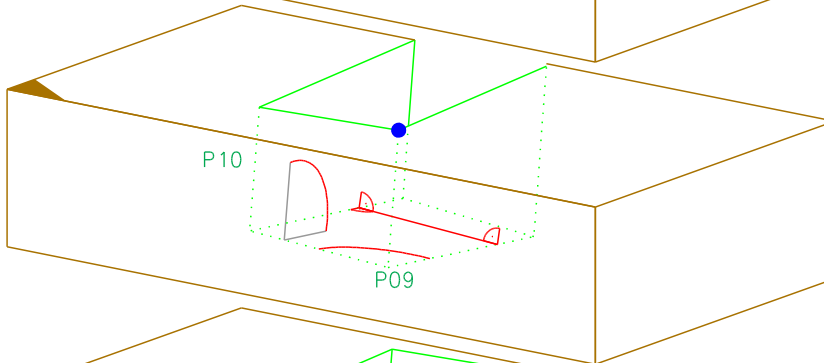

$P03 = 0$
 $P09 > 0$
 $P10 > 0$
 $P13 = 0$
 $P02 > 0$
 $P02+P14 = WRS$

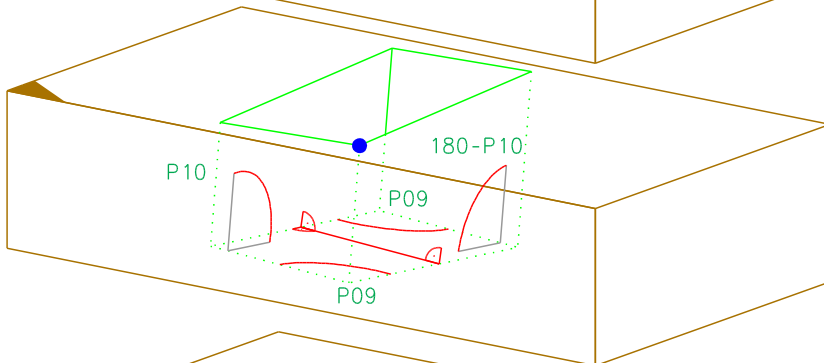

$P03 = 0$
 $P09 > 0$
 $P10 > 0$
 $P13 = 0$
 $P02 > 0$
 $P02+P14 < WRS$

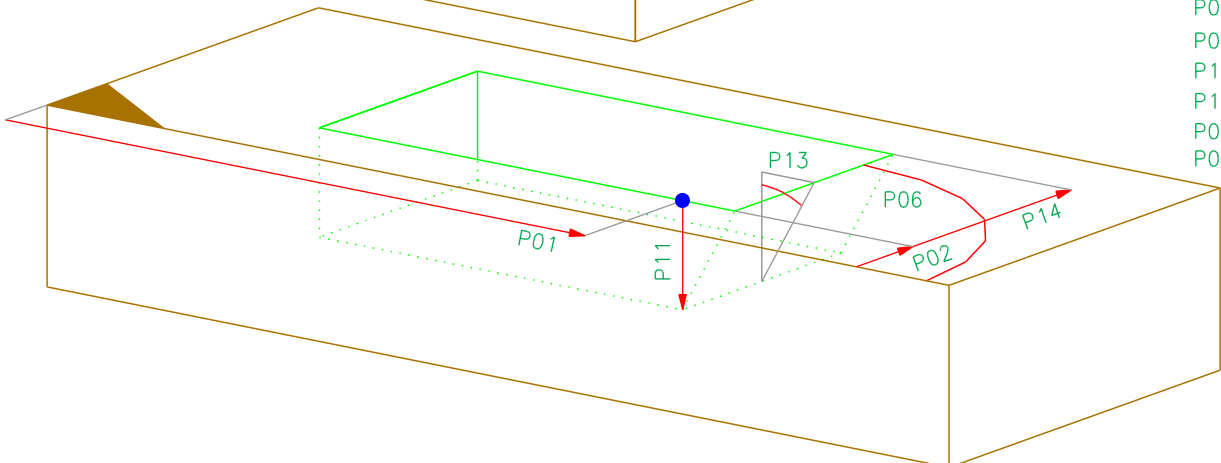

$P03 = 0$
 $P09 = 0$
 $P10 = 0$
 $P13 > 0$
 $P07 = 90$
 $P08 = 0$

1.10 Parameters Lap Joint 3-030-X and 4-030-X

Parameter	Min/Max	Presetting	Description
P01	+/- 99999	0	Distance from beam start to the reference point
P02	+/- 50000	0	Distance from the reference edge to the reference point
P03	0/50000	0	Displacement to the reference side
P04	0/15	0	Limit of the 4 sides of the lap, binary code
P06	1/179	90	Angle to the reference edge in the reference side
P07	1/179	90	Inclination to the reference side
P08	-89/89	0	Angle between edge and reference side in face
P09	0/179	0	Angle in the floor face
P10	0/179	0	Angle between base face and one face of lap
P11	+/- 50000	HRS/2	Distance from the reference side to the reference point (orthogonal)
P12	1/99999	100	Length
P13	0/89	0	Chamfer angle
P14	0/50000	WRS	Grooving depth (length of the lapped scarf in transverse direction) If P14 is zero, then its value must be calculated: $P14=WRS-P02$

P04

This parameter describes, if the lap leaks out of the reference face.
Also for the laps 030, 037 and 032.
A reference face has four edges, so the information is described with binary code.

0=edge is limited
1=edge is open

Bit 1: begin of piece
Bit 2: end of piece
Bit 3: reference edge
Bit 4: opposite to the reference edge

Bit 4: opposite to the reference edge

Bit 1: begin of piece

Bit 2: end of piece

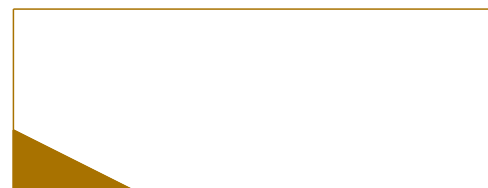

Bit 3: reference edge

Example:

P04=0

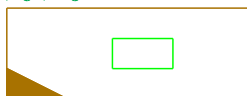

P04=2



P04=6

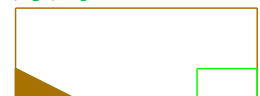

P04=1

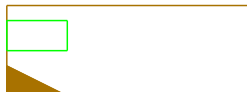

P04=8



P04=4



P04=12



1.11 Notch/Rabbet 3-032-X and 4-032-X

4-032-X

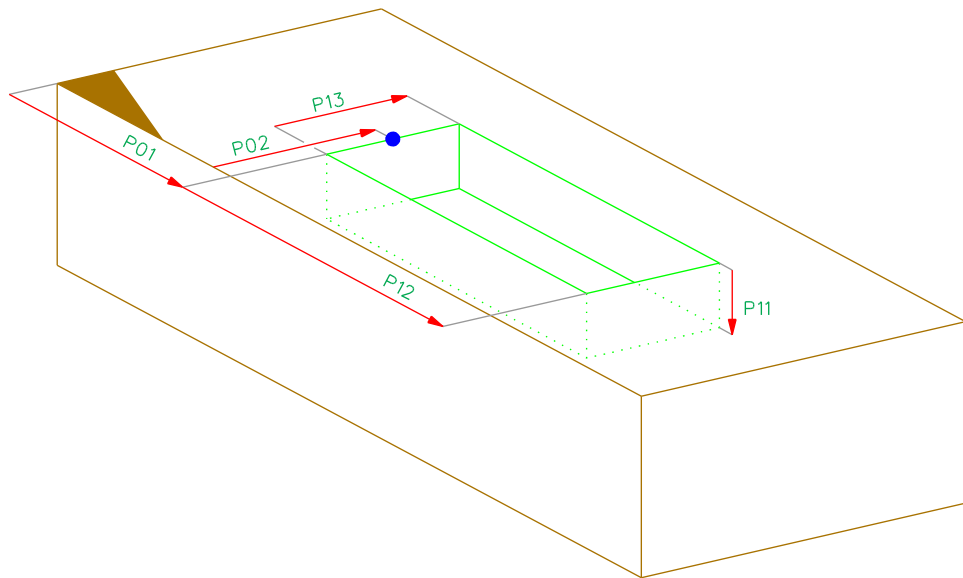

3-032-X

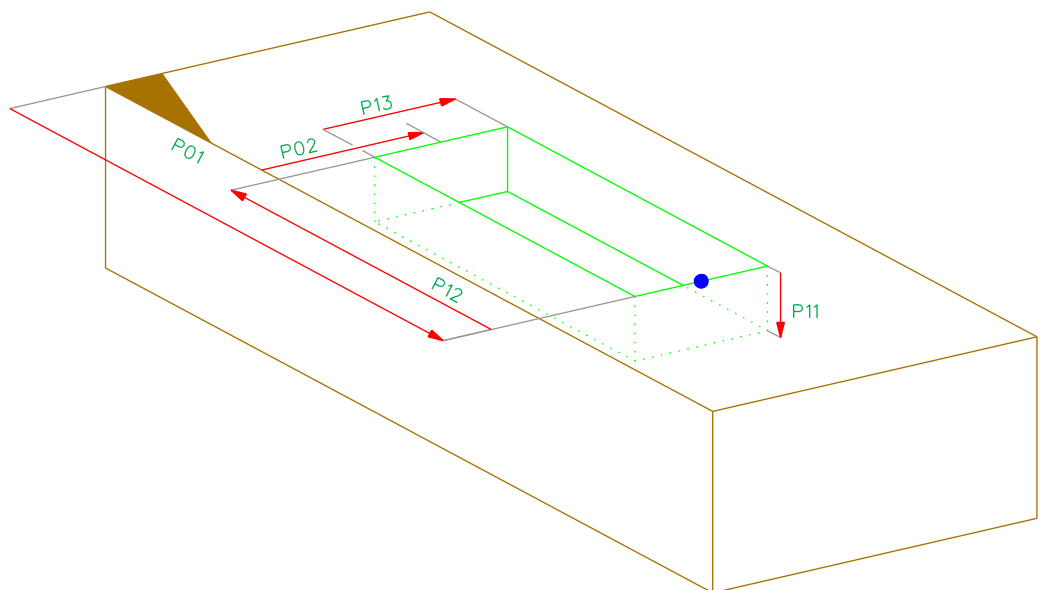

1.11 Parameters Notch/Rabbet

3-032-X und 4-032-X

Parameter	Min/Max	Presetting	Description
P01	+/- 99999	0	Distance from beam start to the reference point
P02	0/50000	0	Distance from the reference edge to the reference point
P04	0/15	0	Limit of the 4 sides of the lap, binary code See description of P04 for the Lap Joint 3,4-030-X
P11	0/50000	20	Notch/Rabbet depth
P12	0/99999	20	Notch/Rabbet length
P13	1/50000	200	Notch/Rabbet width

1.12 Block House Half Lap, Stair Riser Dado 3-033-X and 4-033-X

4-033-X

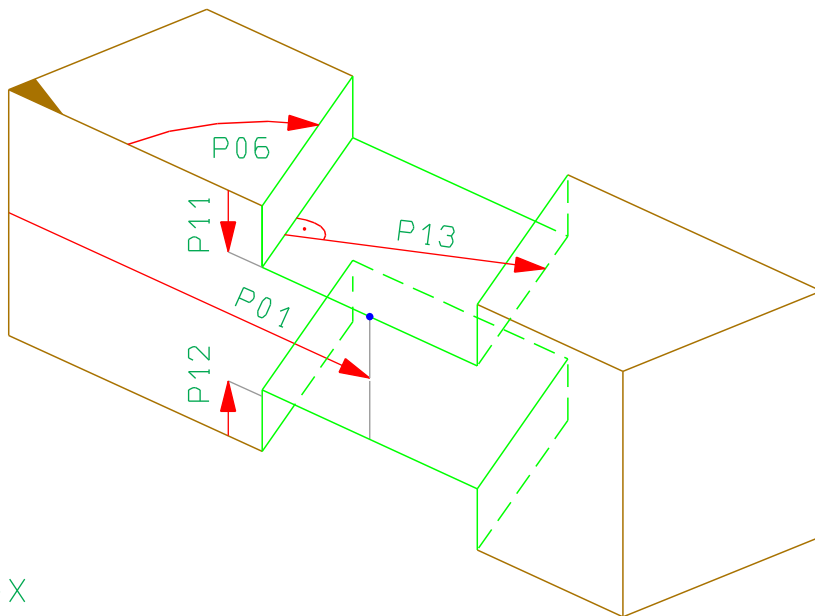

3-033-X

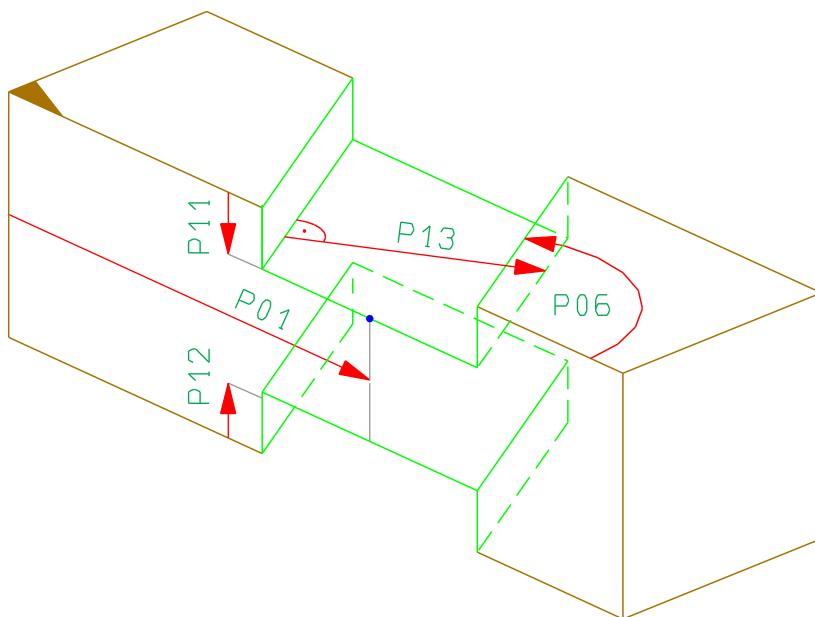

1.12 Parameters Block House Half Lap, Stair Riser Dado 3-033-X and 4-033-X

Parameter	Min/Max	Presetting	Description
P01	+/- 99999	0	Distance from beam start to the reference point
P06	1/179	90	Angle between cut edge and reference edge
P11	0/HWS	20	Depth of the Half Lap on the reference side
P12	0/HWS	20	Depth of the Half Lap opposite of the reference side
P13	1/50000	WRS	Length of the Half Lap / Dado

1.13 Seathing Cut 3-034-X and 4-034-X

4-034-X

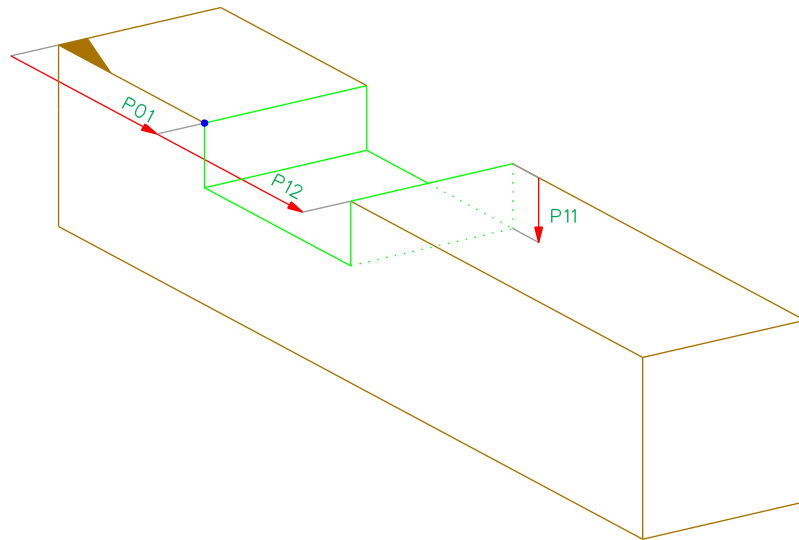

3-034-X

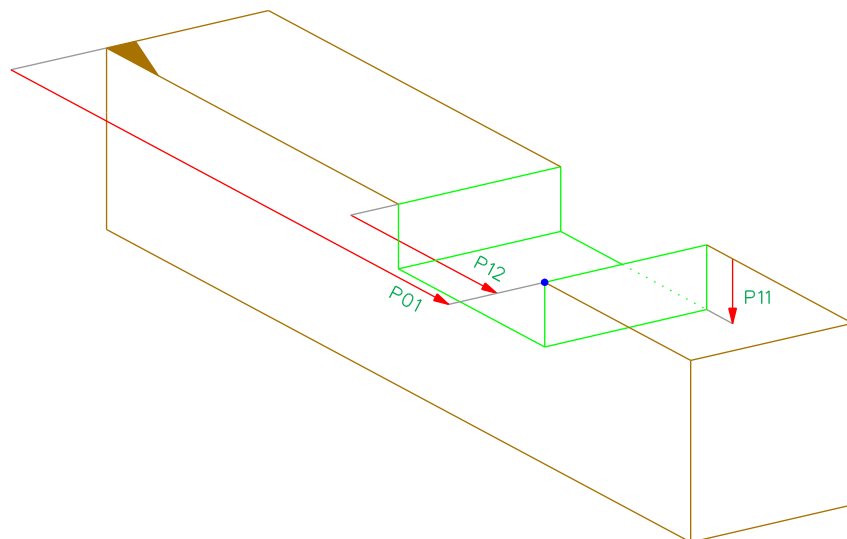

1.13 Parameters Seathing Cut

3-034-X and 4-034-X

Parameter	Min/Max	Presetting	Description
P01	+/- 99999	0	Distance from beam start to the reference point
P11	0/HWS	1	Depth of Seathing Cut
P12	1/99999	LRS	Length of Seathing Cut

1.14 French Ridge Lap 1-035-X and 2-035-X

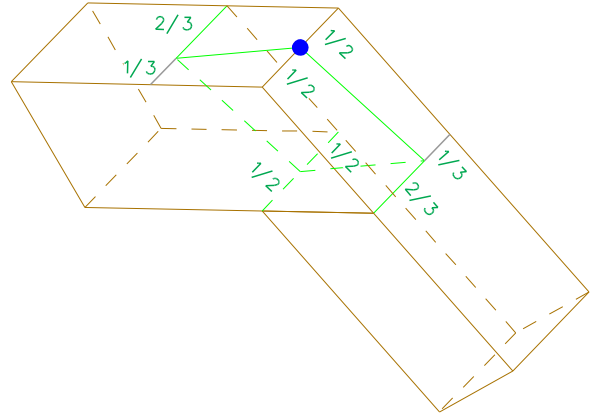
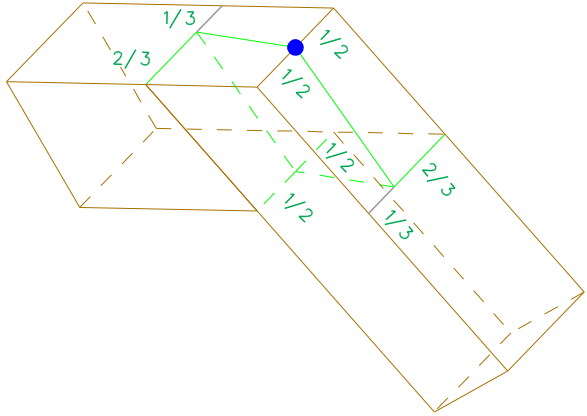

The length of the lap is equal to the width of reference side.

2-035-X

P02=0

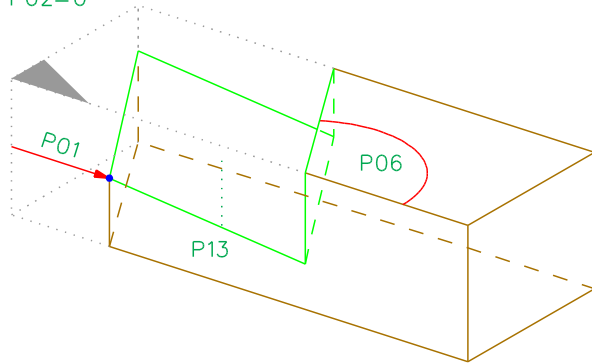

2-035-X

P02=1

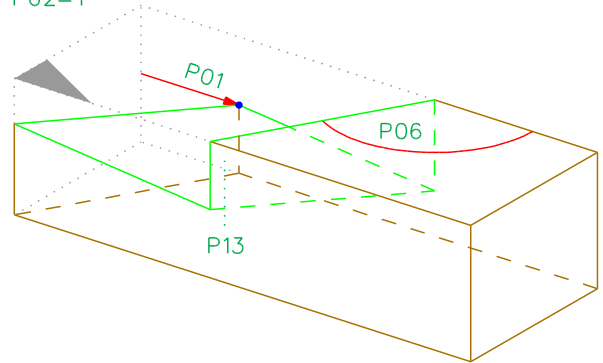

1-035-X

P02=1

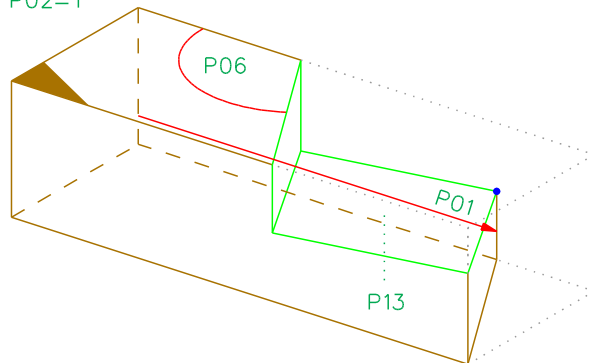

1-035-X

P02=0

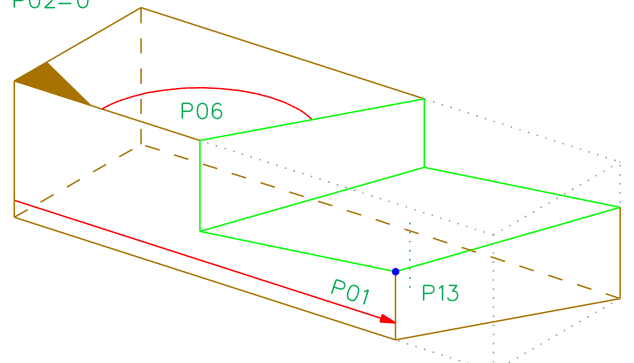

1.14 Parameters French Ridge Lap

1-035-X and 2-035-X

Parameter	Min/Max	Presetting	Description
P01	+/- 99999	0	Distance from beam start to the reference point
P02	0/1	0	0: Reference point on reference edge 1: Reference point on the opposite edge
P06	1/179	90	Angle to the reference edge in the reference side
P13	0/1000	0	Drill hole diameter

1.15 Chamfer 3-036-X and 4-036-X

4-036-X

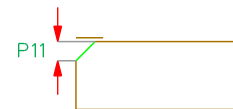
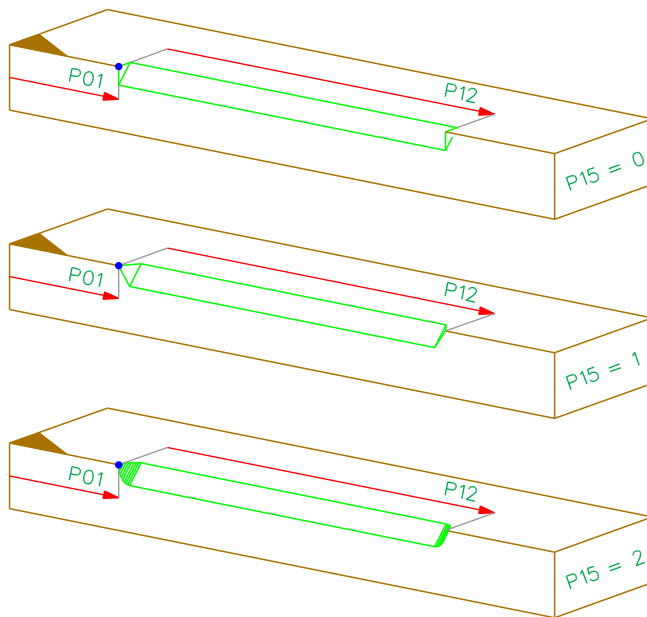

3-036-X

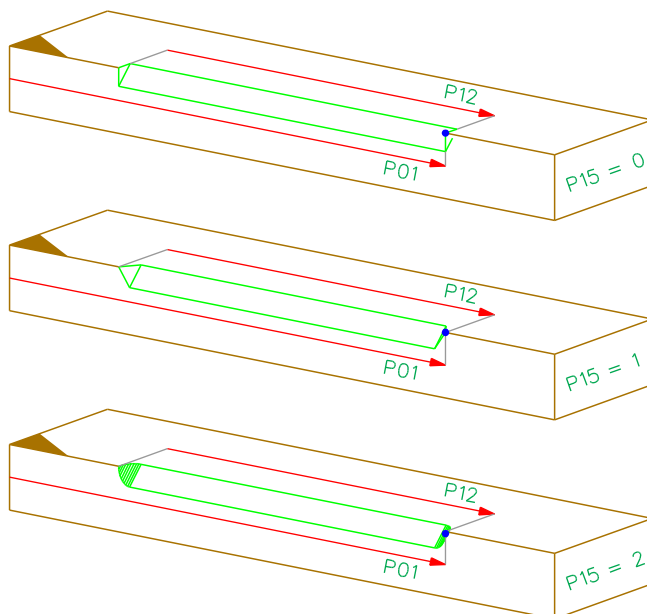

1.15 Parameters Chamfer

3-036-X and 4-036-X

Parameter	Min/Max	Presetting	Description
P01	+/- 99999	0	Distance from beam start to the reference point
P04		1	Input of edge(s) to be beveled, binary code: Bit 0=edge 1 ; Bit 1=edge 2; Bit 2=edge 3; Bit 3=edge 4 Example: P04=9: edge 1+4; P04=3: edge 1+2
P11	0/1000	1	Depth
P12	0/99999	LRS	Length If P12 is equal to zero, the processing is performed along the whole component length.
P15	0,1,2	0	Shape for bevel exit: 0 = orthogonal, 1 = at 45 deg, 2 = round;

1.16 Block House Half Lap 4-037-X

P04 = 0

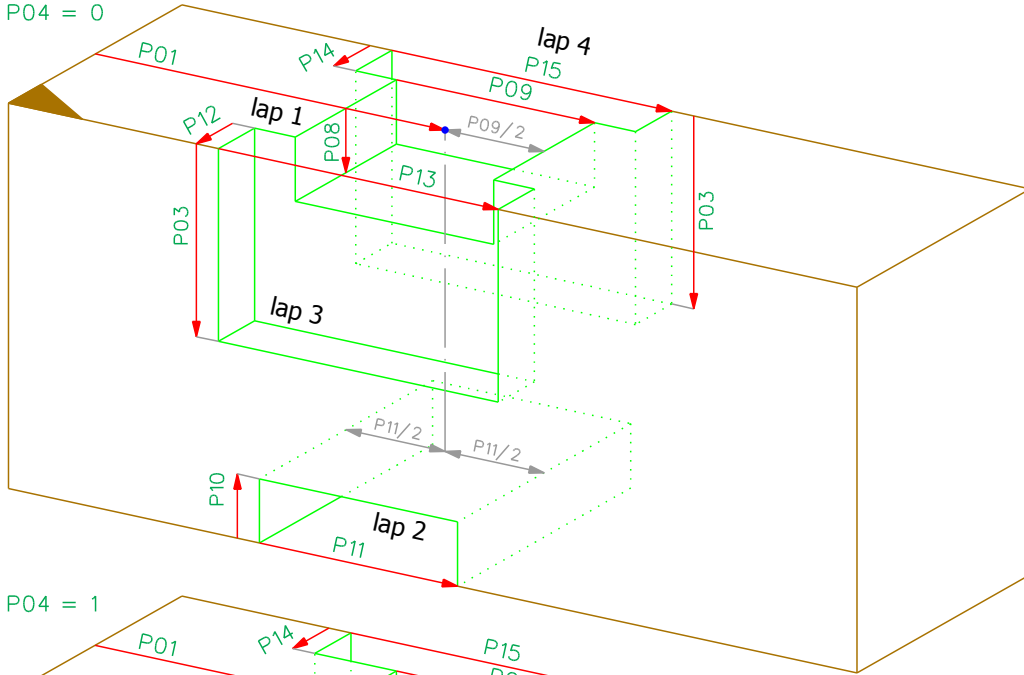

P04 = 1

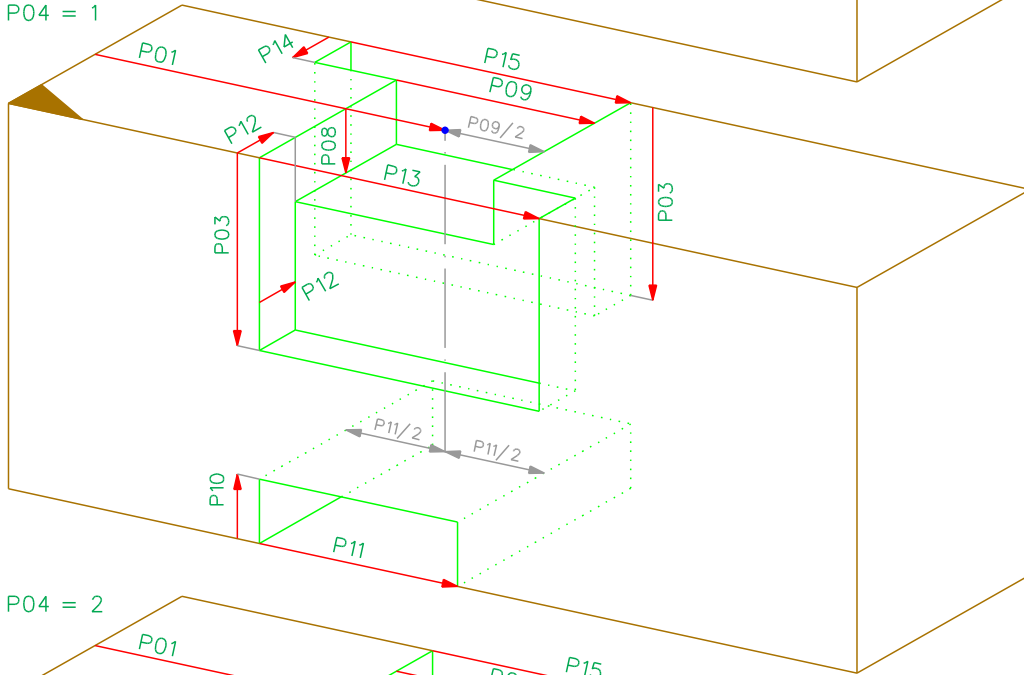

P04 = 2

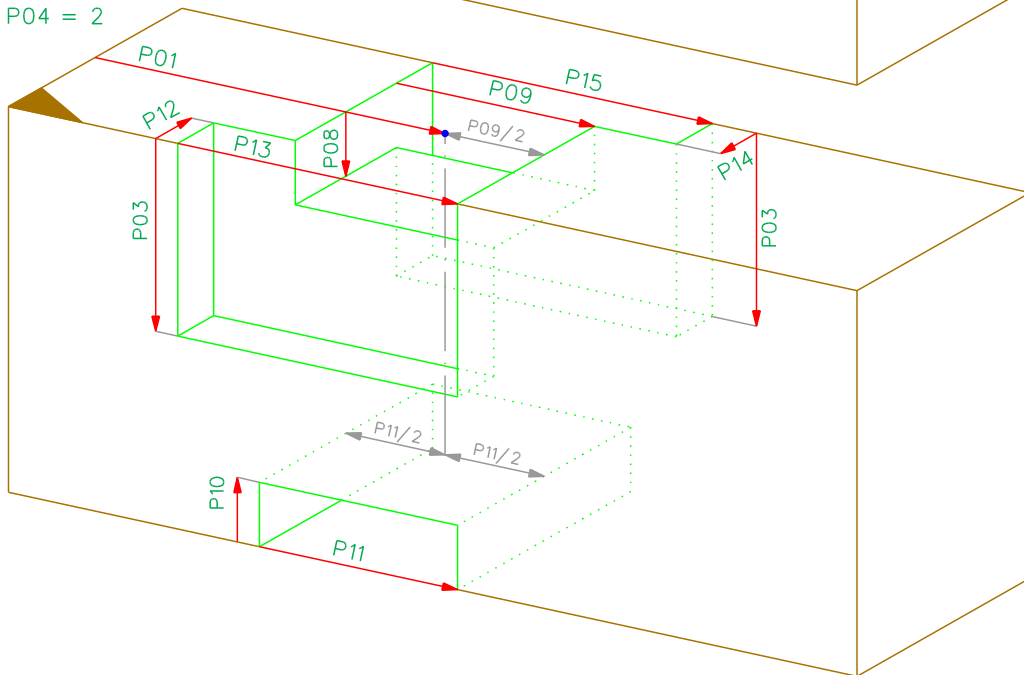

1.16 Parameters Block House Half Lap

4-037-X

Parameter	Min/Max	Presetting	Description
P01	+/- 99999	0	Distance from beam start to the reference point
P03		0	Depth orthogonal to reference side of the lap 2 and 4. If P03 is zero, then its value must be calculated: $P03 = HRS$
P04		0	0: all laps are symmetric to each other 1: lap on reference edge moved to end beam lap in opposite of reference edge moved to start beam 2: lap on reference edge moved to start beam lap in opposite of reference edge moved to end beam
P08	0/50000	10	lap 1: Depth
P09	0/50000	100	lap 1: Length
P10	0/50000	10	lap 2: Depth
P11	0/50000	100	lap 2: Length
P12	0/50000	10	lap 3: Depth
P13	0/50000	100	lap 3: Length
P14	0/50000	10	lap 4: Depth
P15	0/50000	100	lap 4: Length

1.17 Block House Front 3-038-X and 4-038-X

4-038-X

P04=1

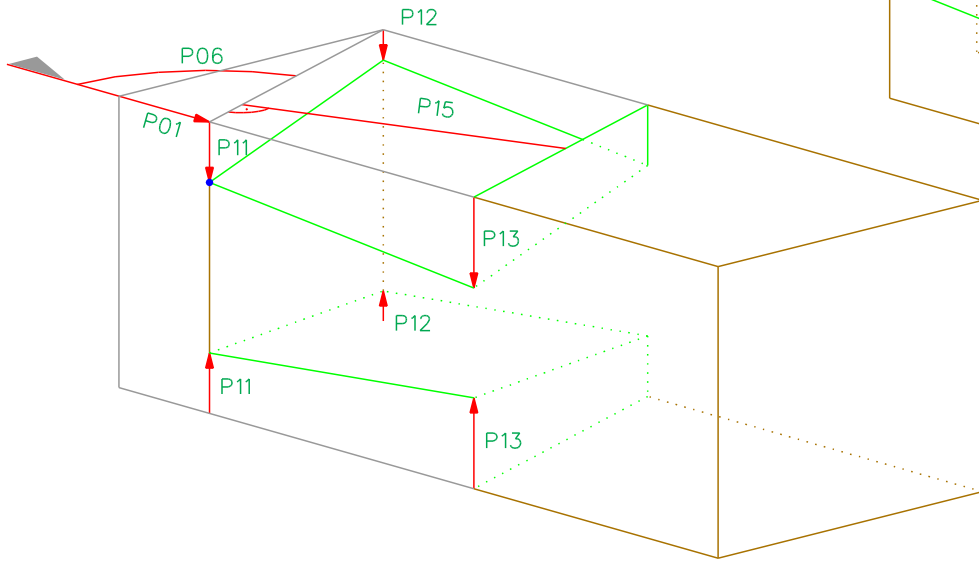

P04=0

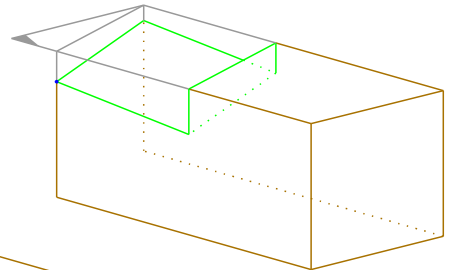

3-038-X

P04=1

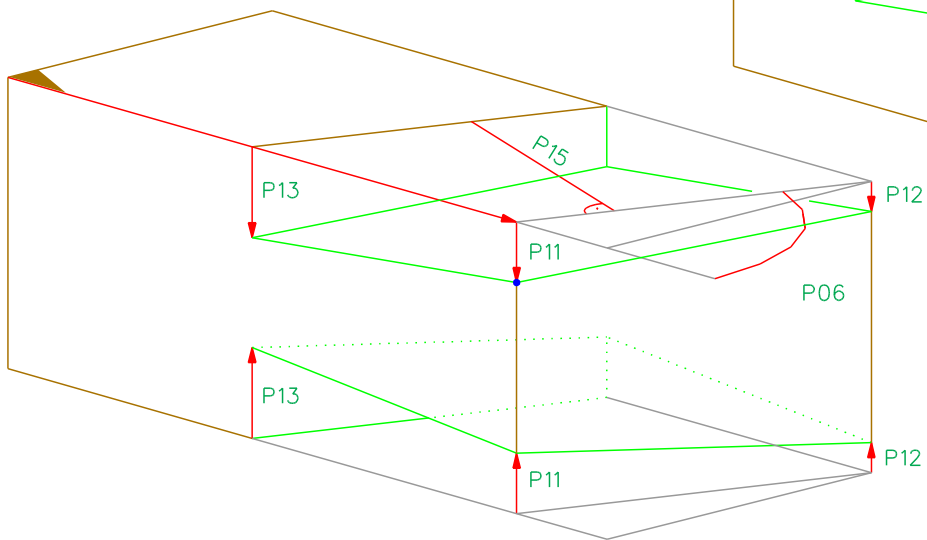

P04=0

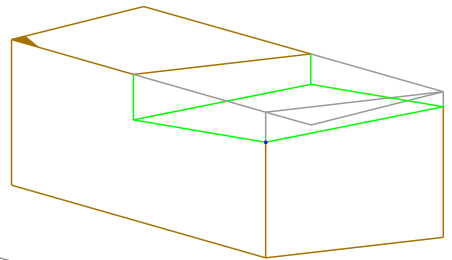

1.17 Parameters Block House Front

3-038-X and 4-038-X

Parameter	Min/Max	Presetting	Description
P01	+/- 99999	0	Distance from beam start to the reference point
P04	0/1	0	0: only one lap on reference side 1: one lap on reference side and one on the opposite side
P06	1/179	90	Angle to the reference edge in the reference side
P11	+/- 50000	15	Depth at reference point
P12	+/- 50000	10	Depth opposite to the reference point
P13	+/- 50000	25	Depth at reference edge
P15	0/50000	100	Length

1.18 Pocket 4-039-X

4-039-X

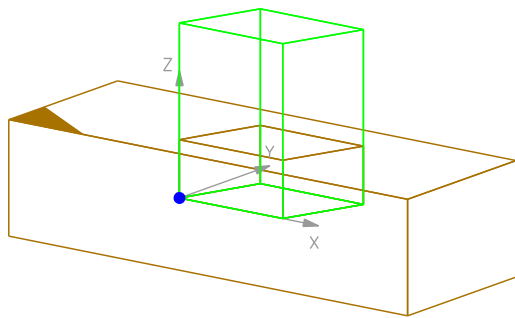
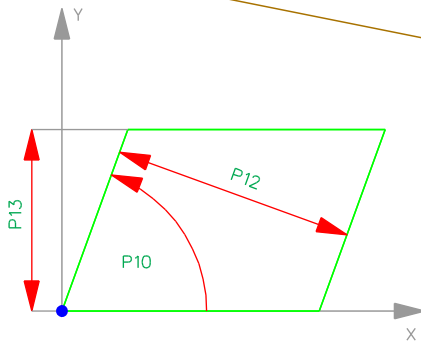
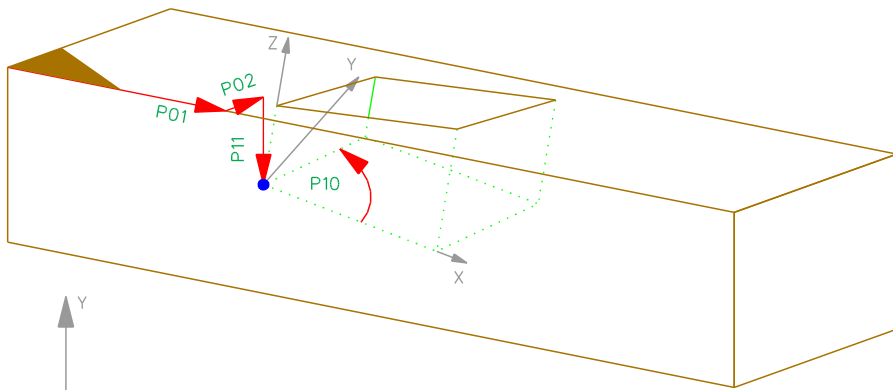

==>

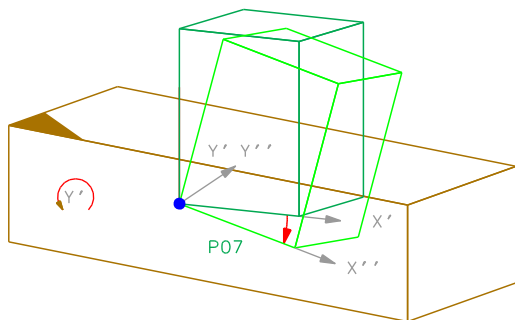
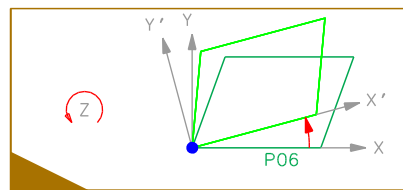

==>

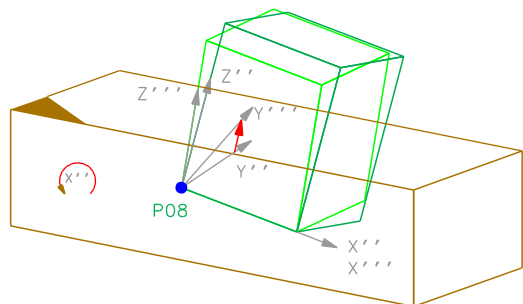

1.18 Parameters Pocket

4-039-X

Parameter	Min/Max	Presetting	Description
P01	+/- 99999	0	Distance from beam start to the reference point
P02	0/50000	0	Distance from the reference edge to the reference point
P04	0/15	0	Limit of the 4 sides of the lap, binary code Example: SCALEUNIT=2, P04=00000300, value=3.
P06	-179/179	0	Rotation angle around the local z-axis of the cuboid
P07	-179/179	0	Rotation angle around the local y-axis of the cuboid, rotated with P06
P08	-179/179	0	Rotation angle around the local x-axis of the cuboid, rotated with P06 and P07
P10	1/179	0	Internal angle at the reference point
P11	+/- 50000	20	Depth of reference point orthogonal to reference side
P12	1/50000	20	Length of Half Lap
P13	0/50000	100	Width of Half Lap

1.19 Drilling 3-040-X und 4-040-X

4-040-X
 $P03 = 0$

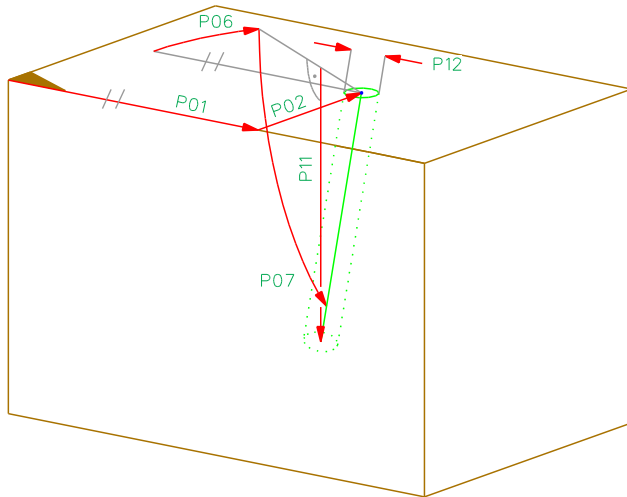

3-040-X
 $P03 = 0$

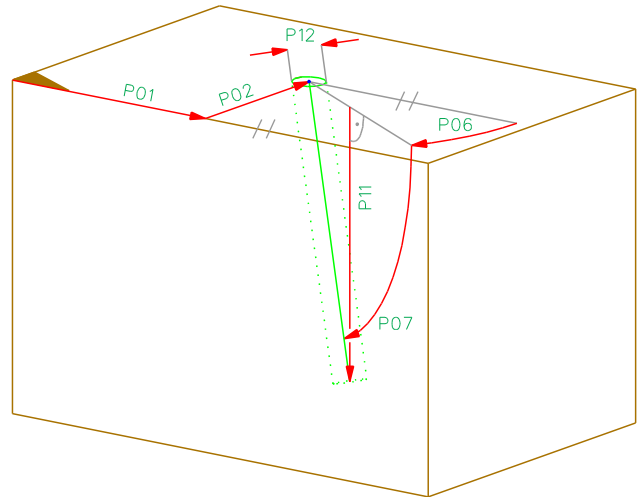

4-040-X
 $P03 <> 0$

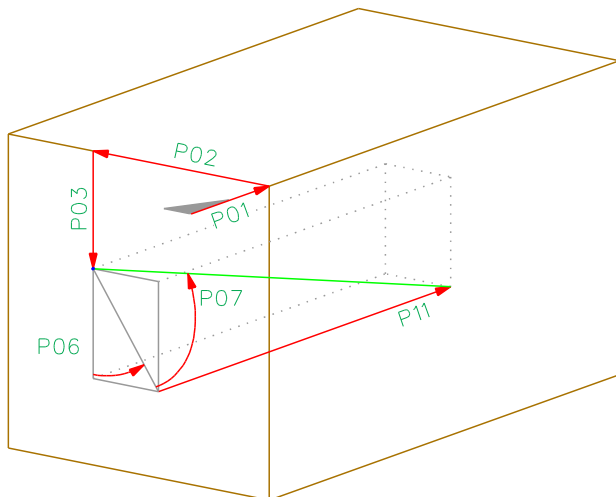

3-040-X
 $P03 <> 0$

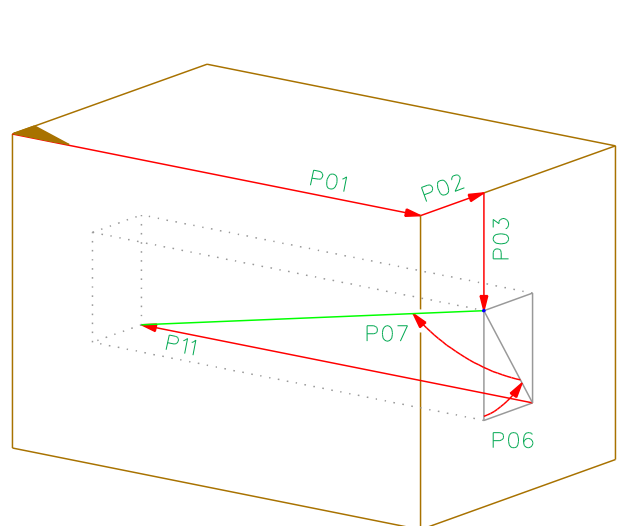

1.19 Parameters Drilling

3-040-X and 4-040-X

Parameter	Min/Max	Presetting	Description
P01	+/- 99999	0	Distance from beam start to the reference point
P02	0/50000	0	Distance from the reference edge to the reference point
P03	0/HRS	0	Distance from the reference face to the reference point P03 = 0: Drilling on one of the 4 sides of the component. P03 <> 0: Drilling on one of the 2 front sides of the component
P06	0/360	90	P03 = 0: Angle to the reference edge in the reference side. P03 <> 0: Angle in the front side.
P07	1/179	45	Inclination between drilling and reference side P03 = 0: Inclination between drilling and reference side. P03 > 0: Inclination between drilling and front side.
P11	0/50000	HRS	Depth, orthogonal to reference side or front side.
P12	0/1000	20	Drill hole diameter

1.20 Tenon 1-050-X and 2-050-X

2-050-X

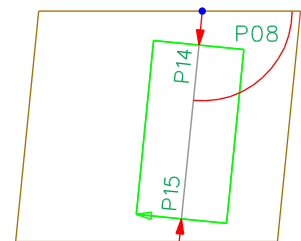
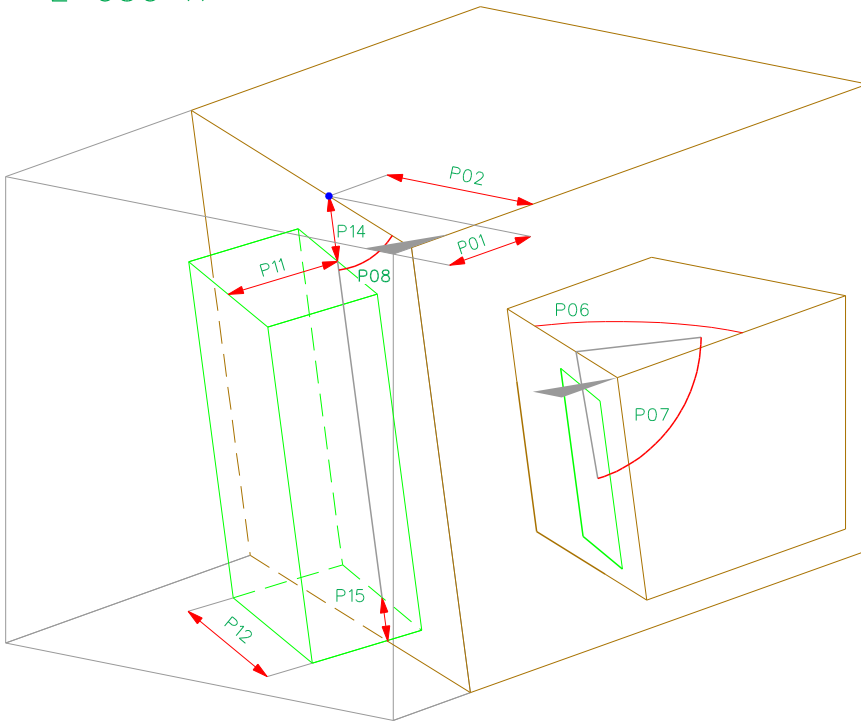

1-050-X

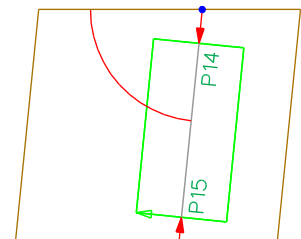
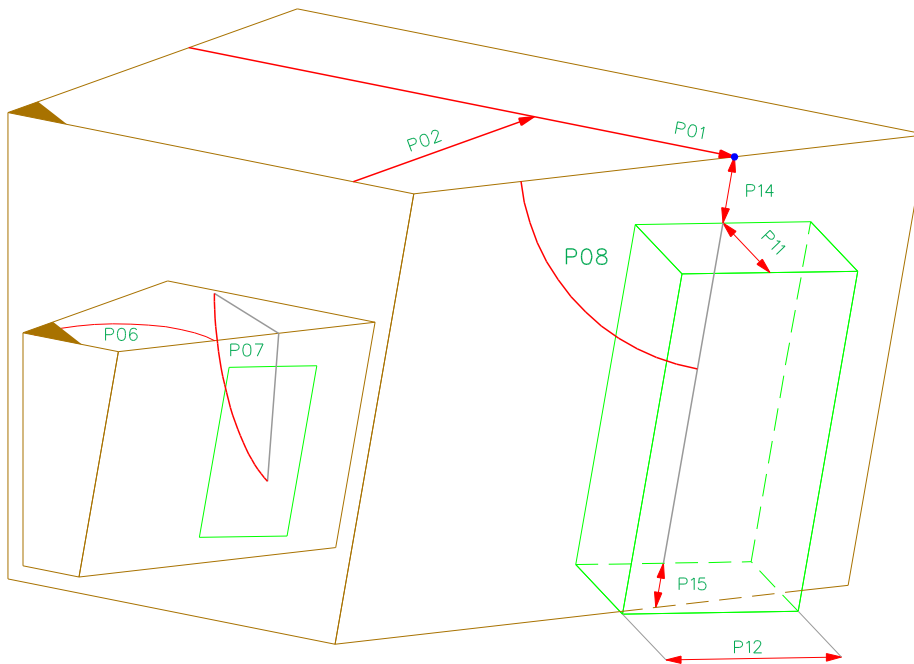

P05=0

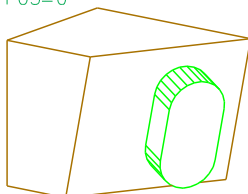

P05=1

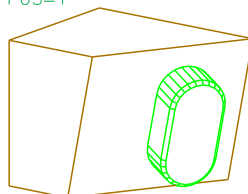

1.20 Parameters Tenon

1-050-X and 2-050-X

Parameter	Min/Max	Presetting	Description
P01	+/- 99999	0	Distance from beam start to the reference point
P02	0/50000	WRS/2	Distance from the reference edge to the reference point
P04	0/1/2/3/4	90	Rounding
P05	0/1	0	Chamfer
P06	1/179	90	Angle between cut edge and reference edge
P07	1/179	90	Inclination between face and reference side
P08	1/179	90	Angle between axis of the tenon and reference side
P10	0/500	0	Radius for P04=4
P11	1/1000	40	Tenon height
P12	1/1000	40	Tenon width
P14	+/- 1000	0	Margin on the reference side
P15	+/- 1000	0	Margin opposite the reference side

P04=0

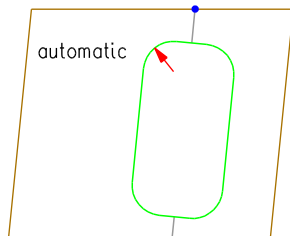

P04=1

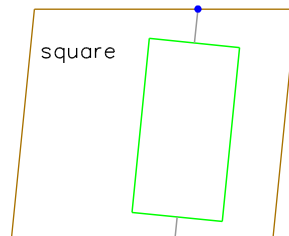

P04=2

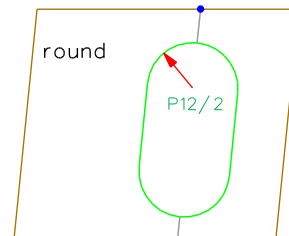

The tenon can be square, round or machine defined depending on the capabilities of the machine.

P04=3

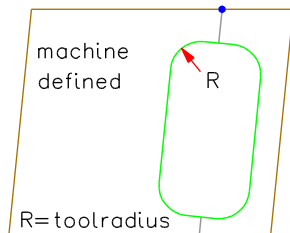

P04=4

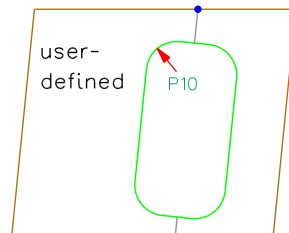

1.21 Mortise 3-050-X and 4-050-X

4-050-X

P08=90
P16=90

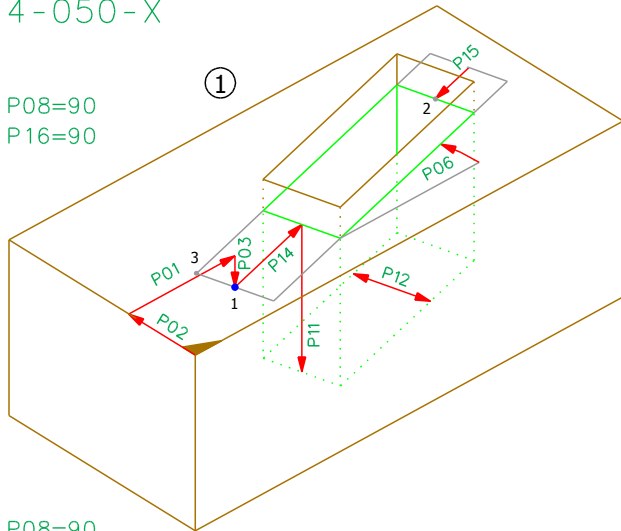

P08=90
P16=90-rotation_{1,3}

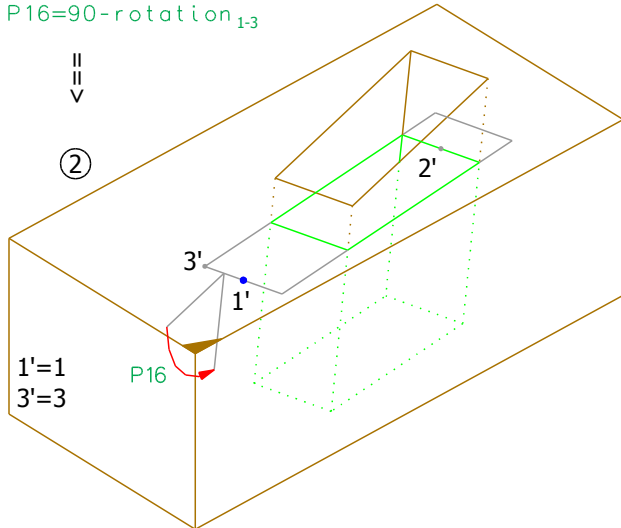

P08=90-rotation_{1',2'}

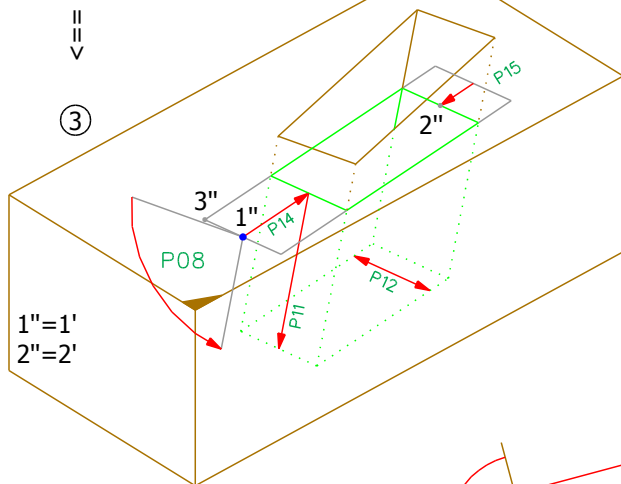

3-050-X

P08=90
P16=90

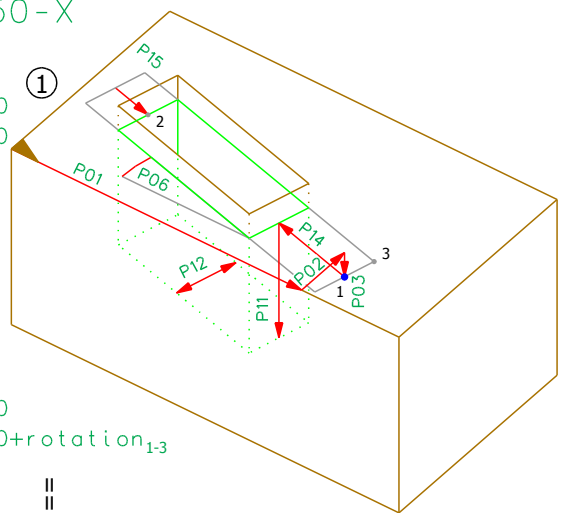

P08=90
P16=90+rotation_{1,3}

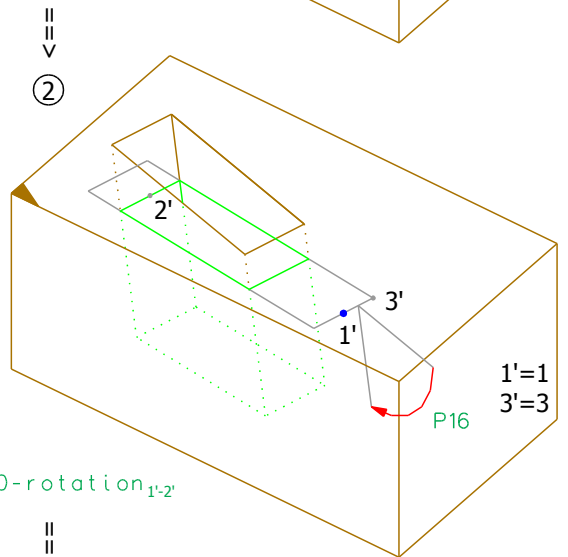

P08=90-rotation_{1',2'}

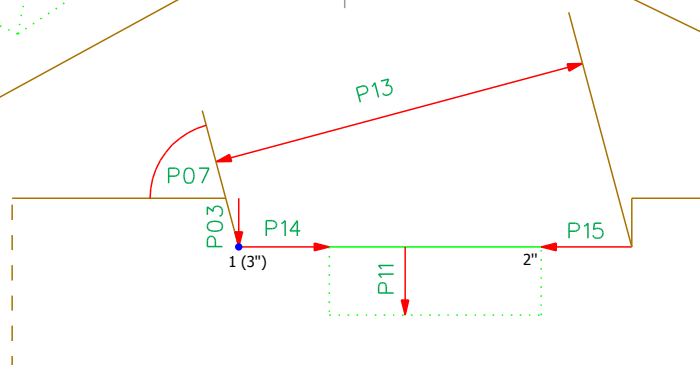
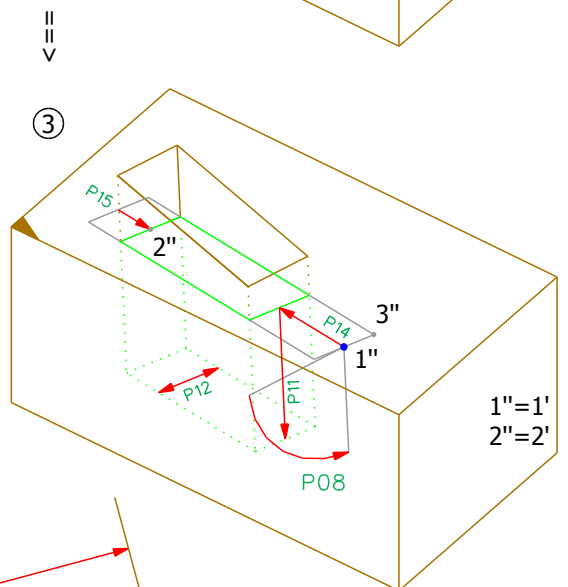

1.21 Parameters Mortise

3-050-X und 4-050-X

Parameter	Min/Max	Presetting	Description
P01	+/- 99999	0	Distance from beam start to the reference point
P02	+/- 50000	WRS/2	Distance from the reference edge to the reference point
P03	0/50000	0	Displacement to the reference side
P04	0/1/2/3/4	90	Rounding
P06	+/- 180	0	Angle between axis and reference edge
P07	1/179	90	Inclination between strut and reference side
P08	1/179	90	Inclination of hole side walls towards reference side
P10	0/500	0	Radius for P04=4
P11	0/1000	40	Mortise depth
P12	0/1000	40	Mortise width
P13	1/50000	200	Height of strut
P14	+/- 1000	0	Margin on the reference point
P15	+/- 1000	0	Margin opposite the reference point
P16	1/179	90	Inclination of hole front side towards reference side

P04=0

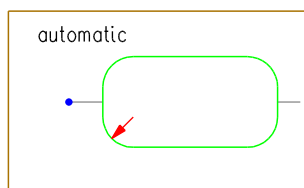

P04=1

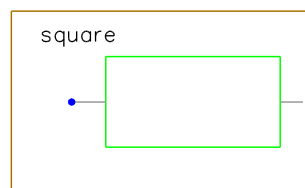

P04=2

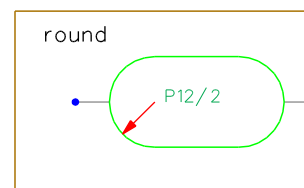

The mortise can be square, round or machine defined depending on the capabilities of the machine.

P04=3

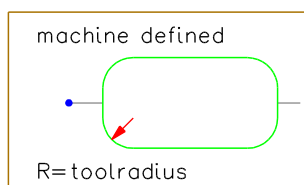

P04=4

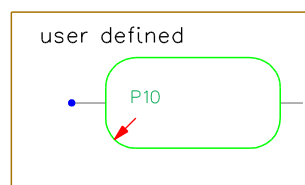

1.22 Mortise Front 3-051-X and 4-051-X

4-051-X

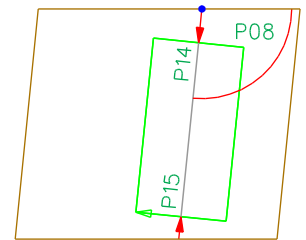
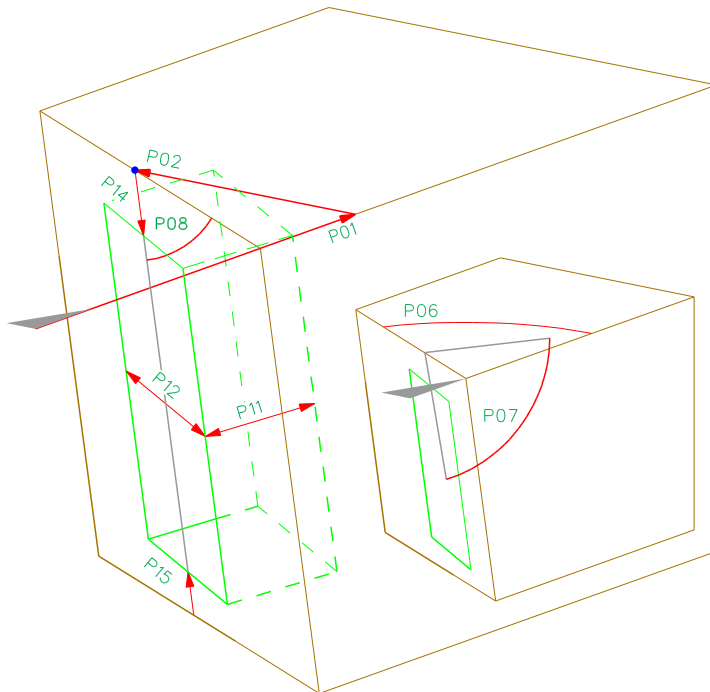

3-051-X

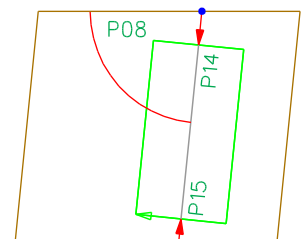
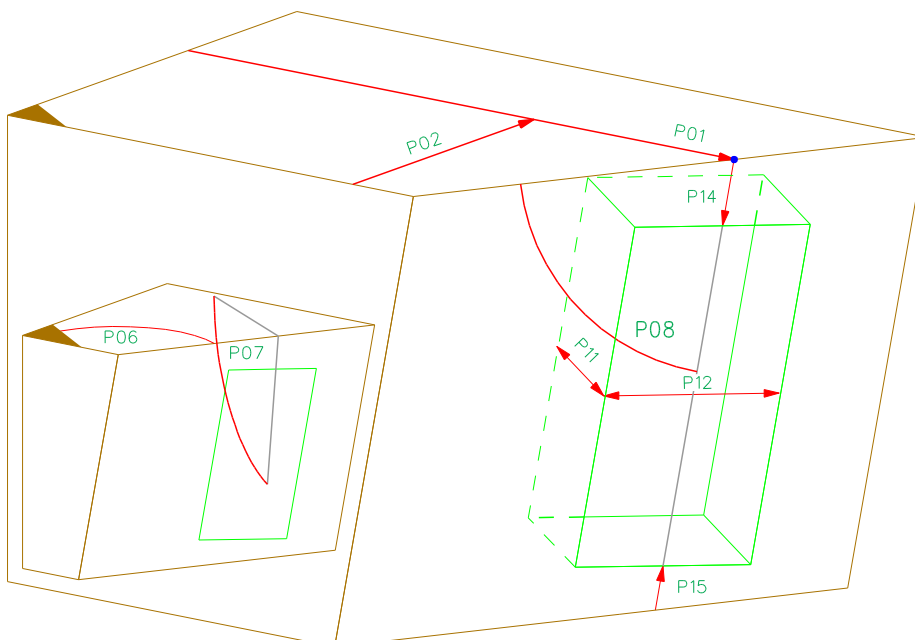

1.22 Parameters Mortise Front

3-051-X und 4-051-X

Parameter	Min/Max	Presetting	Description
P01	+/- 99999	0	Distance from beam start to the reference point
P02	0/50000	WRS/2	Distance from the reference edge to the reference point
P04	0/1/2/3/4	90	Rounding
P06	1/179	90	Angle between cut edge and reference edge
P07	1/179	90	Inclination between face and reference side
P08	1/179	90	Angle between axis of the tenon and reference side
P10	0/500	0	Radius for P04=4
P11	1/1000	40	Mortise depth
P12	1/1000	40	Mortise width
P14	+/- 1000	0	Margin on the reference side
P15	+/- 1000	0	Margin opposite the reference side

P04=0

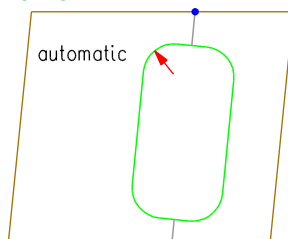

P04=1

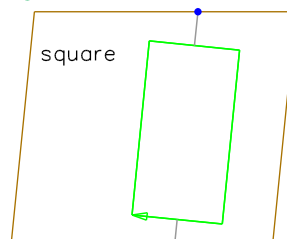

P04=2

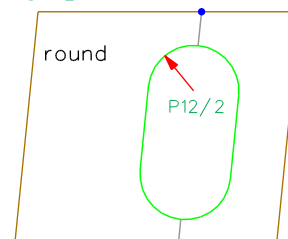

The mortise can be square, round or machine defined depending on the capabilities of the machine.

P04=3

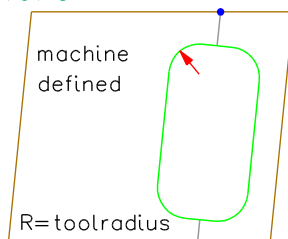

P04=4

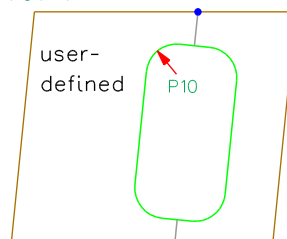

1.23 House 3-052-X and 4-052-X

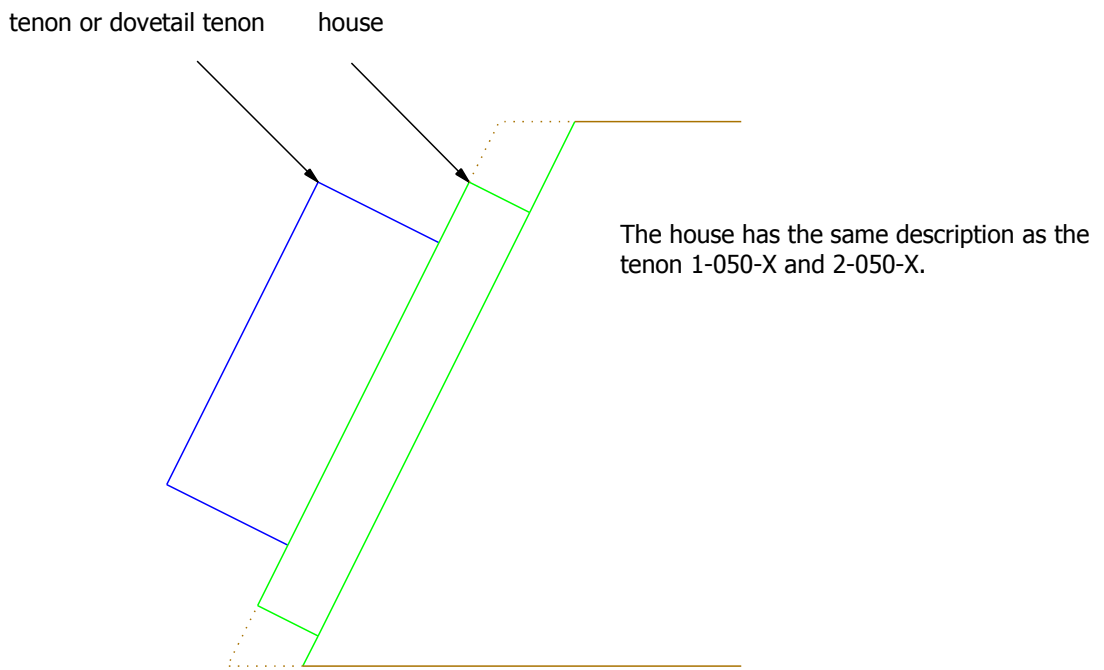

1.23 Parameters House

3-052-X and 4-052-X

The house has same parameters as 1-050-X and 2-050-X, except P09 and P05.

Parameter	Min/Max	Presetting	Description
P05	-	-	Not defined
P09	0/99999	0	Processident of the associated tenon or dovetail tenon

1.24 House Mortise 3-053-X and 4-053-X

The house mortise has the same description as the mortise 3-050-X and 4-050-X.

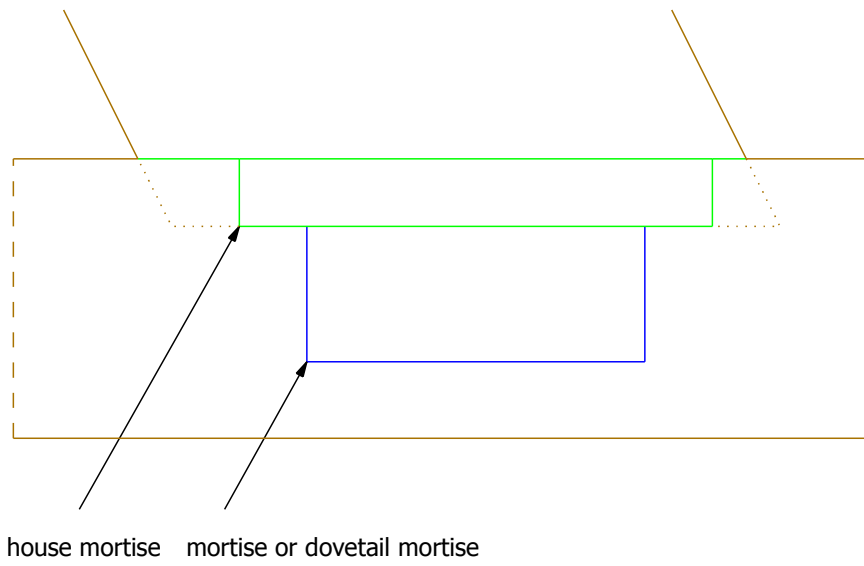

1.24 Parameters House Mortise

3-053-X and 4-053-X

The house mortise has same parameters as 3-050-X and 4-050-X, except P09.

Parameter	Min/Max	Presetting	Description
P09	0/99999	0	Processident of the associated mortise or dovetail mortise

1.25 Dovetail Tenon 1-055-X and 2-055-X

2-055-X

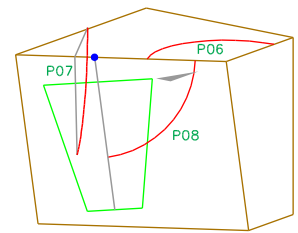
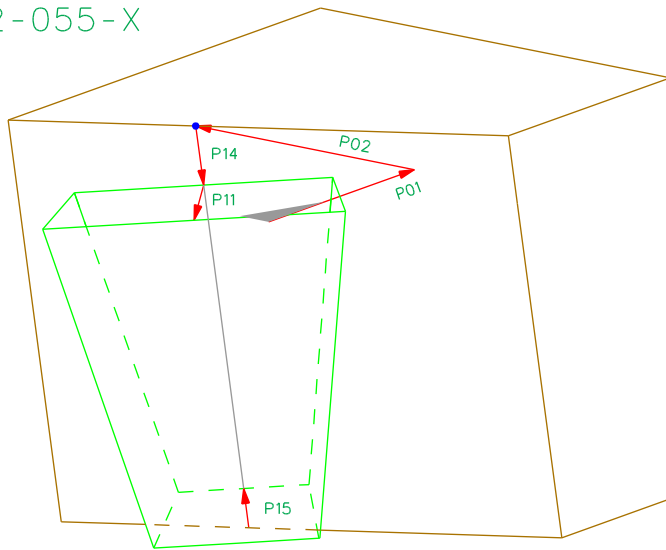

1-055-X

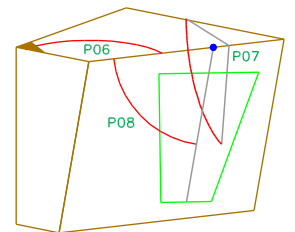
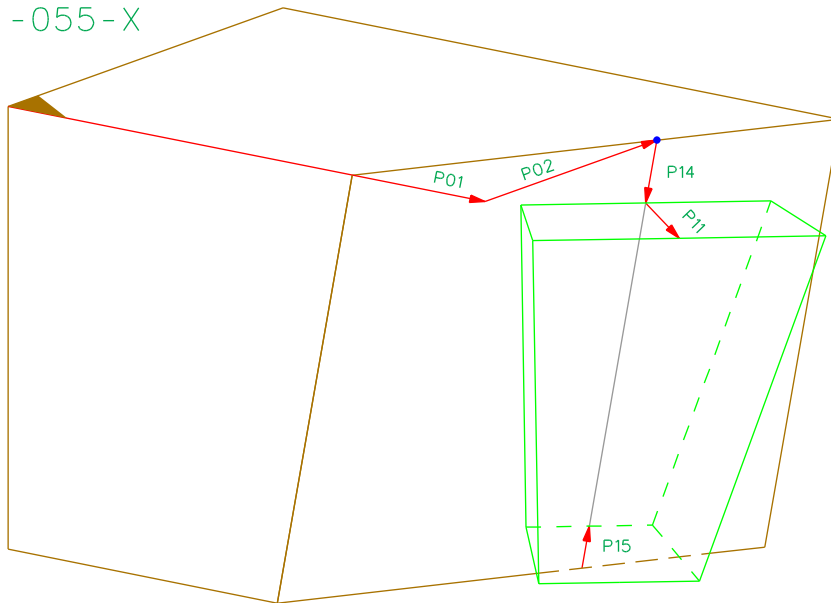

1.25 Parameters Dovetail Tenon

1-055-X and 2-055-X

Parameter	Min/Max	Presetting	Description
P01	+/- 99999	0	Distance from beam start to the reference point
P02	0/50000	WRS/2	Distance from the reference edge to the reference point
P06	1/179	90	Angle between edge and reference edge
P07	1/179	90	Inclination between face and reference side
P08	1/179	90	Angle between axis of the tenon and reference side
P09	0/1000	0	Middle flattening
P10	0/30	0	Angle of cone
P11	1/1000	28	Tenon height
P12	0/1000	45	Diameter of the curve
P14	0/1000	0	Margin on the reference side
P15	0/1000	0	Margin opposite the reference side

1.26 Dovetail Mortise 3-055-X and 4-055-X

4-055-X

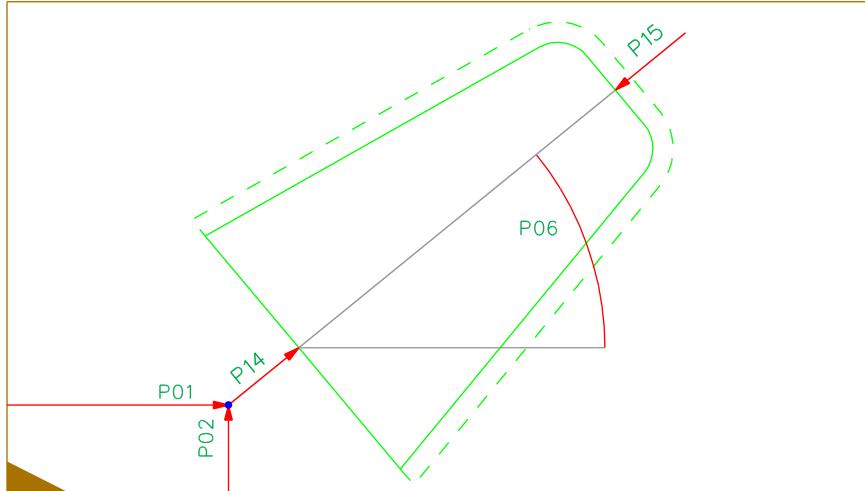

3-055-X

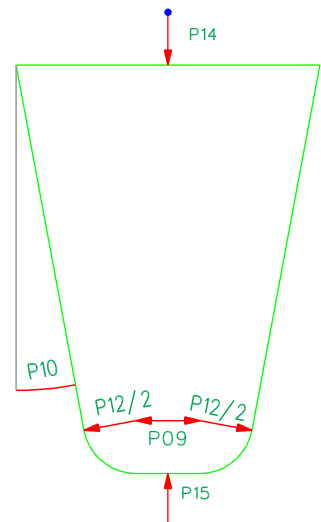
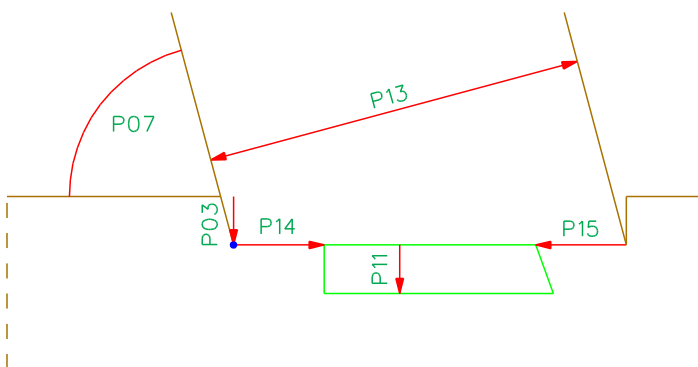
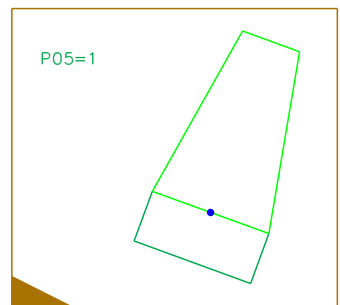
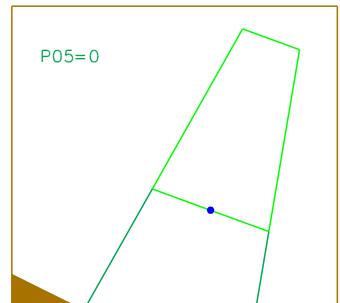
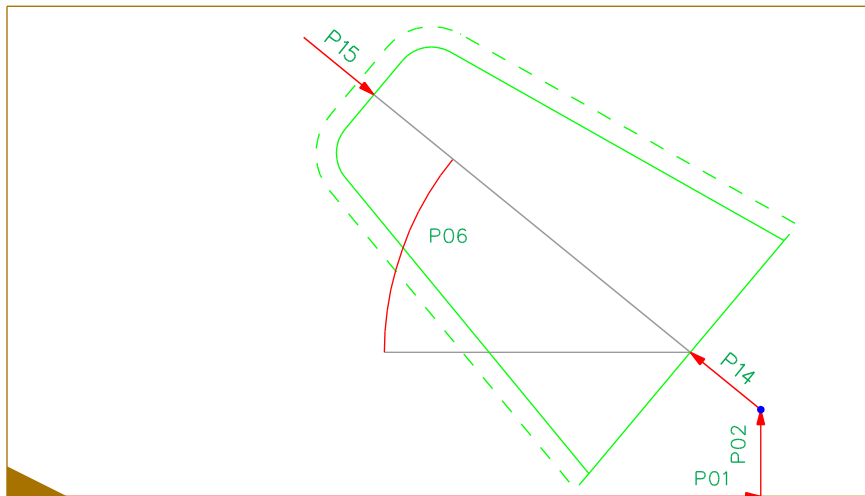

1.26 Parameters Dovetail Mortise

3-055-X und 4-055-X

Parameter	Min/Max	Presetting	Description
P01	+/- 99999	0	Distance from beam start to the reference point
P02	+/- 50000	WRS/2	Distance from the reference edge to the reference point
P03	0/50000	0	Displacement to the reference side
P05	0/1	0	0=with elongation; 1=with pocket
P06	+/- 180	0	Angle between axis and reference edge
P07	1/179	90	Inclination between strut and reference side
P09	0/1000	0	Middle flattening
P10	0/30	0	Angle of cone
P11	1/1000	28	Mortise depth
P12	0/1000	45	Diameter of the curve
P13	1/50000	200	Height of strut
P14	0/1000	0	Margin on the reference point
P15	0/1000	0	Margin opposite the reference point

1.27 Dovetail Mortise Front 3-056-X and 4-056-X

4-056-X

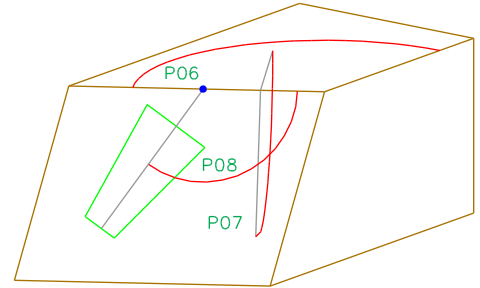
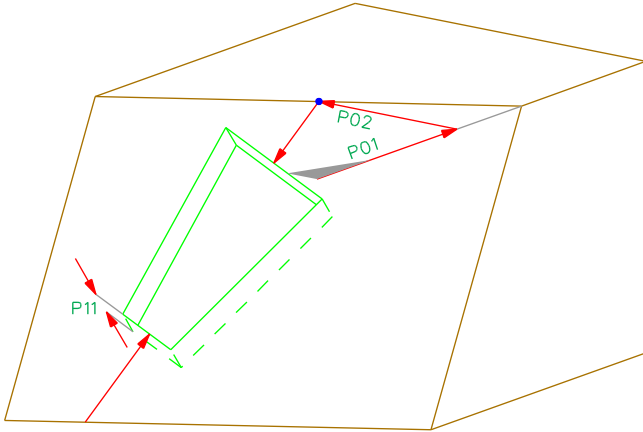

3-056-X

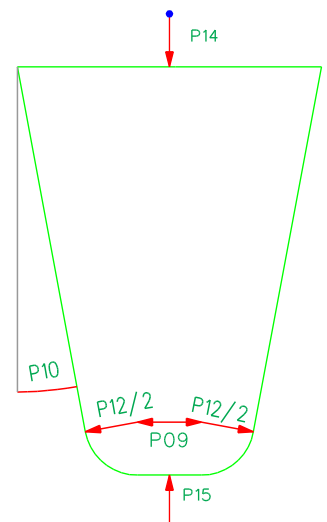
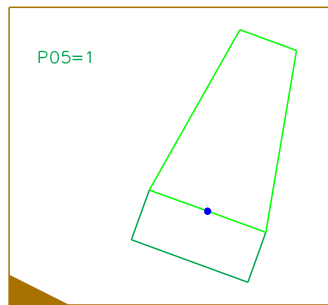
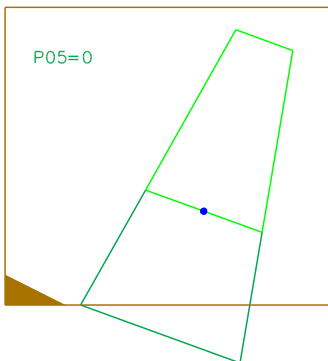
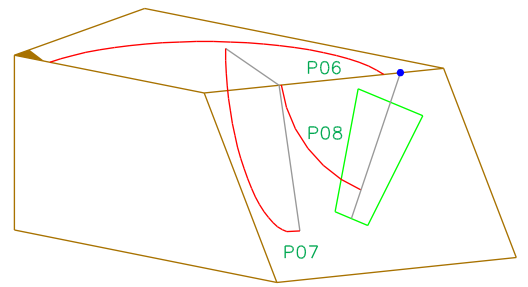
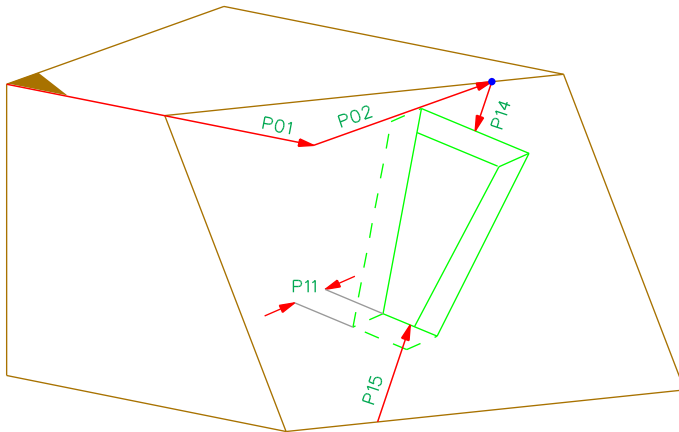

1.27 Parameters Dovetail Mortise Front

3-056-X und 4-056-X

Parameter	Min/Max	Presetting	Description
P01	+/- 99999	0	Distance from beam start to the reference point
P02	0/50000	WRS/2	Distance from the reference edge to the reference point
P03	0/50000	0	Displacement to the front side
P05	0/1	0	0=with elongation; 1=with pocket
P06	1/179	90	Angle between cut edge and reference edge
P07	1/179	90	Inclination between face and reference side
P08	1/179	90	Angle between axis of the tenon and reference side
P09	0/1000	0	Middle flattening
P10	0/30	0	Angle of cone
P11	1/1000	28	Mortise depth
P12	0/1000	45	Diameter of the curve
P14	+/- 1000	0	Margin on the reference side
P15	+/- 1000	0	Margin opposite the reference side

1.28 Marking / Labeling 3-060-X and 4-060-X

4-060-X

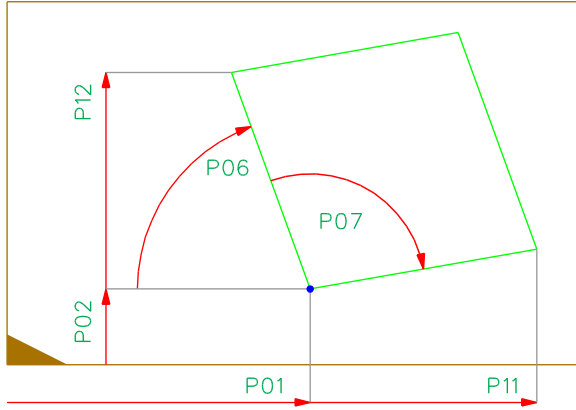

P07=0

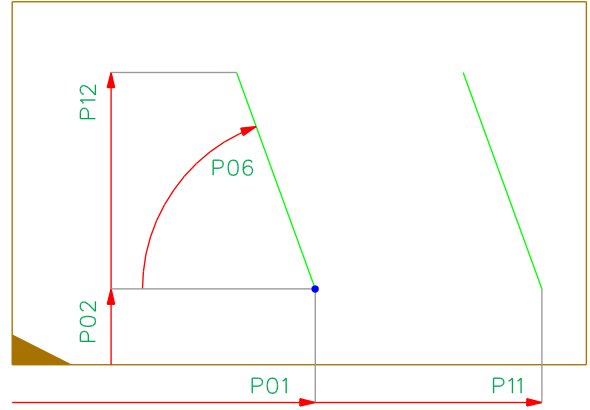



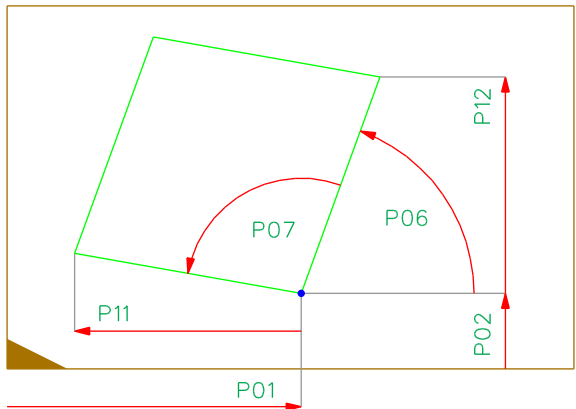

3-060-X

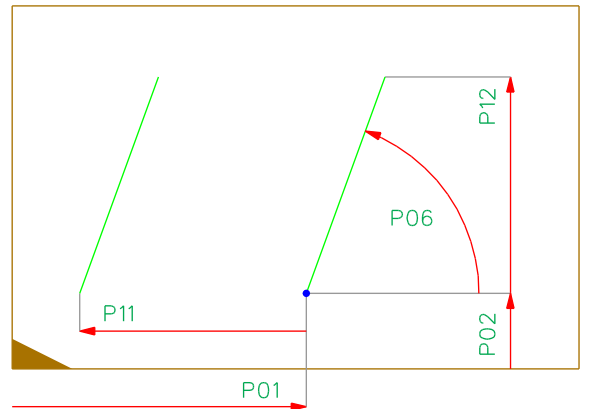

P07=0

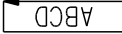

P04:

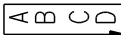
Bit	0	1
0	Marking	No marking
1		Text at reference edge
2		Text in the middle
3		Text opposite to reference edge
4		Text on the left side of marking
5		Text between marking
6		Text on the right side of marking
7		standard 
8		turned to right 
9		upside down 
10		turned to left 
11	Letters standard 	Letters vertically placed 

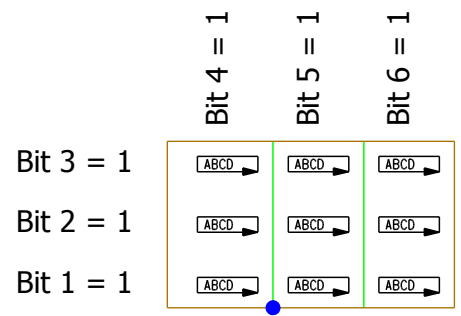

ABCD 

The text is not aligned to the edges defined by P06 / P07.
It is aligned to these edges:

Bit 7 or 9 = 1

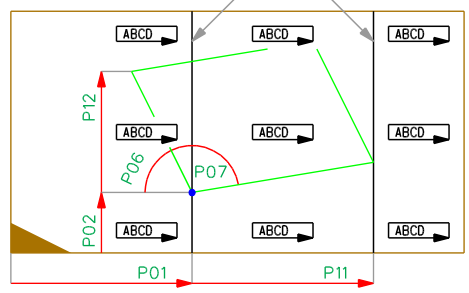

Bit 8 or 10 = 1

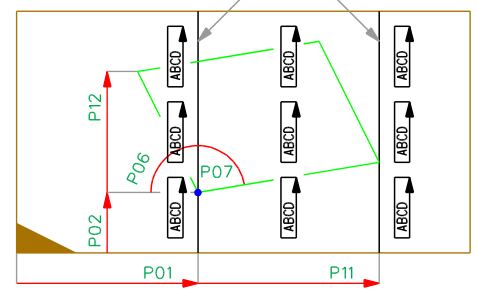

1.28 Parameters Marking / Labeling

3-060-X und 4-060-X

Parameter	Min/Max	Presetting	Description
P01	+/- 99999	0	Distance from beam start to the reference point
P02	+/- 50000	0	Distance from the reference edge to the reference point
P04	0/4095	146	Position and alignment of the text
P06	1/179	90	Angle between axis and reference edge
P07	0/179	90	Interior angle If P07 equals zero, 2 single markings have to be produced
P11	0/50000	100	Width of quadrangle If P11 equals zero, there is only a single marking
P12	0/50000	0	Height of quadrangle If P12 equals zero, marking is limited by the edge opposite to the reference edge
P13	0/50000	200	Height of text If P13 equals zero, the machine determines the text height.
P15		""	Text (String max. 256 characters) Example: P15:"Rafter left"

1.29 Simple Scarf 1-070-X and 2-070-X

2-070-X

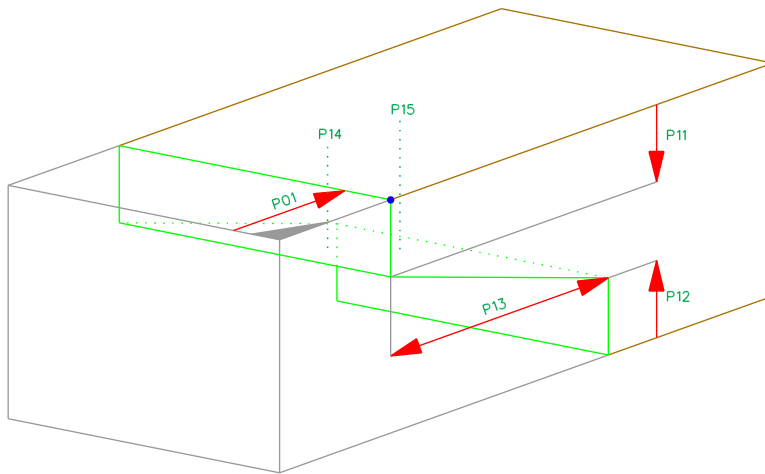

1-070-X

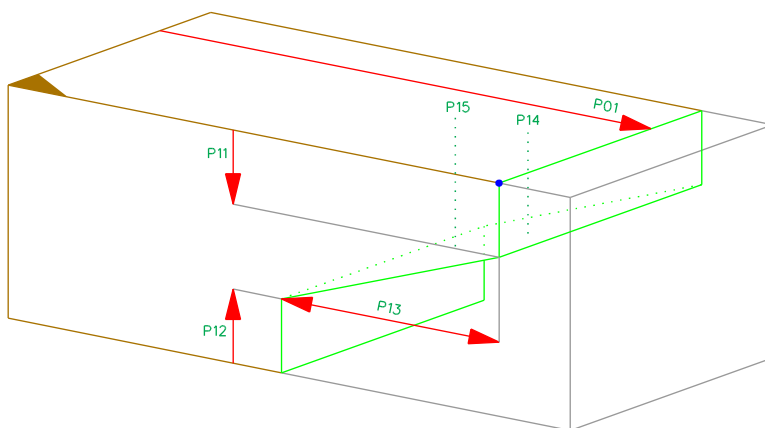

1.29 Parameters Simple Scarf

1-070-X and 2-070-X

Parameter	Min/Max	Presetting	Description
P01	+/- 50000	0	Distance from beam start to the reference point
P11	0/50000	20	Depth at the reference side
P12	0/50000	20	Depth at the opposite of reference side
P13	1/50000	200	Length of the overlap
P14	0/1000	0	Drilling 1 diameter P15=0: This drilling is placed at 1/2 P13 P15>0: This drilling is placed at 1/3 P13
P15	0/1000	0	Drilling 2 diameter Placed at 2/3 P13

1.30 Scarf Joint 1-071-X and 2-071-X

2-071-X

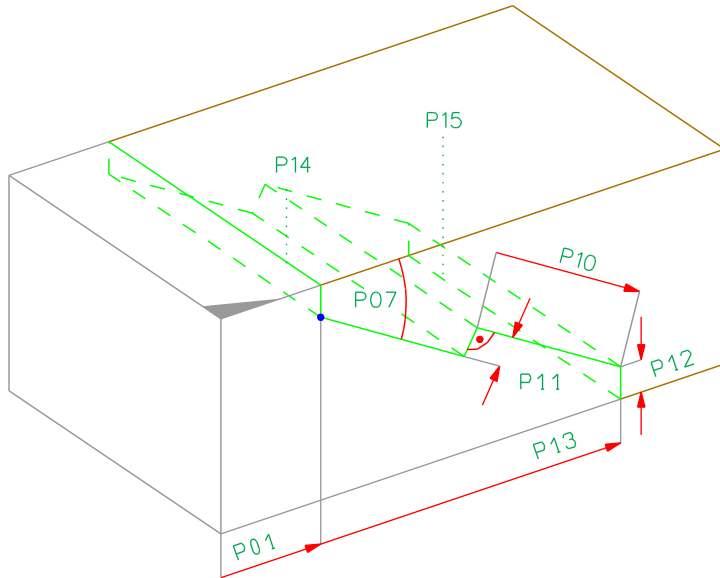

P09 = 0

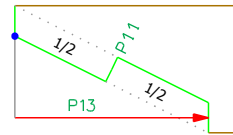

P09 = 1

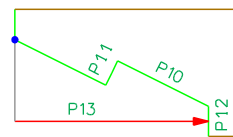

P09 = -1

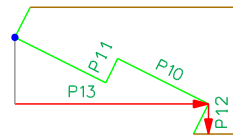

1-071-X

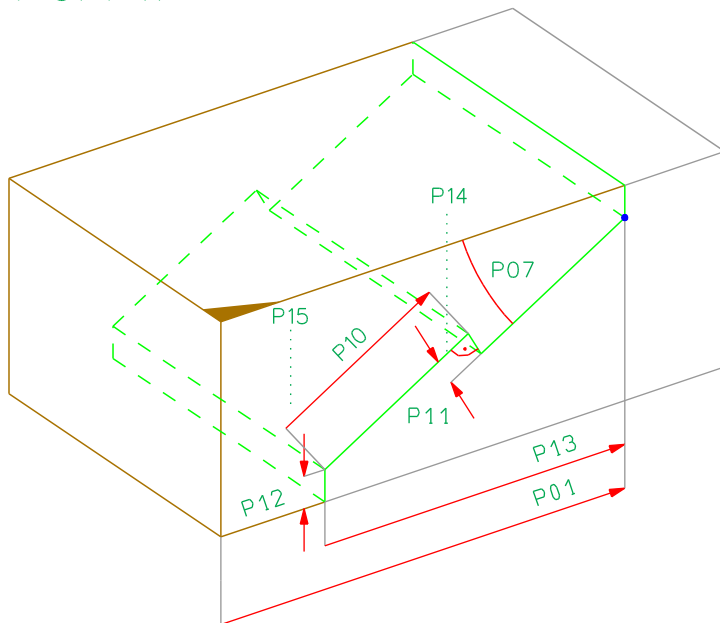

P09 = 0

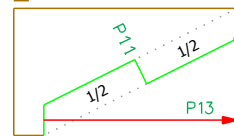

P09 = 1

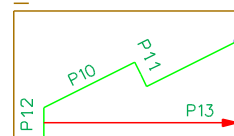

P09 = -1

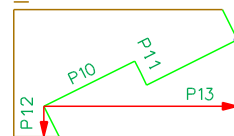

1.30 Parameters Scarf Joint

1-071-X and 2-071-X

Parameter	Min/Max	Presetting	Description
P01	+/- 99999	0	Distance from beam start to the reference point
P07	0/90	0	Angle of inclination of the lapped scarf base
P09	-1/1	1	Shape of the lapped scarf or classic data identification: 1: when cutting orthogonal to reference side -1: when cutting orthogonal to base side 0: classic definition, P10 and P12 are not used
P10	0/50000	0	Length of the lapped scarf base
P11	1/50000	20	Depth of the lapped scarf base
P12	0/50000	0	Depth of the lapped scarf base orthogonal to reference side
P13	1/50000	200	Length
P14	0/1000	0	Drilling 1 diameter P15=0: This drilling is placed at 1/2 P13 P15>0: This drilling is placed at 1/3 P13
P15	0/1000	0	Drilling 2 diameter Placed at 2/3 P13

1.31 Step Joint 1-080-X and 2-080-X

2-080-X

1-080-X

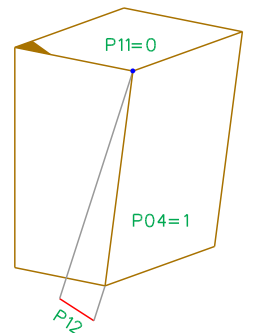
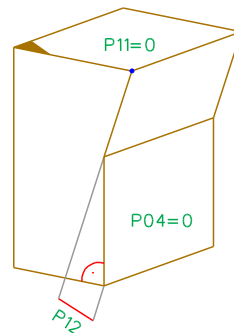
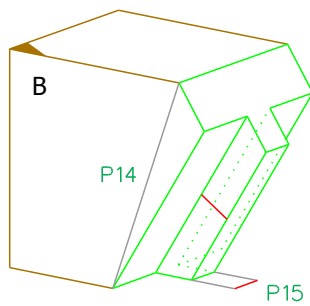
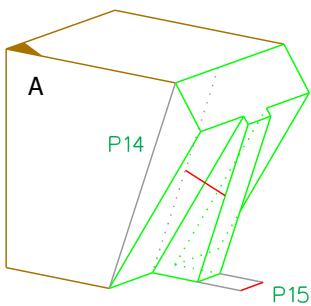
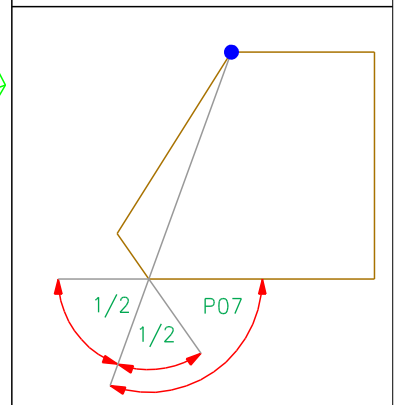
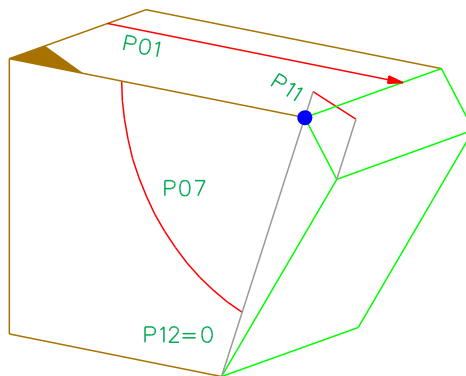
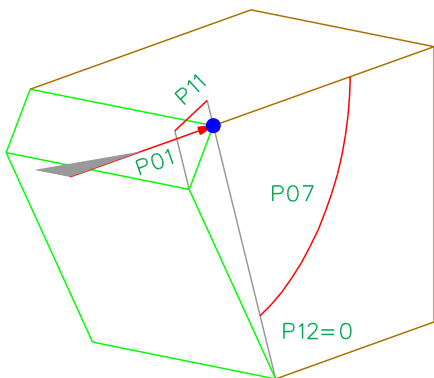
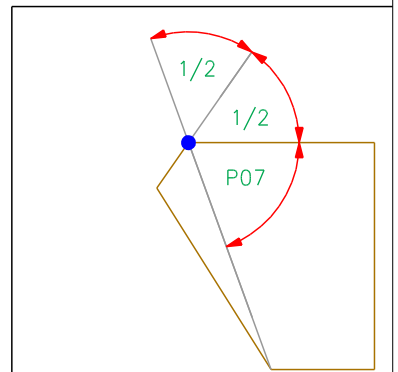
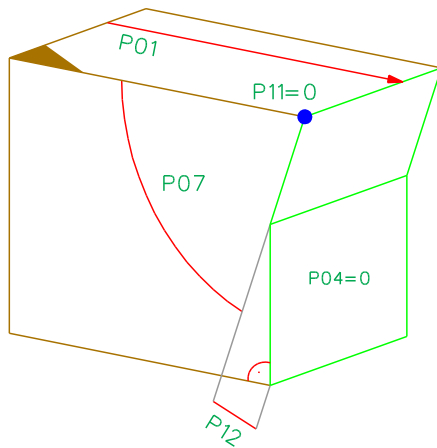
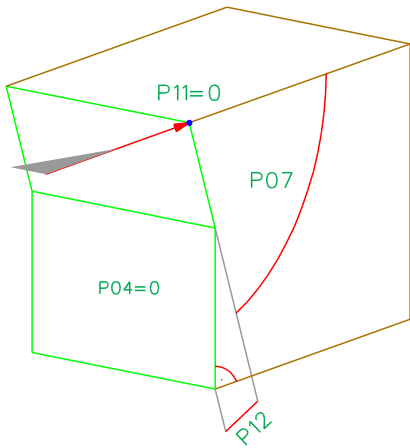
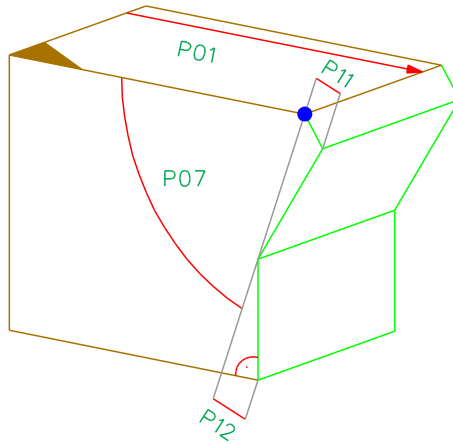
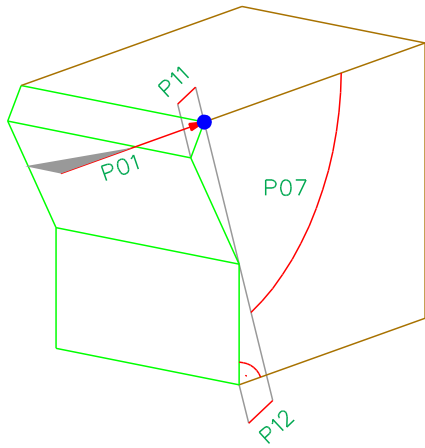

1.31 Parameters Step Joint

1-080-X and 2-080-X

Parameter	Min/Max	Presetting	Description
P01	+/- 99999	0	Distance from beam start to the reference point
P04	0/1	0	Type of heel notch: 0=normal; 1=tapered
P07	1/179	45	Inclination strut
P11	0/1000	20	Depth step joint
P12	0/1000	20	Depth heel notch
P14	0/1000	0	Height tenon Which implementation (A or B) is used depends on the machine
P15	0/1000	0	Width tenon

1.32 Step Joint Notch 3-080-X and 4-080-X

4-080-X

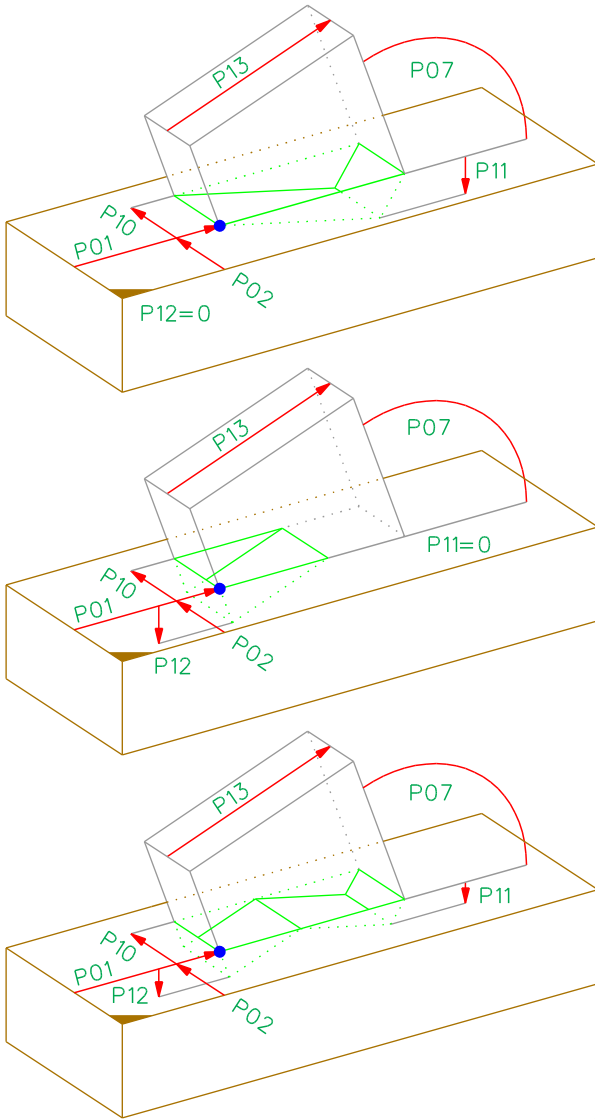

3-080-X

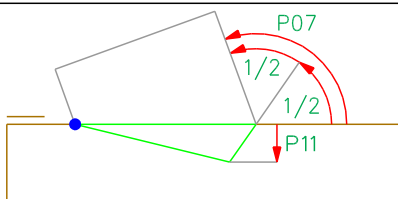
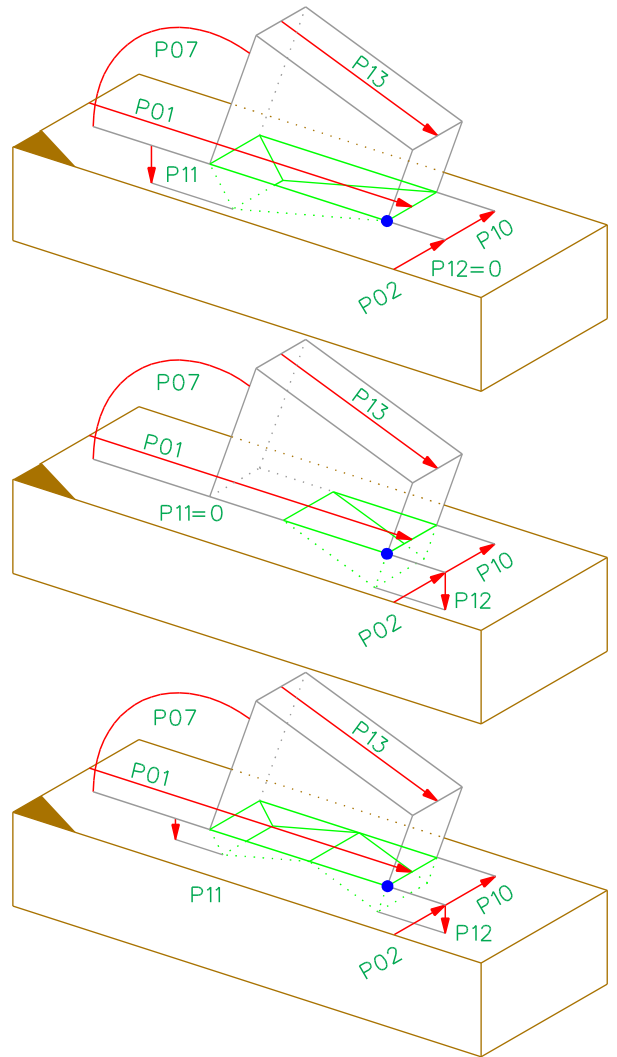

$P07 > 90^\circ$

$P11 > 0$
 $P12 = 0$

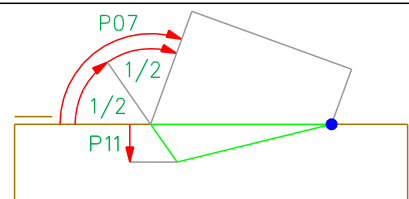

$P07 > 90^\circ$

$P11 = 0$
 $P12 > 0$

$P04 = 0$

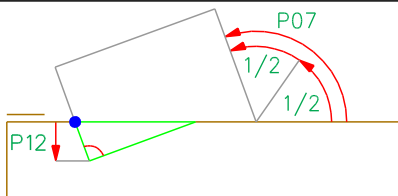

$P07 > 90^\circ$

$P11 = 0$
 $P12 > 0$

$P04 = 1$

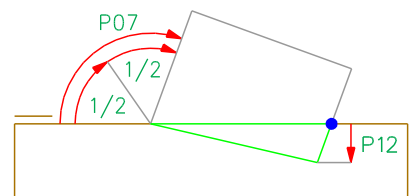
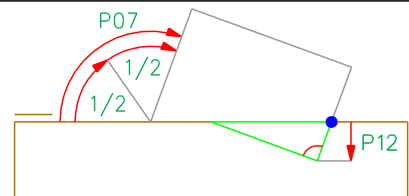

4-080-X		3-080-X
	$P07 < 90^\circ$ $P11 > 0$ $P12 = 0$	
	$P07 < 90^\circ$ $P11 = 0$ $P12 > 0$ $P04 = 0$	
	$P07 < 90^\circ$ $P11 = 0$ $P12 > 0$ $P04 = 1$	

1.32 Parameters Step Joint Notch

3-080-X and 4-080-X

Parameter	Min/Max	Presetting	Description
P01	+/- 99999	0	Distance from beam start to the reference point
P02	0/50000	0	Distance from the reference edge to the reference point
P04	0/1	0	Type of heel notch: 0=normal; 1=tapered
P07	1/179	45	Inclination between strut and reference side
P10	0/50000	WRS	Width of the notch
P11	0/1000	20	Depth step joint
P12	0/1000	20	Depth heel notch
P13	1/50000	200	Height of strut
P14	0/1000	0	Depth of mortise Which implementation (A or B) is used depends on the machine
P15	0/1000	0	Width of mortise

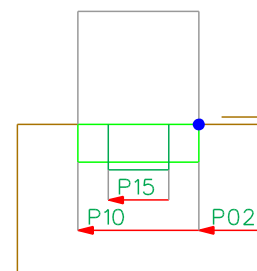
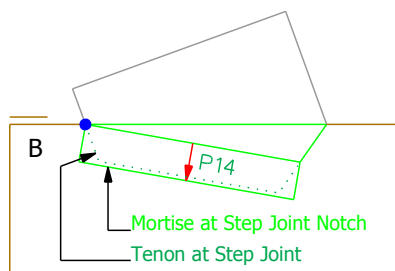
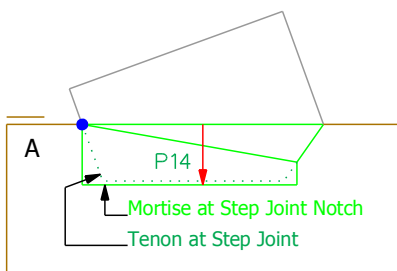

1.33 Planing 3-090-X and 4-090-X

4-090-X

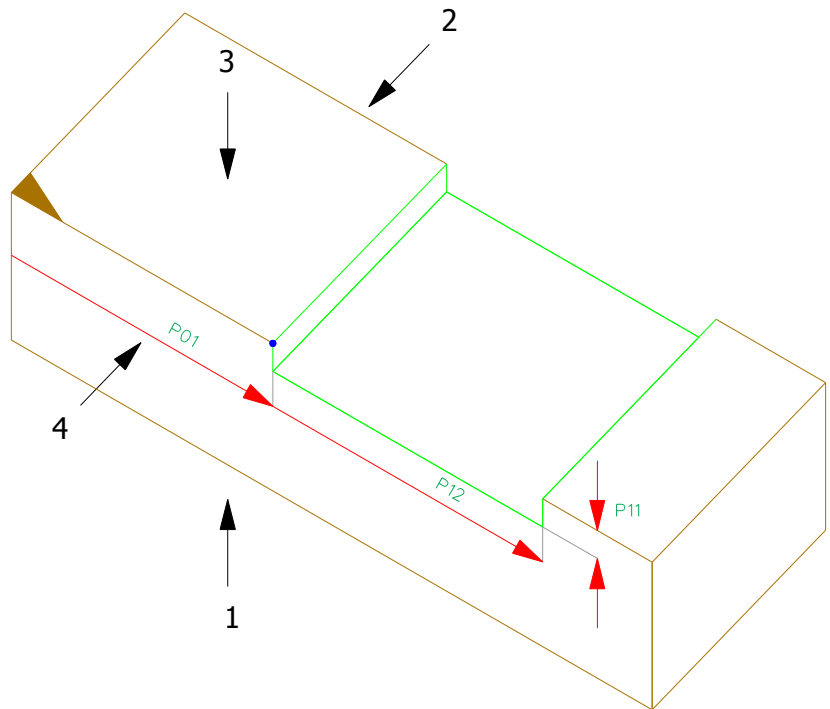

P04 = binary code

	2^0	2^1	2^2	2^3
Binary	1	2	4	8
Reference side	1	2	3	4

Examples

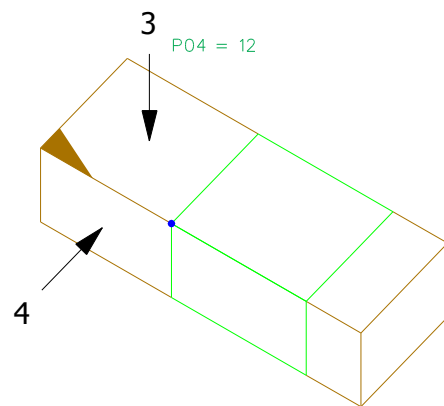
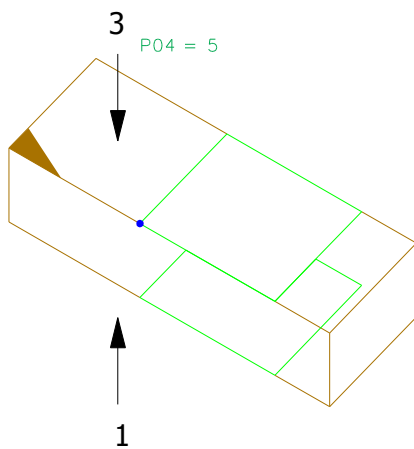

1.33 Parameters Planing

3-090-X and 4-090-X

Parameter	Min/Max	Presetting	Description
P01	+/- 99999	0	Distance from beam start to the reference point
P04	1/15	15	Specification of side(s) to be planed; binary coded
P11	0/50	1	Planing depth
P12	+/- 99999	LRS	Length of the area to be planed

1.34 Profile Front 3-100-X and 4-100-X

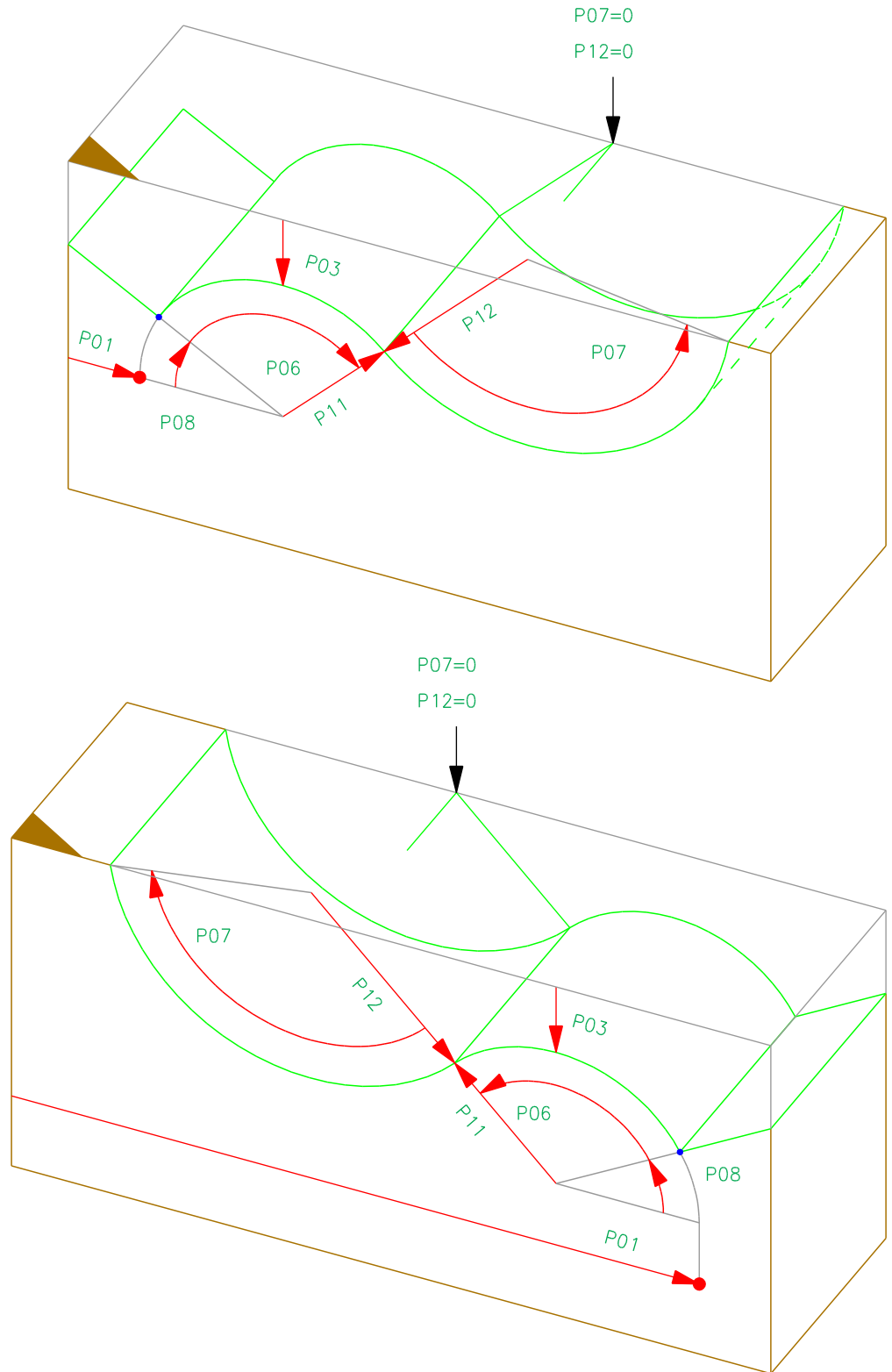

1.34 Parameters Profile Front

3-100-X and 4-100-X

Parameter	Min/Max	Presetting	Description
P01	+/- 99999	0	Distance from beam start to the reference point
P03	+/- 1000	0	Distance from the reference edge to the reference point
P06	0/180	90	Rotation angle of the first curve of the profile
P07	0/180	90	Rotation angle of the profile towards the reference edge
P08	+/- 180	0	Offset angle
P11	+/- 1000	250	Radius of the first curve
P12	+/- 1000	250	Radius of the second curve

1.35 Profile Head concave 3-101-X and 4-101-X

4-101-X

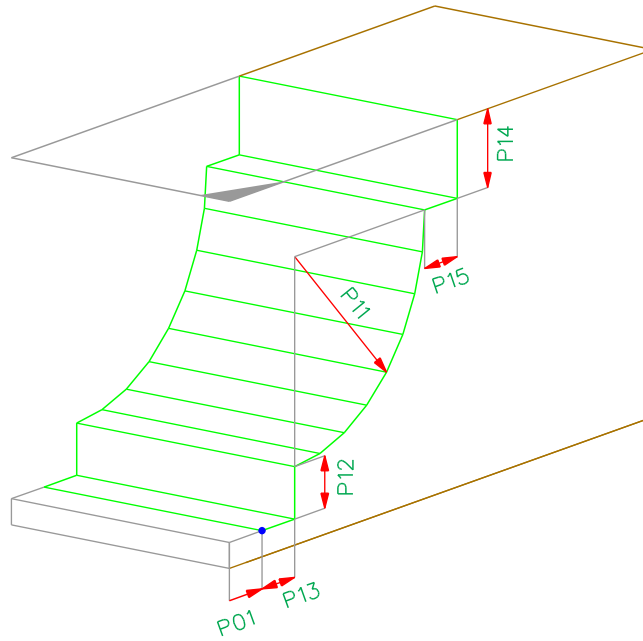

3-101-X

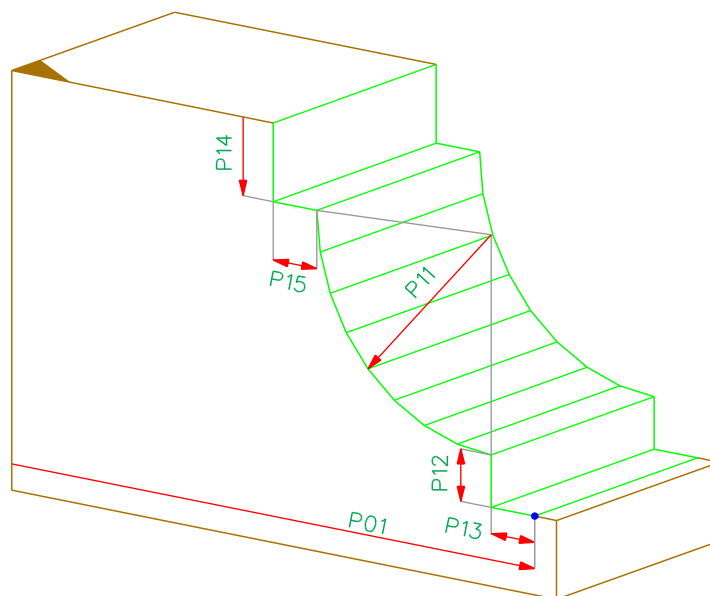

1.35 Parameters Profile Head concave

3-101-X und 4-101-X

Parameter	Min/Max	Presetting	Description
P01	+/- 99999	0	Distance from beam start to the reference point
P11	0/1000	120	Radius
P12	+/- 1000	20	Depth
P13	0/1000	20	Displacement
P14	+/- 1000	20	Depth
P15	0/1000	20	Displacement

1.36 Profile Head convex 3-102-X and 4-102-X

4 - 102 - X

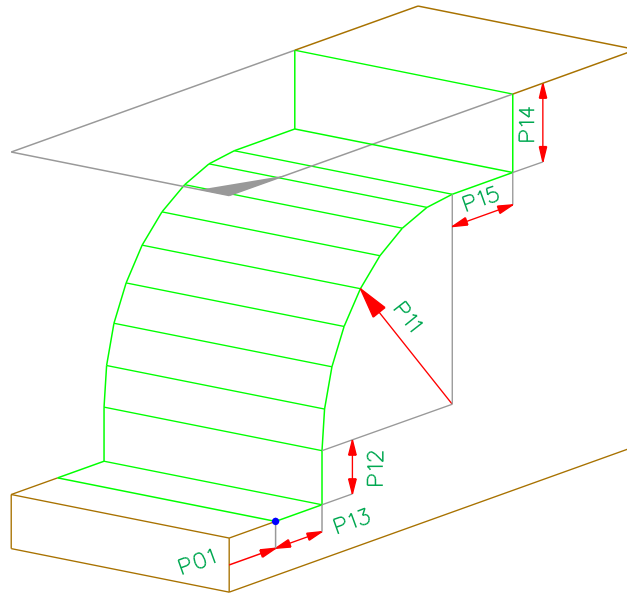

3 - 102 - X

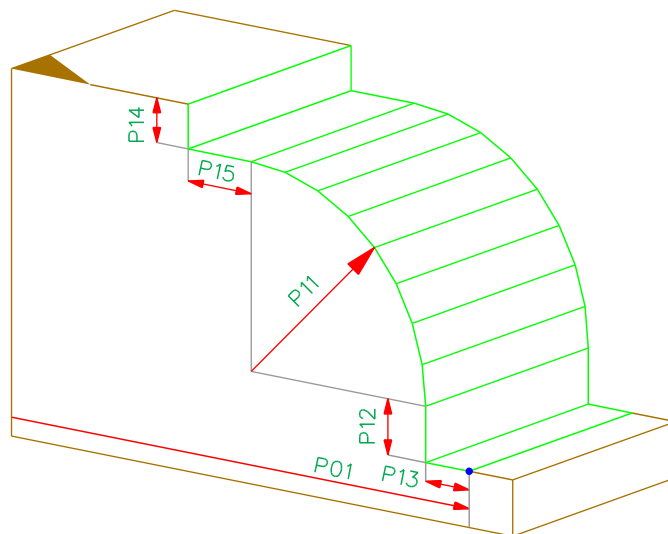

1.36 Parameters Profile Head convex

3-102-X und 4-102-X

Parameter	Min/Max	Presetting	Description
P01	+/- 99999	0	Distance from beam start to the reference point
P11	0/1000	120	Radius
P12	+/- 1000	20	Depth
P13	0/1000	20	Displacement
P14	+/- 1000	20	Depth
P15	0/1000	20	Displacement

1.37 Profile Head cambered 3-103-X and 4-103-X

4-103-X

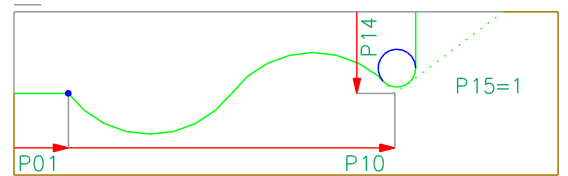
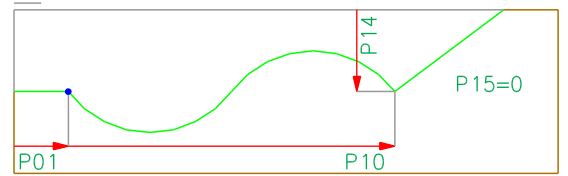
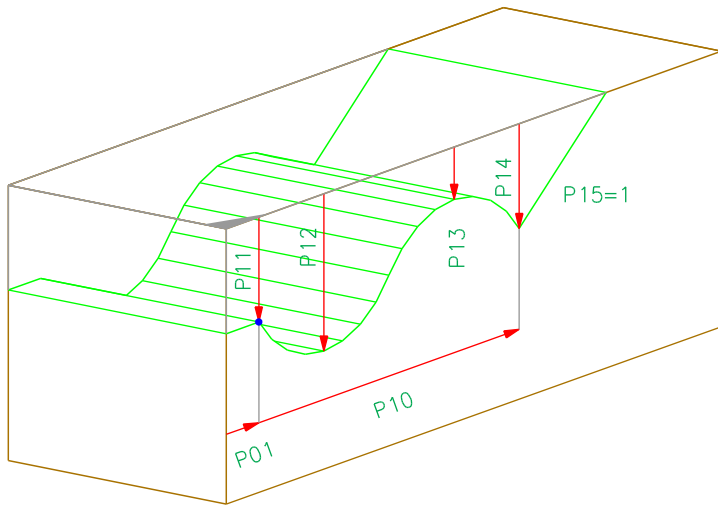

3-103-X

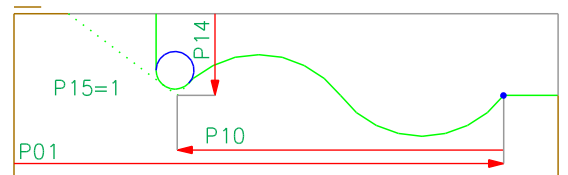
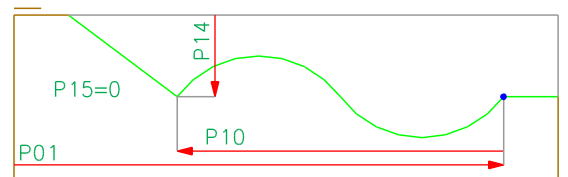
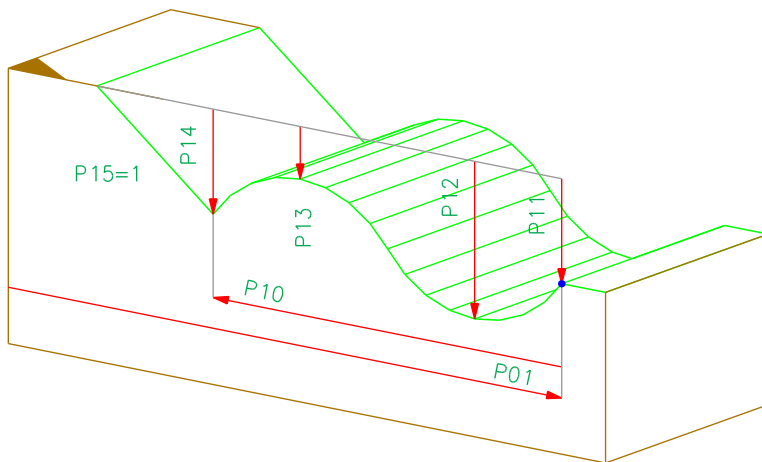

The curve is defined by a cubic polynomial.

$$Y = Ax^3 + Bx^2 + Cx + D$$

The coefficients A, B, C and D must be calculated on the machine side.

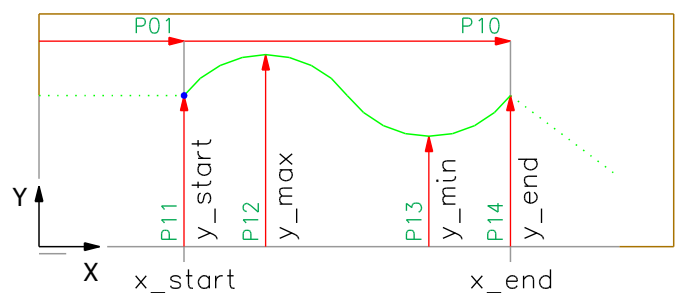

1.37 Parameters Profile Head cambered

3-103-X and 4-103-X

Parameter	Min/Max	Presetting	Description
P01	+/- 99999	0	Distance from beam start to the reference point
P10	0/50000	500	Profile length
P11	+/- 1000	40	Depth at the reference point
P12	+/- 1000	60	Maximum depth of profile
P13	+/- 1000	10	Minimum depth of profile
P14	+/- 1000	40	Depth at the profile end
P15	0/1	1	Premill: 0=round; 1=angular

1.38 Round Arch 4-104-X

4 - 104 - X

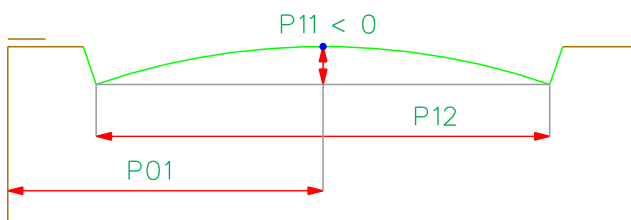
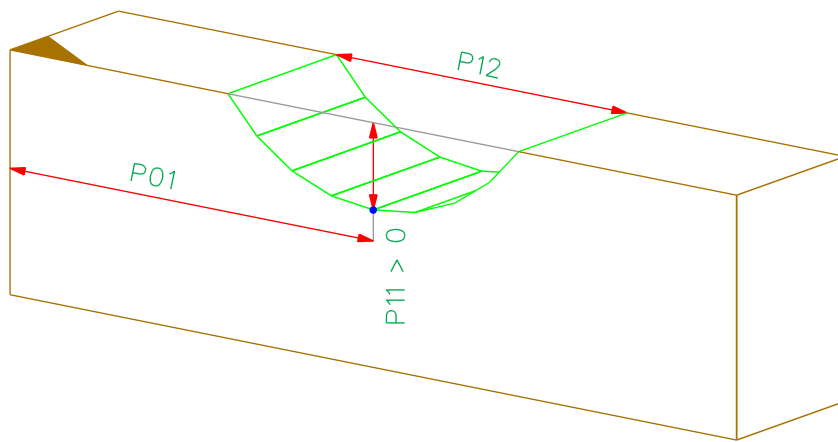

1.38 Parameters Round Arch

4-104-X

Parameter	Min/Max	Presetting	Description
P01	+/- 99999	0	Distance from beam start to the reference point
P11	+/- 1000	30	Depth of the arch segment
P12	0/30000	500	Length of the arch segment

1.39 Triangle Cut 4-120-X

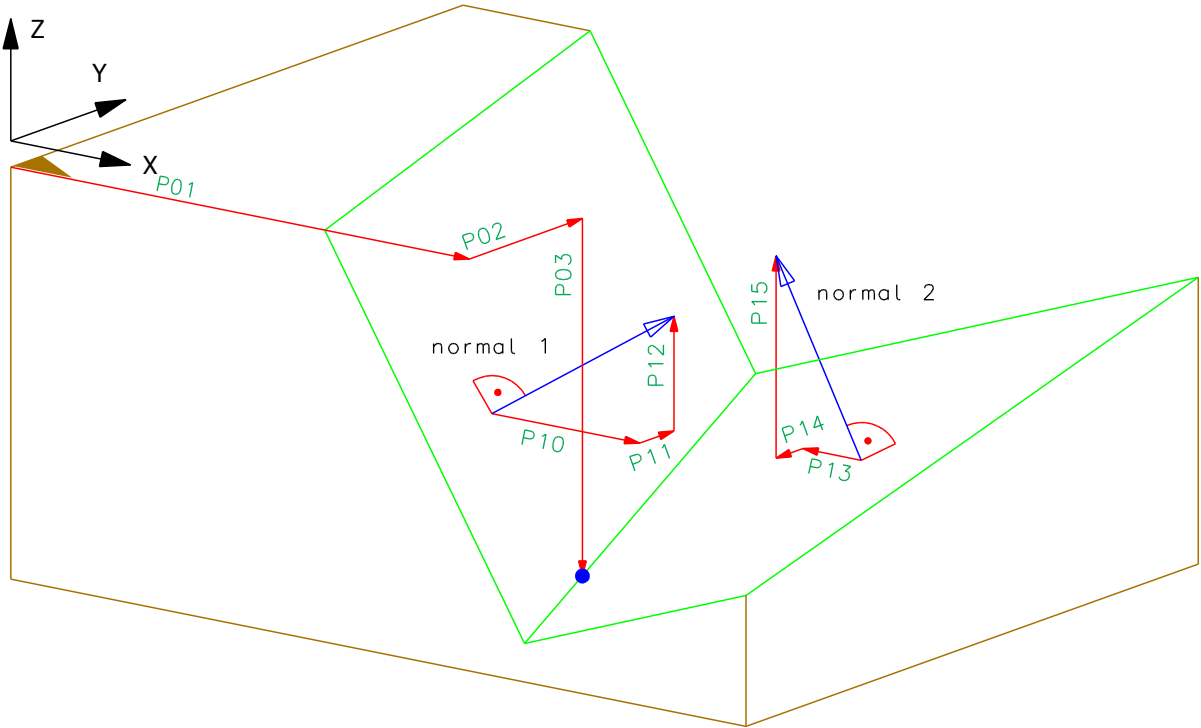

1.39 Parameters Triangle Cut

4-120-X

Parameter	Min/Max	Presetting	Description
P01	+/- 99999	0	Distance from beam start to the reference point
P02	+/- 50000	0	Distance from the reference edge to the reference point
P03	+/- 50000	0	Distance from the reference side to the reference point
P10	+/- 50000	1	Normal vector 1: Length of X-component
P11	+/- 50000	0	Normal vector 1: Length of Y-component
P12	+/- 50000	1	Normal vector 1: Length of Z-component
P13	+/- 50000	-1	Normal vector 2: Length of X-component
P14	+/- 50000	0	Normal vector 2: Length of Y-component
P15	+/- 50000	1	Normal vector 2: Length of Z-component

1.40 Dovetail 1/2/3/4-138-X

2/4-138-X

	P04=1	P04=0
P14=0		
P14=1		
P05	<p>P05=0</p>	<p>P05=0</p>
	<p>P05=-1</p>	<p>P05=-1</p>
	<p>P05>0</p>	<p>P05>0</p>

1.40 Dovetail 1/2/3/4-138-X

1/3-138-X

	P04=1	P04=0
P14=0		
P14=1		
P05	<p>P05=0</p> <p>P05=-1</p> <p>P05>0</p>	<p>P05=0</p> <p>P05=-1</p> <p>P05>0</p>

1.40 Dovetail

1/2/3/4-138-X

Parameter	Min/Max	Presetting	Description
P01	+/- 99999	0	Distance from beam start to the reference point
P02	0/50000	30	Distance between "inside" an side of part
P03	+/- 50000	HRS/2	Distance orthogonal to the reference side
P04	0/1	0	0: "inside" at reference edge, 1: "inside" at opposite of reference edge
P05	-1/0/50000	0	0: Without rebate or mitre -1: With mitre >0: With rebate
P09	0/45	15	Inclination
P11	0/50000	0.333 x HRS	Depth 1
P12	0/50000	0.167 x HRS	Depth 2
P14	0/1	0	0: European Dovetail 1: American Dovetail
P15	0/50000	WRS	Length
P16			0: Processing on the reference side and opposite the reference side 1: Processing only on the reference side 2: Processing only opposite the reference side

P16=0

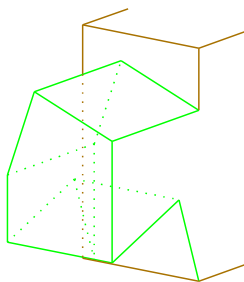

P16=1

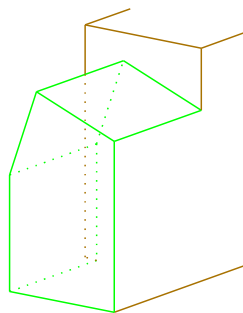

P16=2

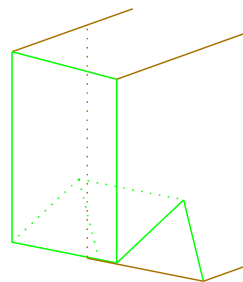

1.41 Free Contour 0-250-X, 3-250-X, 4-250-X

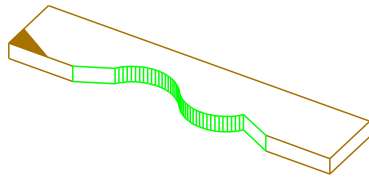

3-250-X Toolpath to the left of the contour

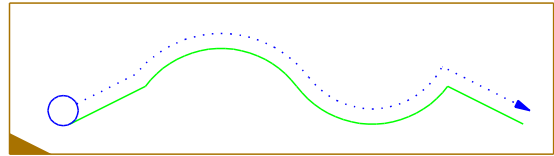

0-250-X Toolpath on contour

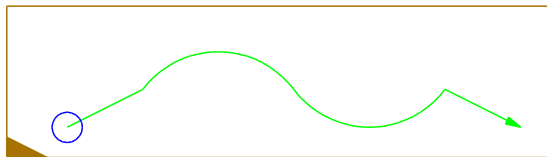

4-250-X Toolpath to the right of the contour

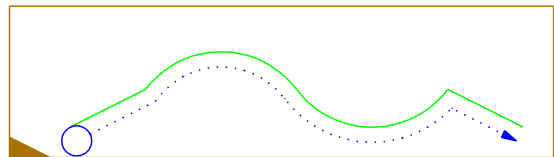

example

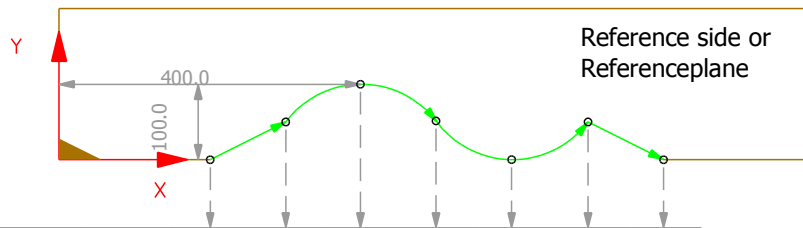

4-250-X

PROCESSIDENT		1	2	3	4	5	
Typ	P08	0	1	2	2	1	
Next Segment	P09	2	3	4	5	0	
Endpoint	X	P01	200.0	300.0	500.0	700.0	800.0
	Y	P02	0.0	50.0	50.0	50.0	0.0
	Z	P03	0.0	0.0	0.0	0.0	0.0
Point on arc	X	P10			400.0	600.0	
	Y	P11			100.0	0.0	
	Z	P12			0.0	0.0	

Inclination P06

In this view the contour is oriented away from the observer.

3-250-X

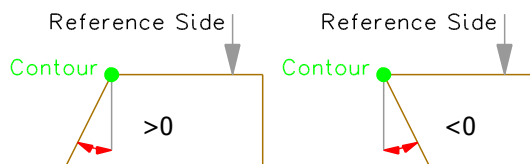

4-250-X

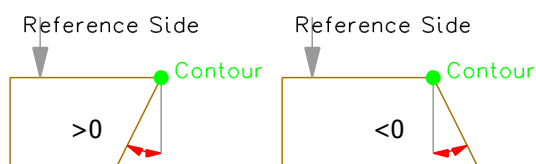

1.41 Parameters Free Contour

0-250-X, 3-250-X, 4-250-X

Segment typ	Startpoint P08=0	Startpoint P08=100	Startpoint P08=101	Straight Line P08=1	Arc P08=2
P01 P02 P03	Start-point x y z	Start-point x y z	Start-point x y z	End-point x y z	End-point x y z
P05	Depth (≥ 0) 0: complet HRS				
P06	Inclination	Processident of contour 101	Processident of contour 100	Inclination No meaning, if this segment is - part of contour, which has an associated contour or is - part of an associated contour	
P07	Mode: 0=contour only 1=countersink completely. Only for closed contours.				
P08	Segmenttyp: 0=Startpoint 100=Startpoint. There is an associated contour existing. 1=Straight line 101=Startpoint. This is an associated contour. 2=Arc				
P09	Processident of following segment. 0 means, there is no further segment.				
P10 P11 P12					Point on arc x y z

Depth P03, P05

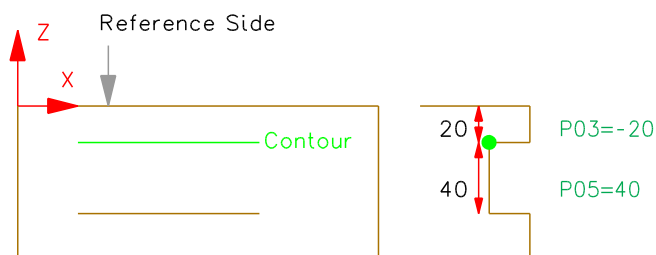

Circle

The circle must be defined with 2 arcs a 180 degrees.

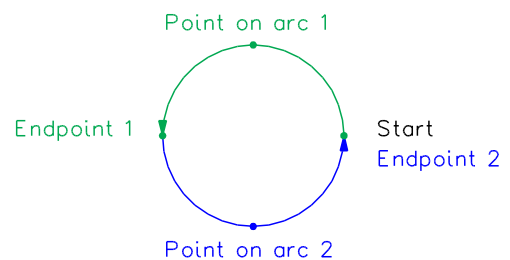

Contour with an associated contour

Upper line: Pt1 to Pt4

Lower line: Pt5 to Pt8 (associated contour)

The contour and its associated contour are defined on the same referenceside.

The contour and the associated contour are connected via the processidents of their respective starting points. The parameter P06 of the starting point of the contour (P08=100) references the associated contour, whereas the parameter P06 of the starting point of the associated contour (P08=101) references the contour.

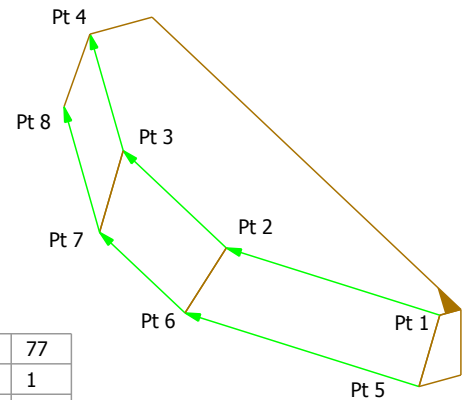

PROCESSIDENT		70	71	72	73	74	75	76	77
Typ	P08	100	1	1	1	101	1	1	1
Next Segment	P09	71	72	73	0	75	76	77	0
Associated contour	P06	74	--	--	--	70	--	--	--
Endpoint	P01/P02/P03	Pt 1	Pt 2	Pt 3	Pt 4	Pt 5	Pt 6	Pt 7	Pt 8

1.42 Variant 0-900-X, 1-900-X, 2-900-X, 3-900-X, 4-900-X

With this type the user can define his own processings. In addition to the parameters of a processing he has to specify the machining by an Integer value in the PROCESSKEY line.

Example:

```
PROCESSKEY: 4-900-2      4711
COMMENT: "MyProcess"
```

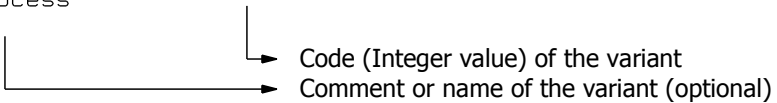

Code (Integer value) of the variant
Comment or name of the variant (optional)

The parameters P01 to P15 can be used to describe the processing.

In order to avoid numbering conflicts and ensure interoperability of variants of different manufacturers, variants should be sent to design2machine. They will then be published on the design2machine homepage and will eventually be defined as a standard processing in a later BTL version.

1.42 Parameters Variant

0-900-X, 1-900-X, 2-900-X, 3-900-X, 4-900-X

Parameter	Min/Max	Presetting	Description
P01	+/- 99999	0	user definded
P02	+/- 99999	0	user definded
P03	+/- 99999	0	user definded
P04	+/- 99999	0	user definded
P05	+/- 99999	0	user definded
P06	+/- 99999	0	user definded
P07	+/- 99999	0	user definded
P08	+/- 99999	0	user definded
P09	+/- 99999	0	user definded
P10	+/- 99999	0	user definded
P11	+/- 99999	0	user definded
P12	+/- 99999	0	user definded
P13	+/- 99999	0	user definded
P14	+/- 99999	0	user definded
P15	+/- 99999	0	user definded