

# ***design2machine***

*BTLx interface description*

*Version: BTLx 1.0*

*Last modified: 16.09.2019*

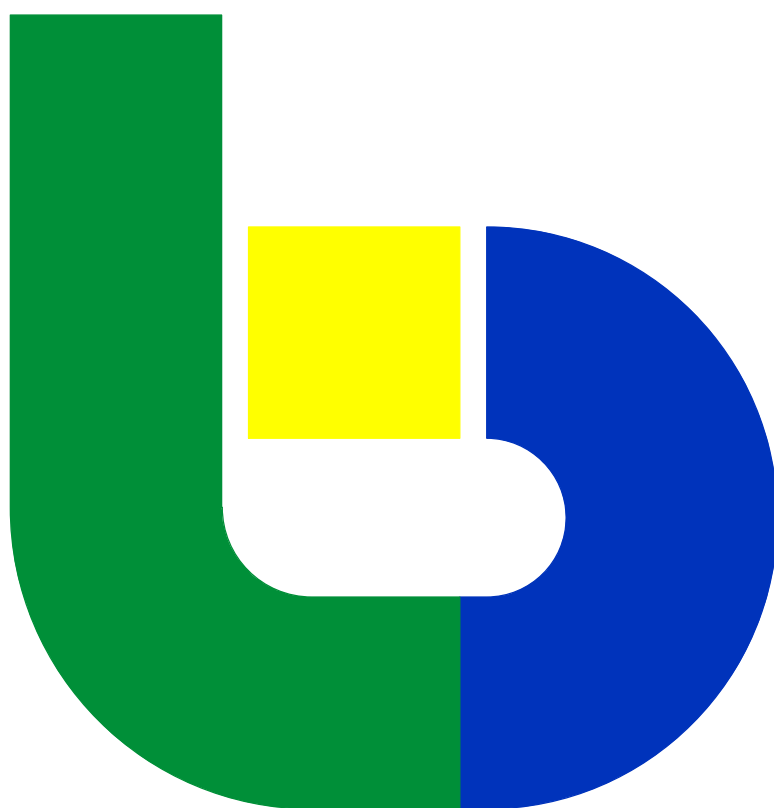

## Common Data Interface for Wood Working Machines

The following interface description is designed for the structured representation of the data relevant to the manufacturing process.

It does not contain any machine specific data. This allows the interface to be used as a common data interface.

If there is a need to prepare the data stored in this interface for some special wood working machine or some special control, then these data should be imported by a suitable CAM system and then properly processed.

This documentation is a graphical appendix to the BTLX schema. You can find this schema at

[http://www.design2machine.com/btlx/btlx\\_10.xsd](http://www.design2machine.com/btlx/btlx_10.xsd)

BTLx files are identified by the ".btlx" file extension.

A BTLx file contains general data related to the project, information about the building elements as well as the relationship between them and parametric descriptions of the processings of each building element.

In order to minimize storage space requirements, the specification defines compressed BTLx files which are identified by the ".btlz" file extension. Such a file has to be a standard zip file and may only contain a single BTLx file.

For more information or questions regarding the BTLx format, please contact:

[www.design2machine.com](http://www.design2machine.com)  
[info@design2machine.com](mailto:info@design2machine.com)

## Content

	Page
History	3
General	4
ReferenceSide	5
ReferencePlane	6
List of processings	8
Description of processings	9
Prefabrication	102

## History

Date	Modification	Build	Page
23.03.2017	Lap: Definition of LeadAngle and LeadInclination	1.0	30, 31
23.03.2017	Birdsmouth: Definition of LeadAngle and LeadInclination	1.0	23, 24
13.06.2017	LongitudinalCut: Changed definiton of ToolPosition	1.0	11
06.11.2018	RidgeValleyCut: StartDepht can also be < 0	1.0	16
16.09.2019	Dovetail: Better description	1.0	58, 59, 60
04.03.2020	SawCut: Changed limit of Angle from 0/+180 to -180/+180	1.0	18

# General

These drawings are a graphical appendix to the description in the XML schema.

## Recess

Recess = automatic

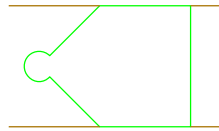

Recess = manual

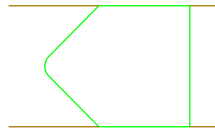

Additional manual work is necessary.

## RawPart

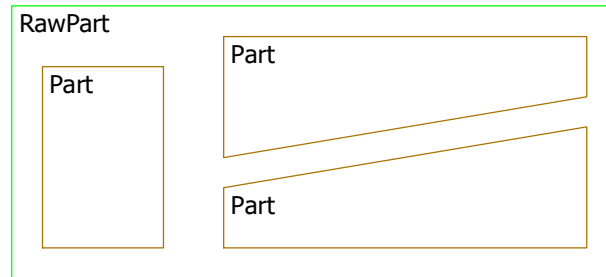

## AligmentType

- LocationType = bottomRail  
 or topRail  
 or bottomRailAngled  
 or topRailAngled  
 or horizontalComponent  
 or verticalComponent  
 or angledComponent

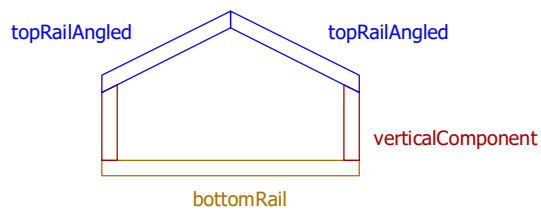
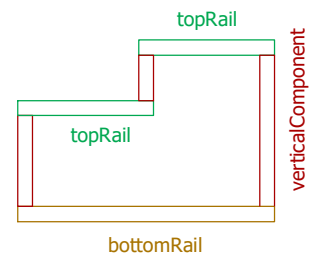
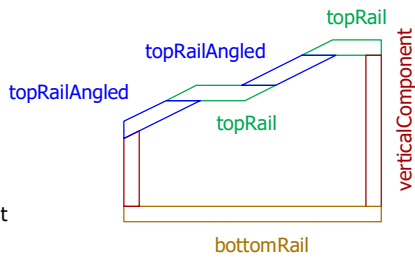

# ReferenceSide

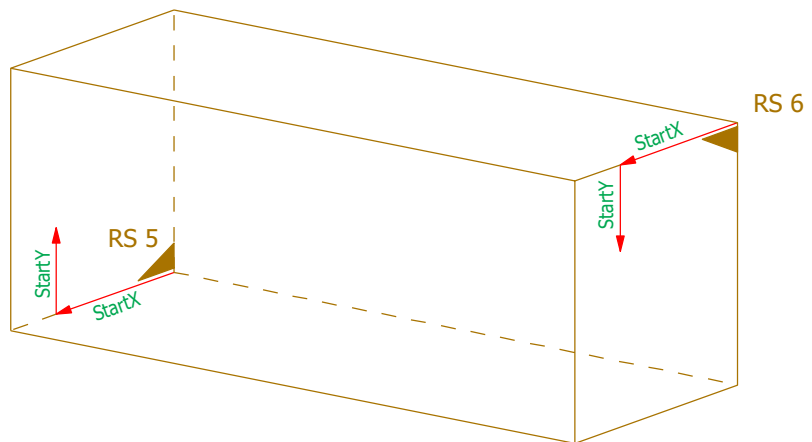
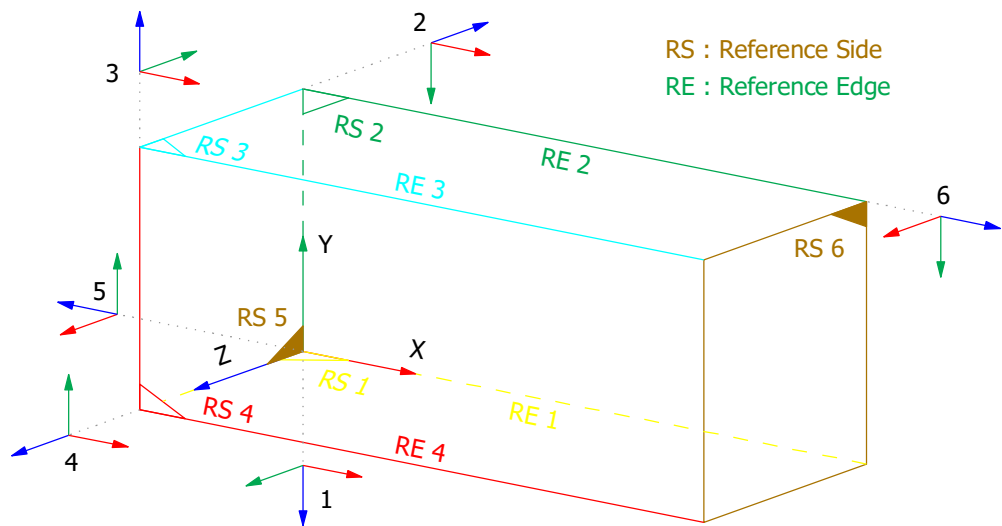
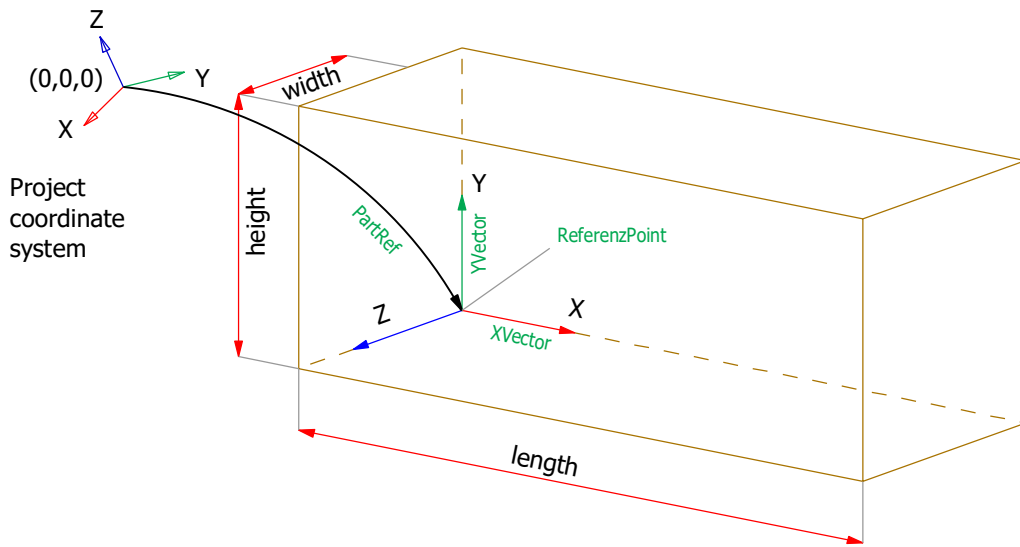

## Referenceplane

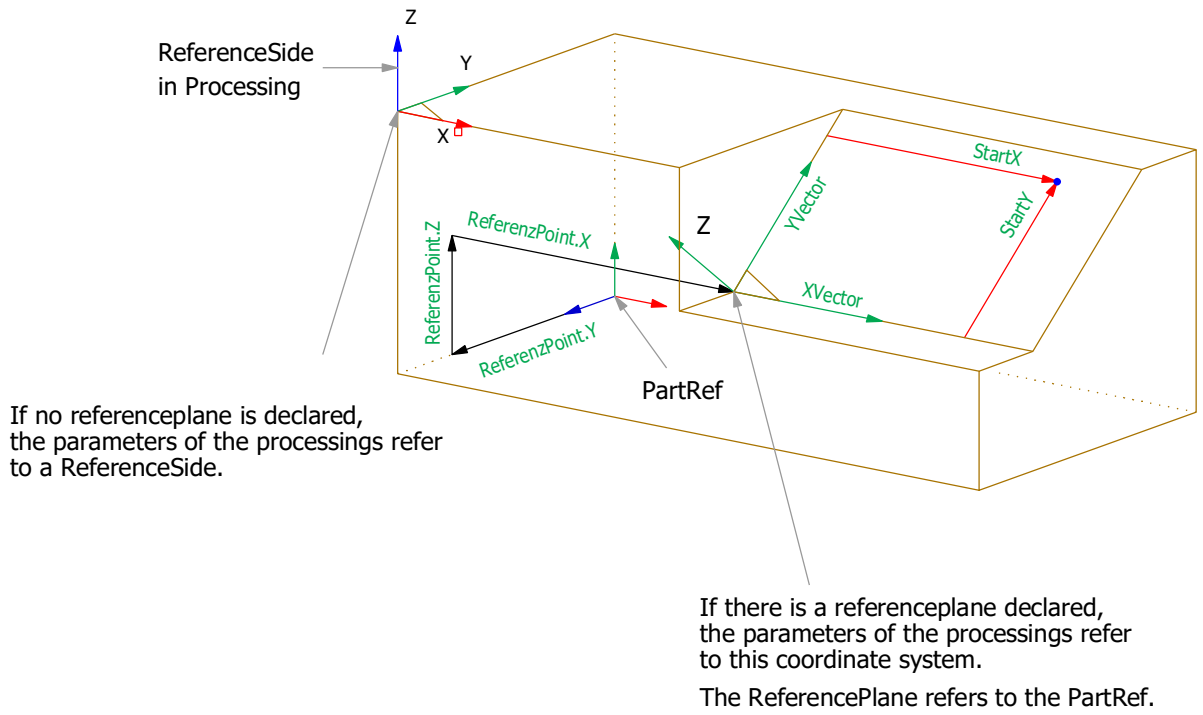

## View

Most of the processings are drawn by a view orthogonal to the reference side. Otherwise the zeropoint of the reference side is displayed with a brown line.

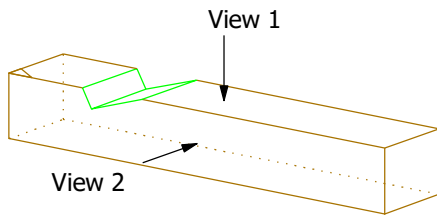

View 1



View 2

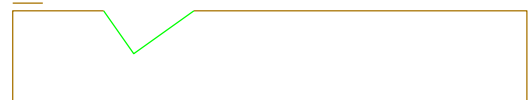

Part in a rawpart, part in composite, composite in composite

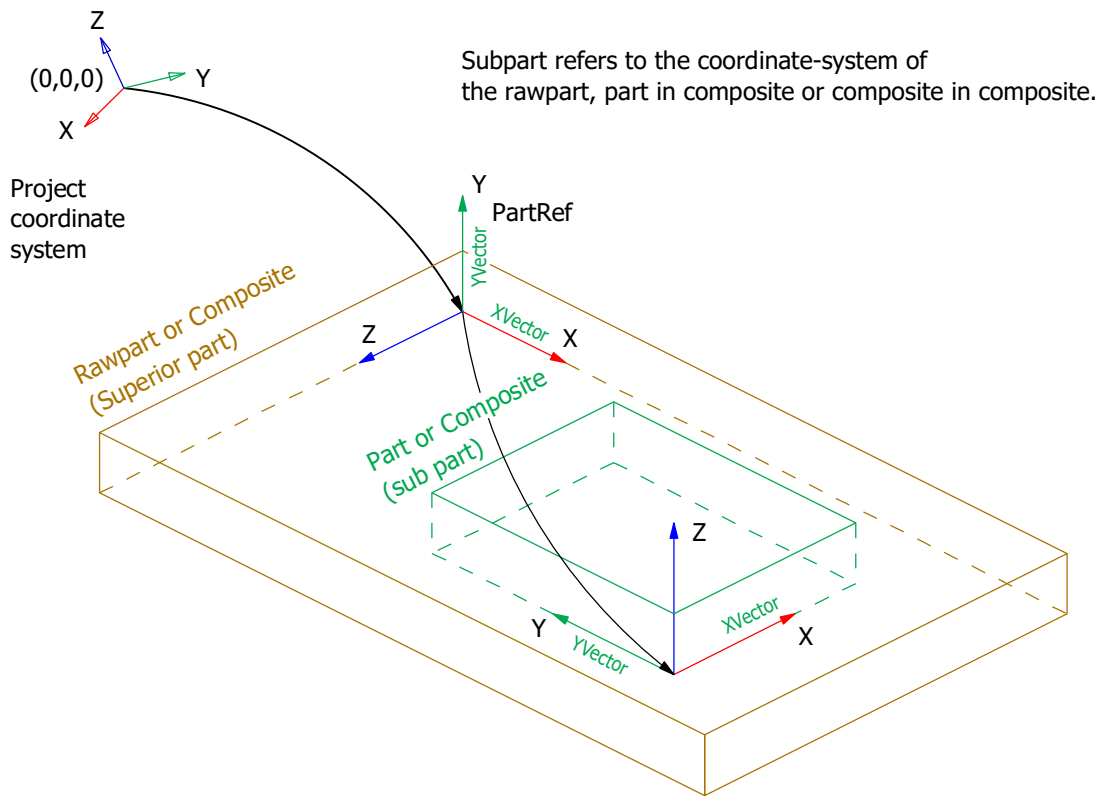

Camber

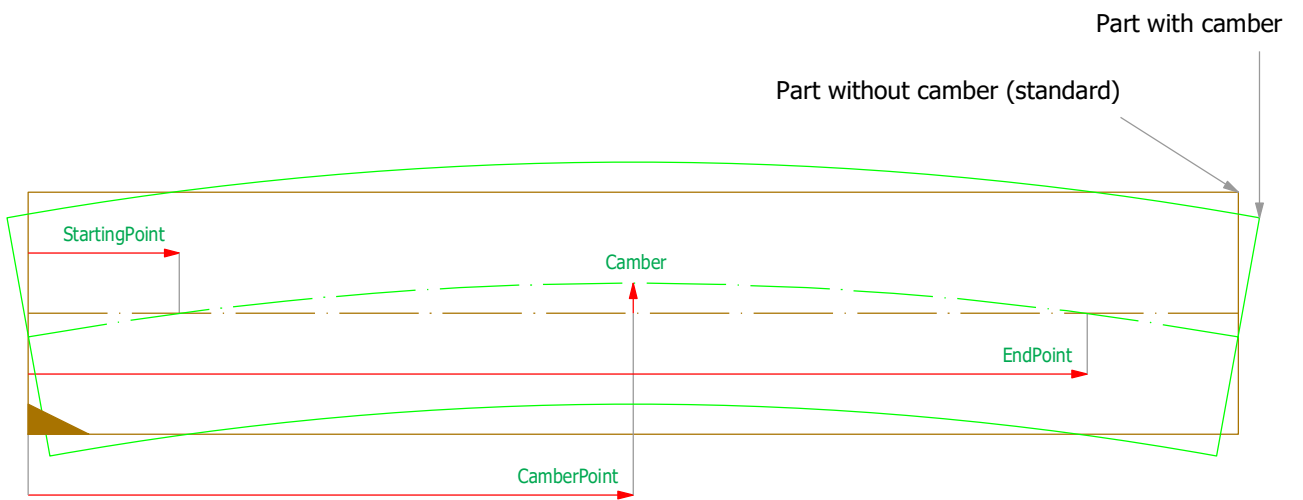

All processings are defined in the part without camber.

## List of Processings

Processing	Page
JackRafterCut	09
LongitudinalCut	11
DoubleCut	13
RidgeValleyCut	15
SawCut	17
Slot	19
BirdsMouth	23
HipValleyRafterNotch	28
Lap	30
LogHouseHalfLap	34
FrenchRidgeLap	36
Chamfer	38
LogHouseJoint	40
LogHouseFront	43
Pocket	45
Drilling	47
Tenon	49
Mortise	51
House	53
HouseMortise	55
DovetailTenon	57
DovetailMortise	59
Marking	61
Text	63
SimpleScarf	65
ScarfJoint	67
StepJoint	69
StepJoint Notch	71
Planing	73
ProfileFront	75
ProfileCambered	77
RoundArch	79
ProfileHead	81
Sphere	83
TriangleCut	85
TyroleanDovetail	87
Dovetail	96
SimpleContour	99
Variant	



### JackRafterCut

Orientation = start

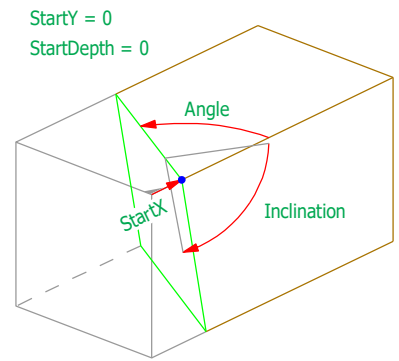
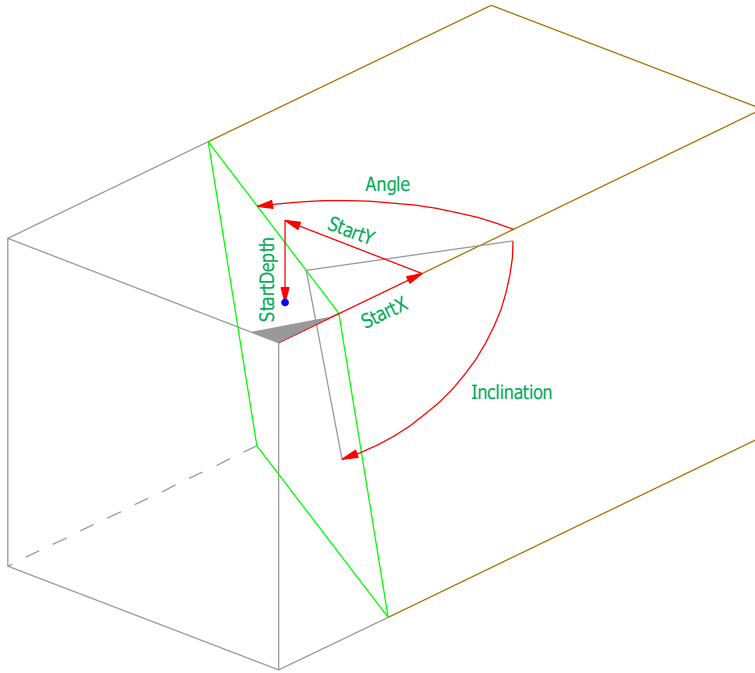

Orientation = end

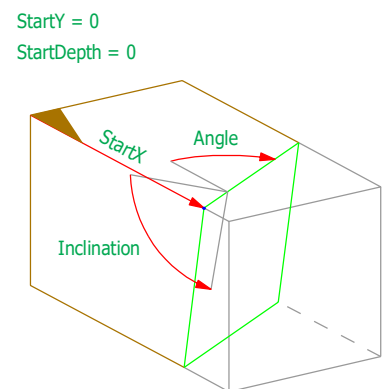
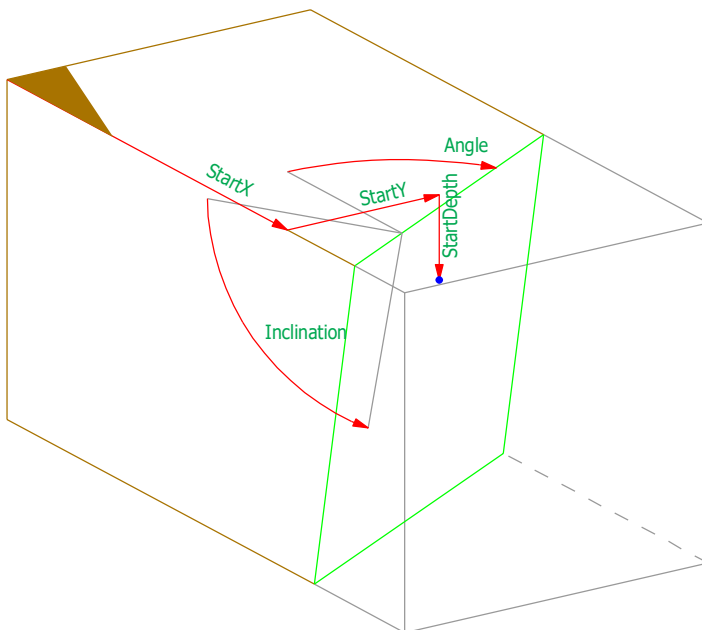

## Parameters JackRafterCut

Name	Type	Default	Min	Max
Orientation	OrientationType		start	end
StartX	LengthPosType	0.0	-100000.0	100000.0
StartY	WidthType	0.0	0.0	50000.0
StartDepth	WidthType	0.0	0.0	50000.0
Angle	AngleType	90.0	0.1	179.9
Inclination	AngleType	90.0	0.1	179.9

### LongitudinalCut

Inclination > 0

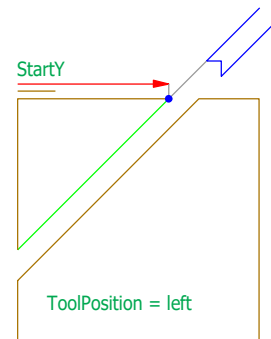
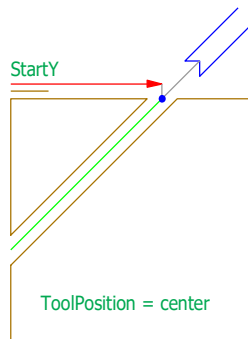
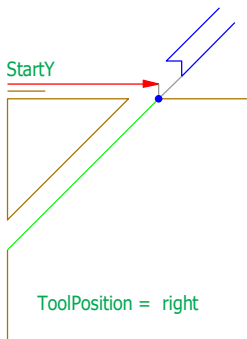
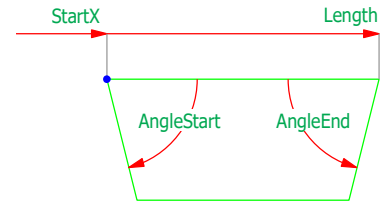
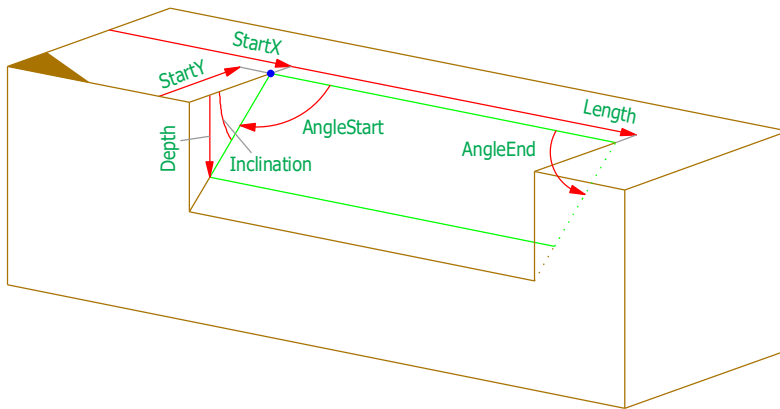

Inclination < 0

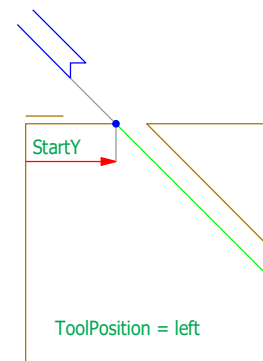
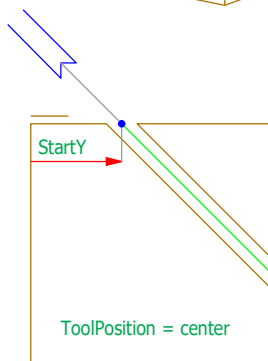
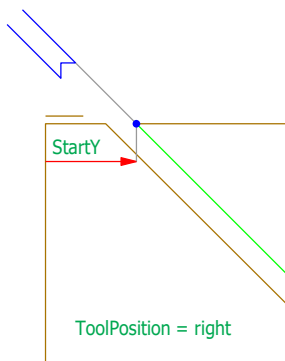
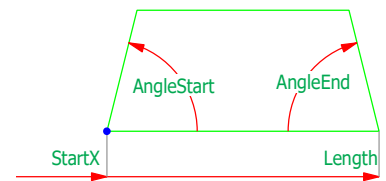
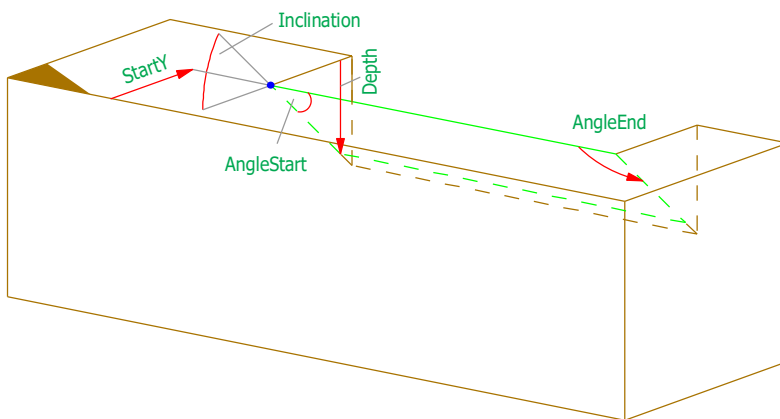

Parameters Longitudinal Cut

Name	Type	Default	Min	Max
StartX	LengthPosType	0.0	-100000.0	100000.0
StartY	WidthType	0.0	0.0	50000.0
Inclination	Inclination2Type	45.0	-90.0	90.0
StartLimited	BooleanType	no	no	yes
EndLimited	BooleanType	no	no	yes
Length	LengthType	0.0	0.0	100000.0
DepthLimited	BooleanType	no	no	yes
Depth	WidthType	0.0	0.0	50000.0
AngleStart	AngleType	90.0	0.1	179.9
AngleEnd	AngleType	90.0	0.1	179.0
ToolPosition	ToolPositionType	left	left/center/right	

StartLimited	EndLimited	
yes	yes	
no	yes	
yes	no	
no	no	

### DoubleCut

Orientation = start

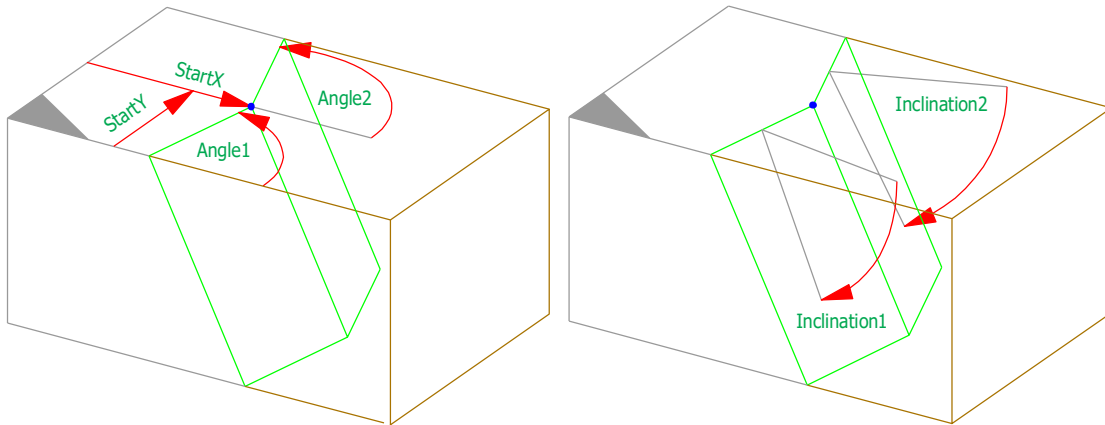

Orientation = end

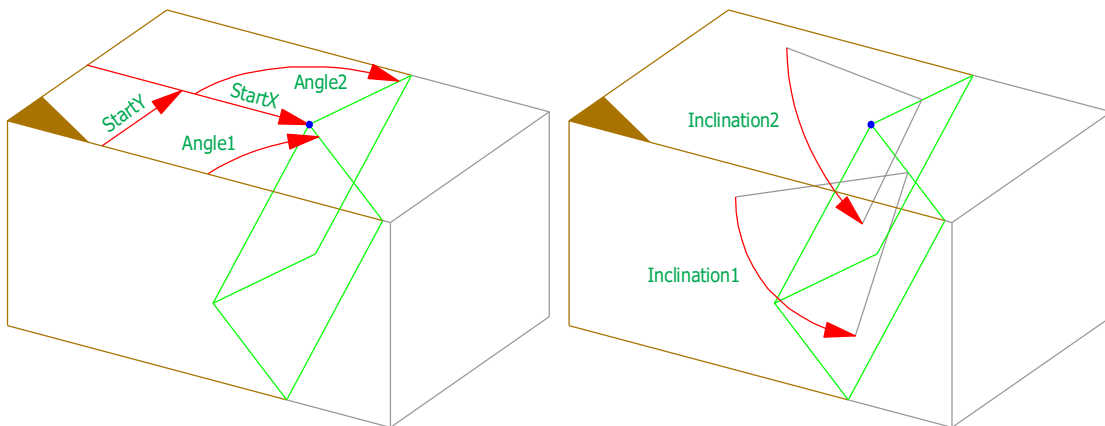

## Parameters Double Cut



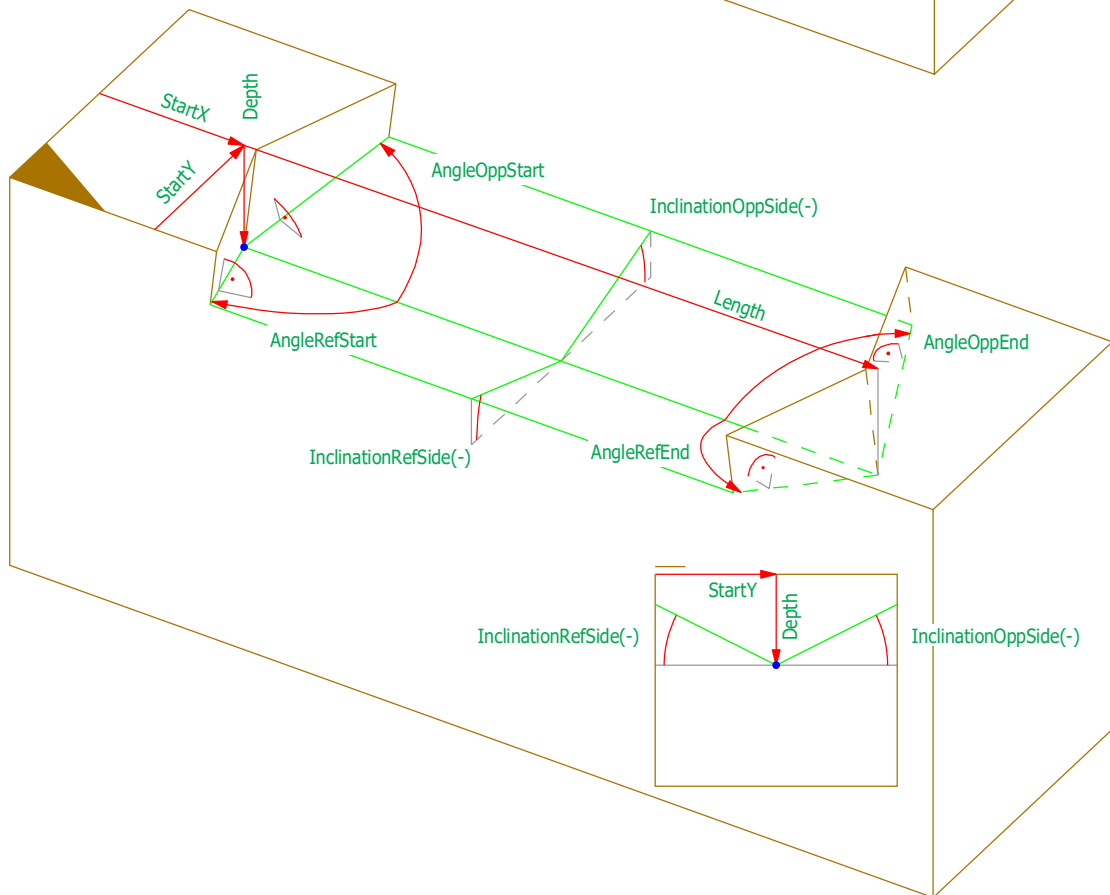
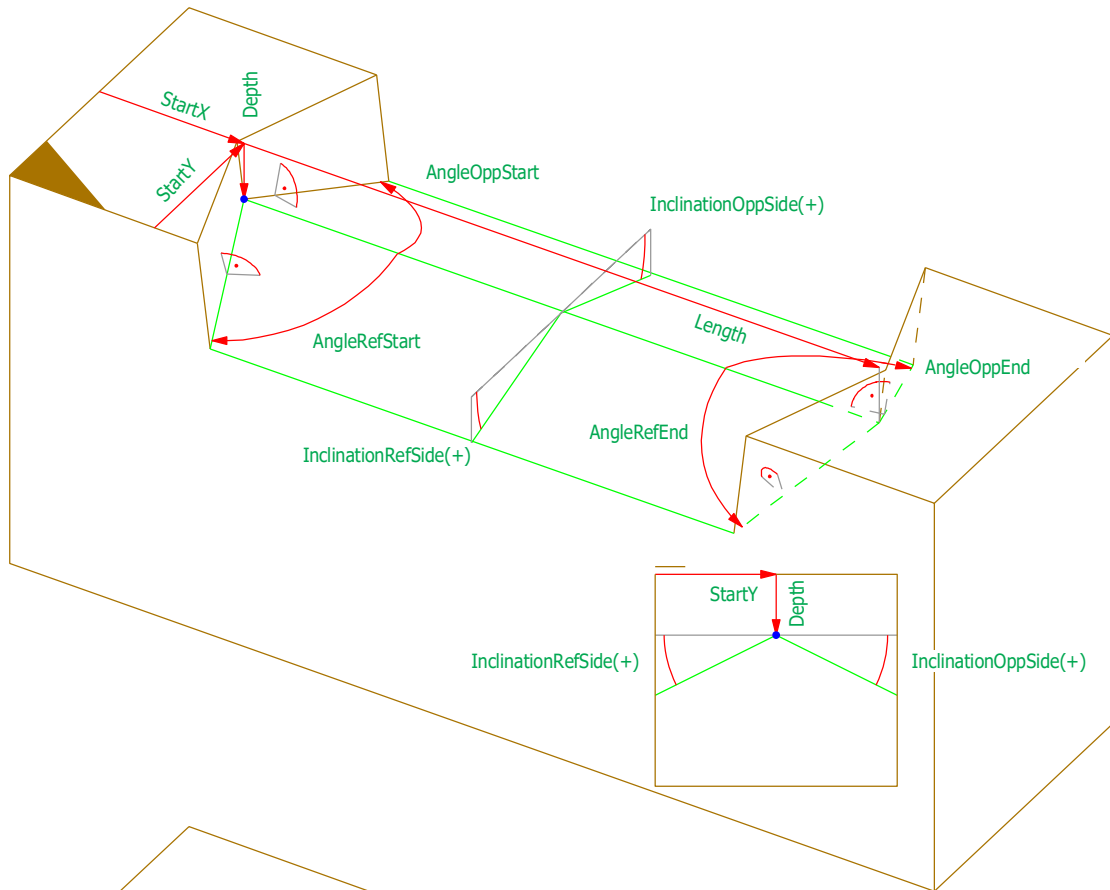

Name	Type	Default	Min	Max
Orientation	OrientationType		start	end
StartX	LengthPosType	0.0	-100000.0	100000.0
StartY	WidthNType	50.0	-50000.0	50000.0
Angle1	AngleType	45.0	0.1	179.9
Inclination1	AngleType	90.0	0.1	179.9
Angle2	AngleType	90.0	0.1	179.9
Inclination2	AngleType	90.0	0.1	179.9

### RidgeValleyCut

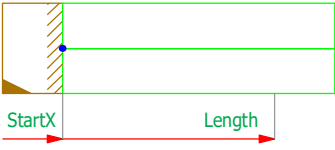

Parameters RidgeValleyCut

Name	Type	Default	Min	Max
StartX	LengthPosType	0.0	-100000.0	100000.0
StartY	WidthType	50.0	0.0	50000.0
StartDepth	WidthNType	0.0	-500000.0	50000.0
InclinationRefSide	InclinationType	45.0	-89.9	89.9
InclinationOppSide	InclinationType	45.0	-89.9	89.9
StartLimited	BooleanType	no	no	yes
EndLimited	BooleanType	no	no	yes
Length	LengthType	0.0	0.0	100000.0
AngleRefStart	AngleType	90.0	0.1	179.9
AngleRefEnd	AngleType	90.0	0.1	179.9
AngleOppStart	AngleType	90.0	0.1	179.9
AngleOppEnd	AngleType	90.0	0.1	179.9

StartLimited	EndLimited	
yes	yes	
no	yes	
yes	no	
no	no	



### SawCut

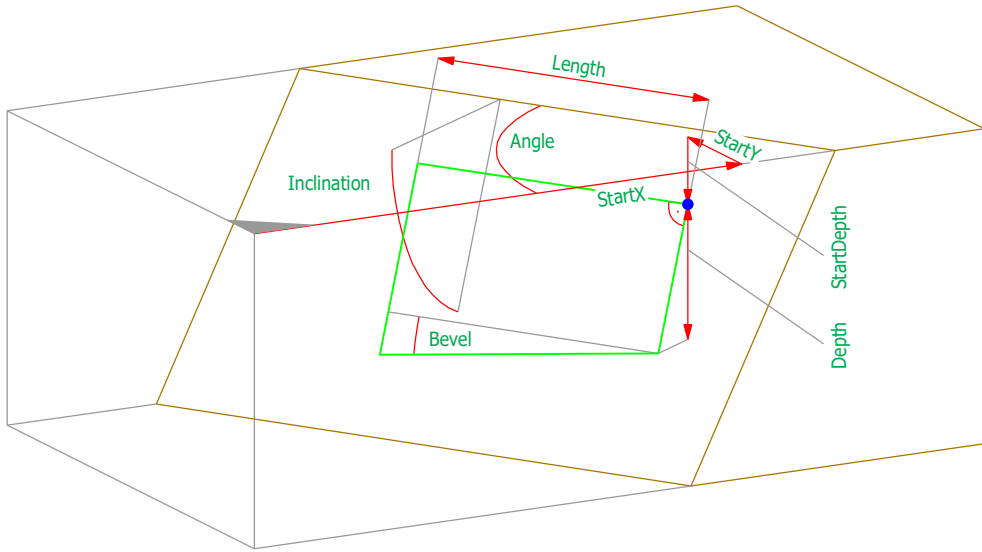

ToolPosition = left

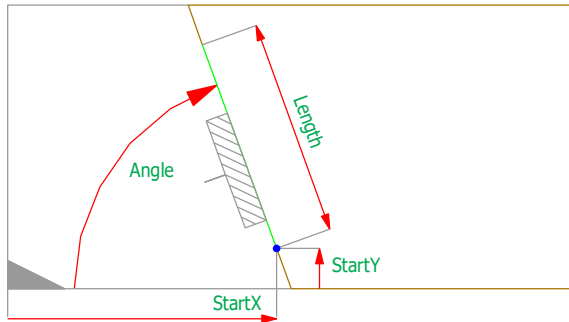

ToolPosition = right

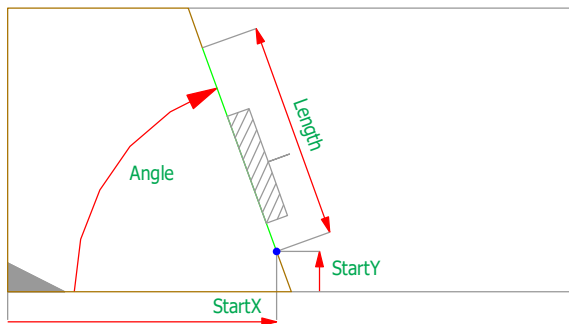

ToolPosition = center

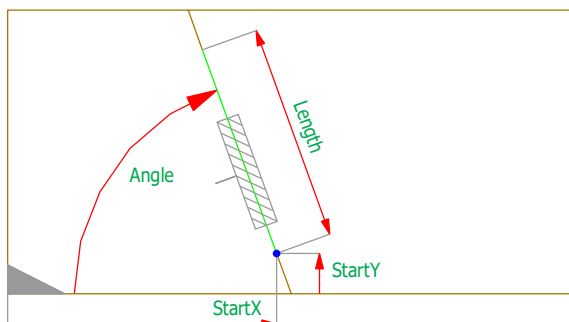

## Parameters SawCut

Name	Type	Default	Min	Max
StartX	LengthPosType	0.0	-100000.0	100000.0
StartY	WidthNType	0.0	-50000.0	50000.0
StartDepth	WidthNType	0.0	-50000.0	50000.0
Angle	Angle2Type	90.0	-180.0	180.0
Inclination	AngleType	90.0	0.1	179.9
Bevel	InclinationType	0.0	-89.9	89.9
Length	LengthType	0.0	0.0	100000.0
Depth	WidthType	50.0	0.0	50000.0
ToolPosition	ToolPositionType	left	left/center/right	

Slot

StartDepth = 0

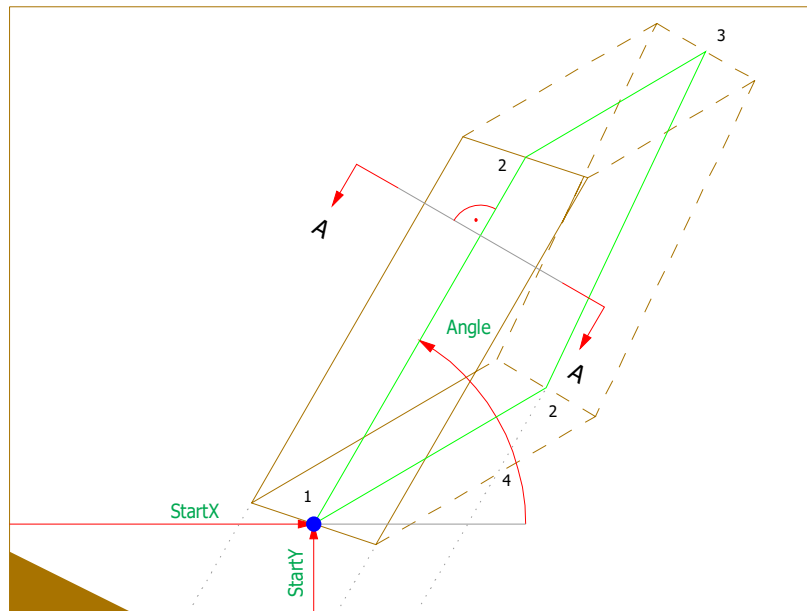
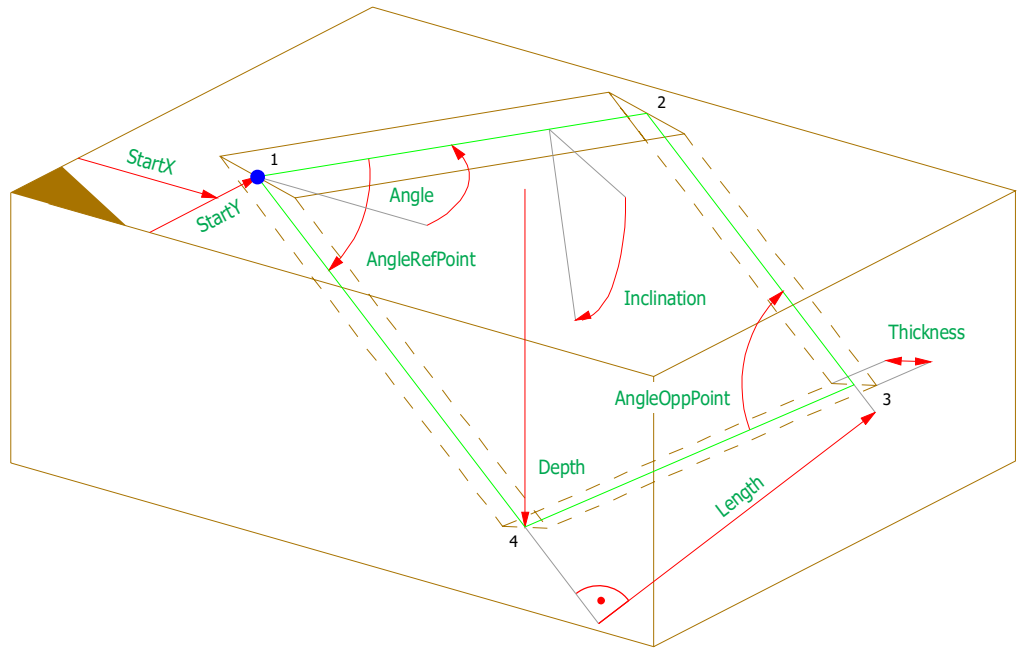

A - A

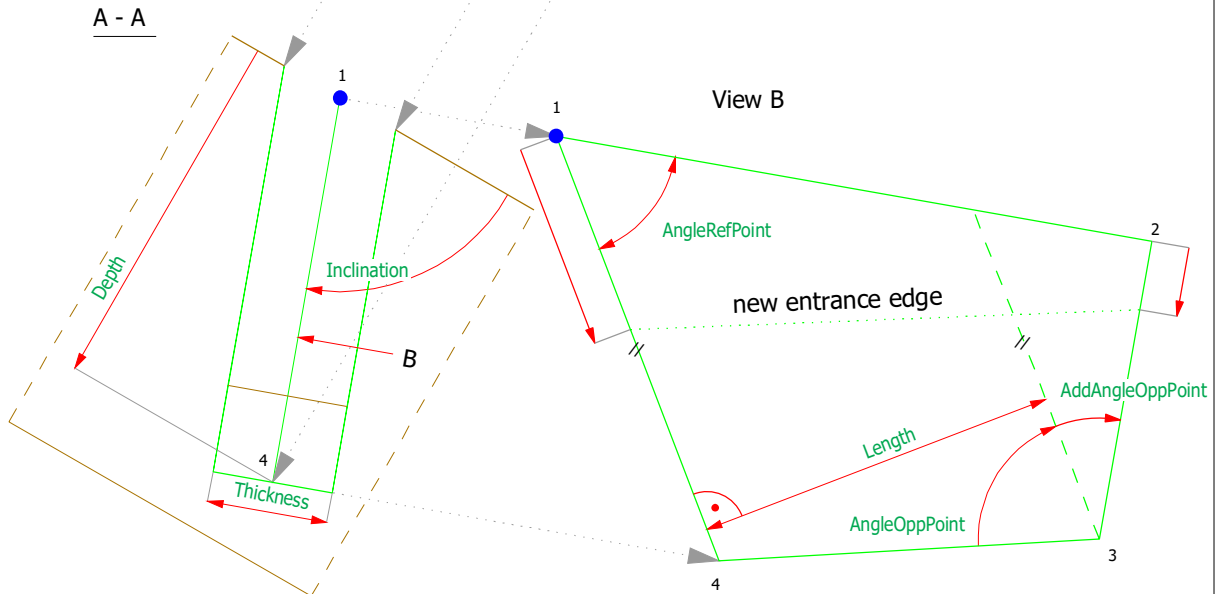

### MachiningLimits

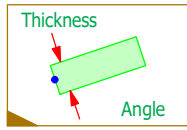

FaceLimitedStart = yes  
 FaceLimitedEnd = yes  
 FaceLimitedFront = yes  
 FaceLimitedBack = yes

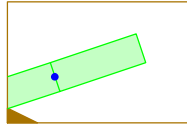

FaceLimitedStart = no

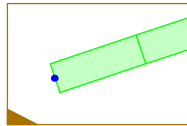

FaceLimitedEnd = no

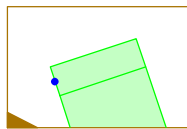

FaceLimitedFront = no

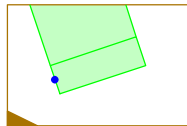

FaceLimitedBack = no

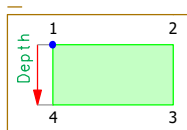

FaceLimitedTop = yes

FaceLimitedBottom = yes

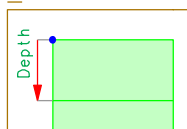

FaceLimitedBottom = no

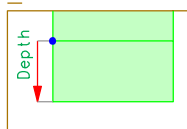

FaceLimitedTop = no

### Other combinations :

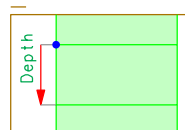
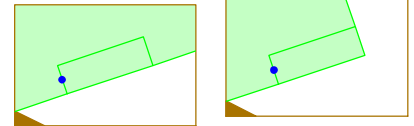
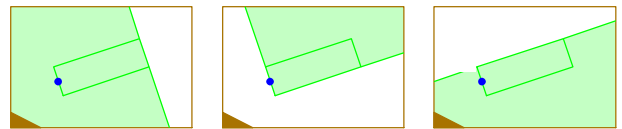
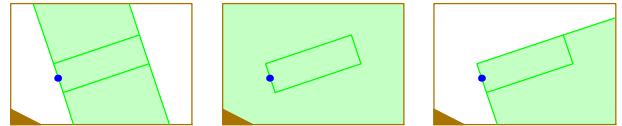
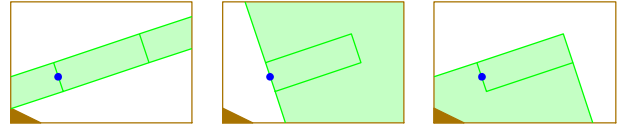

StartDepth <> 0

Orientation = start

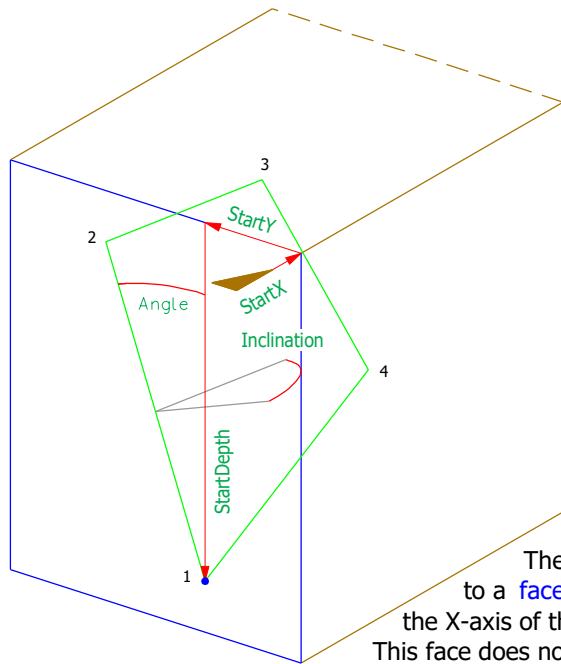

Orientation = end

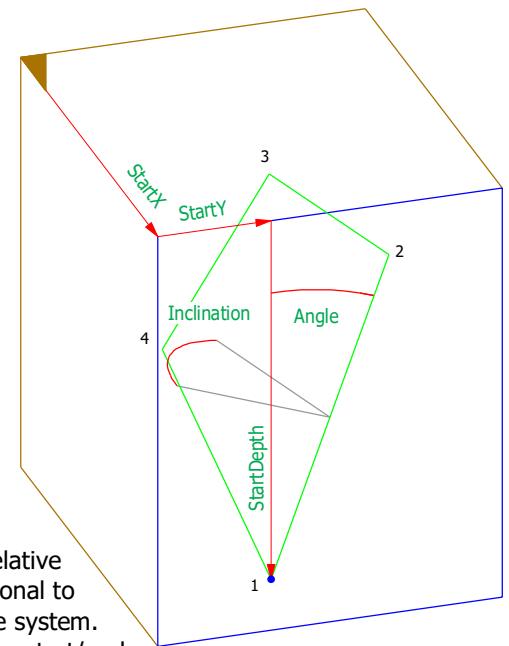

The slot is defined relative to a **face**, which is orthogonal to the X-axis of the part coordinate system. This face does not have to be at the start/end of the beam.

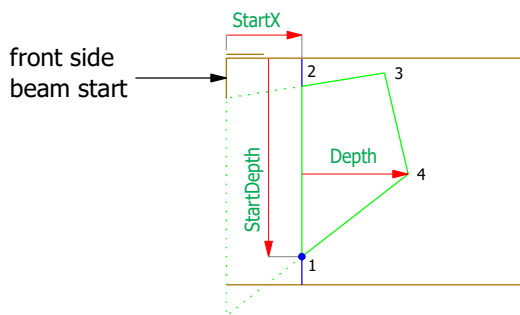

The slot is not limited towards the front sides when StartDepth <> 0.

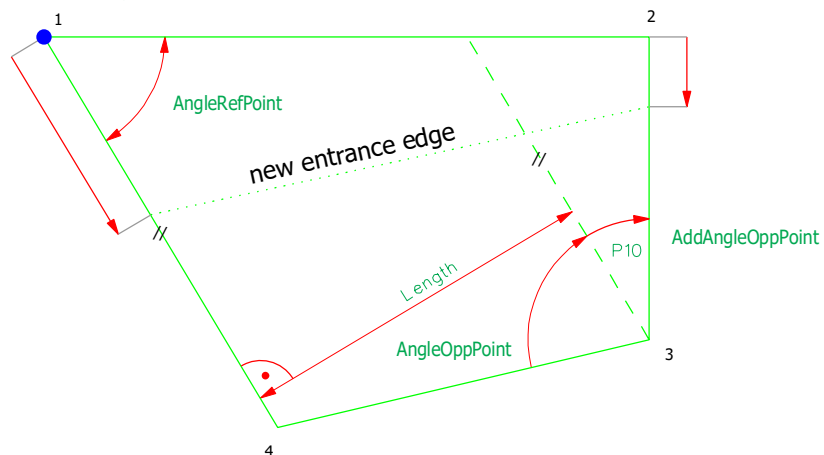
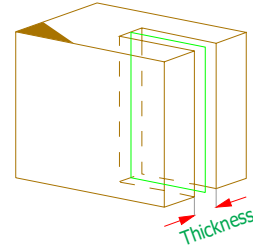
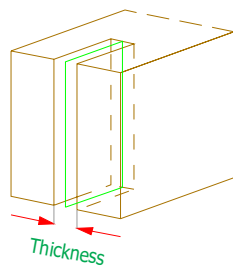
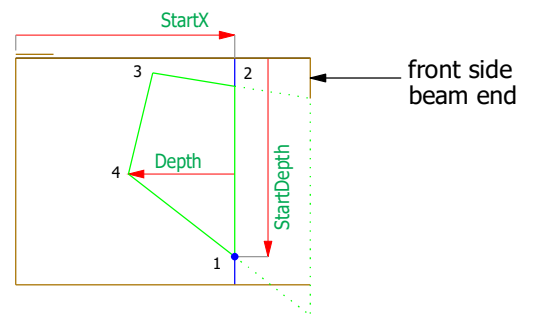

## Parameters Slot

Name	Type	Default	Min	Max
Orientation	OrientationType		start	end
StartX	LengthPosType	0.0	-100000.0	100000.0
StartY	WidthNType	0.0	-50000.0	50000.0
StartDepth	WidthType	0.0	0.0	50000.0
Angle	Inclination2Type	0.0	-90.0	90.0
Inclination	AngleType	90.0	0.1	179.9
Length	LengthType	200.0	0.0	100000.0
Depth	WidthType	10.0	0.0	50000.0
Thickness	WidthType	10.0	0.0	50000.0
AngleRefPoint	AngleType	90.0	0.1	179.9
AngleOppPoint	AngleType	90.0	0.1	179.9
AddAngleOppPoint	AngleNType	0.0	-179.9	179.9
MachiningLimits	MachiningLimitType			

BirdsMouth

Orientation = start

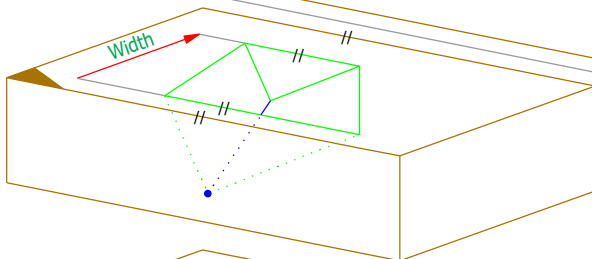
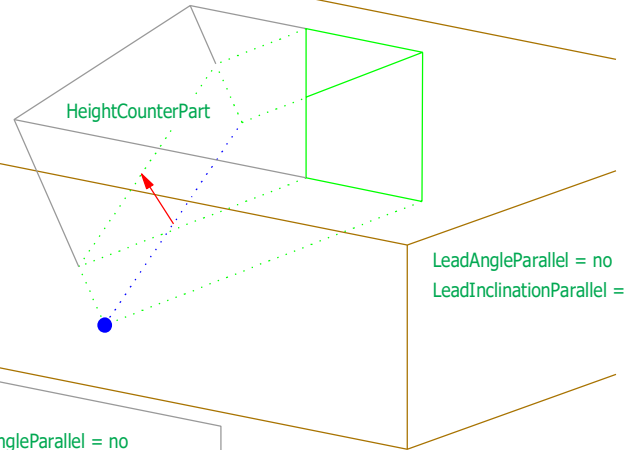
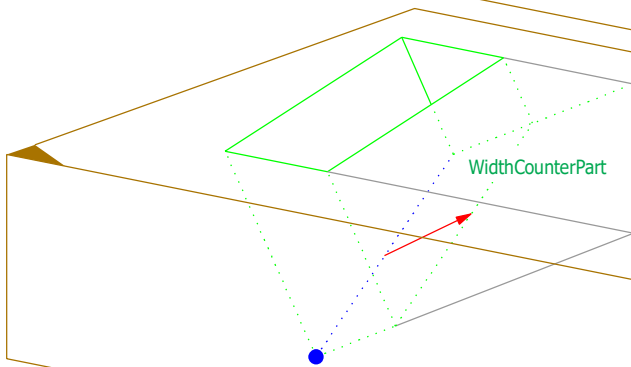
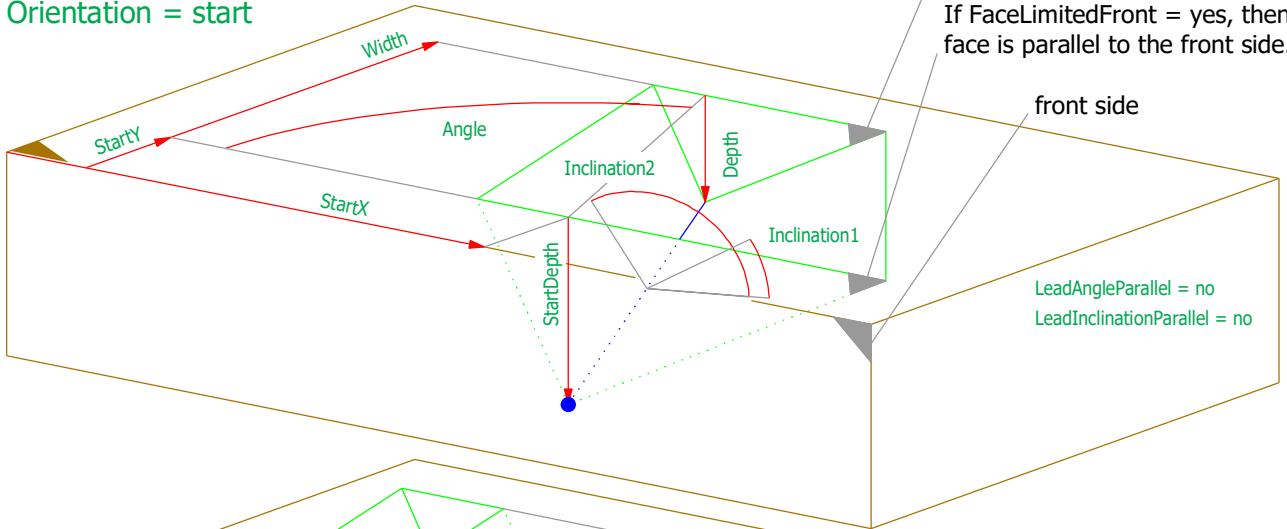

LeadAngleParallel = no  
LeadInclinationParallel = no

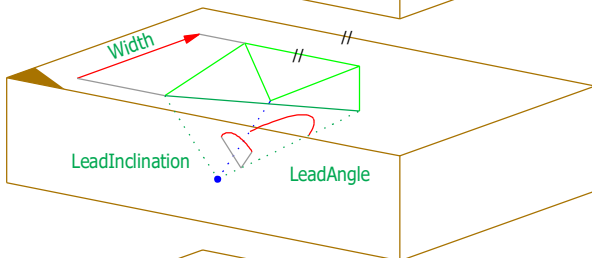

Location of LeadAngle

FaceLimitedFront = yes  
LeadAngleParallel = yes  
LeadInclinationParallel = yes

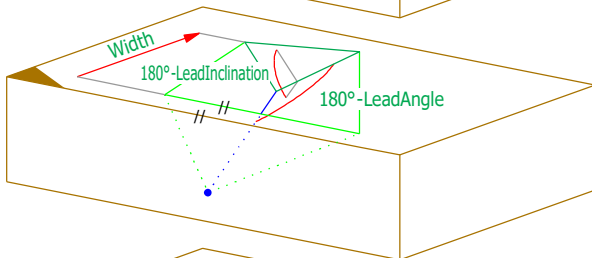

FaceLimitedBack = yes  
LeadAngleParallel = yes  
LeadInclinationParallel = yes

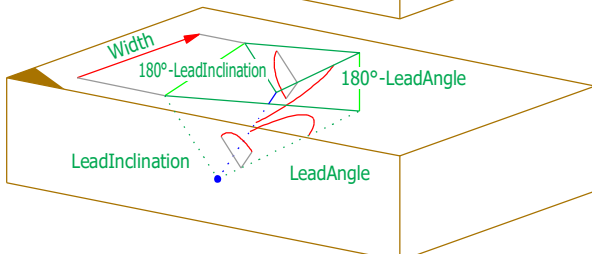

FaceLimitedFront = yes  
FaceLimitedBack = yes  
LeadAngleParallel = yes  
LeadInclinationParallel = yes

Simple example

Angle = 90  
StartDepth = Depth

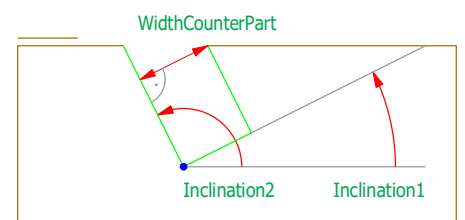
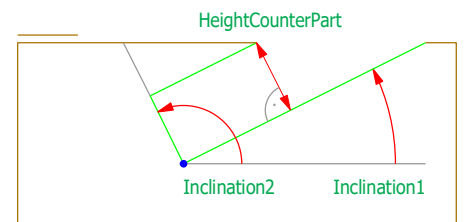
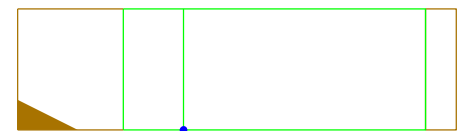

Orientation = end

If FaceLimitedBack = yes, then this face is parallel to the front side.

If FaceLimitedFront = yes, then this face is parallel to the front side.

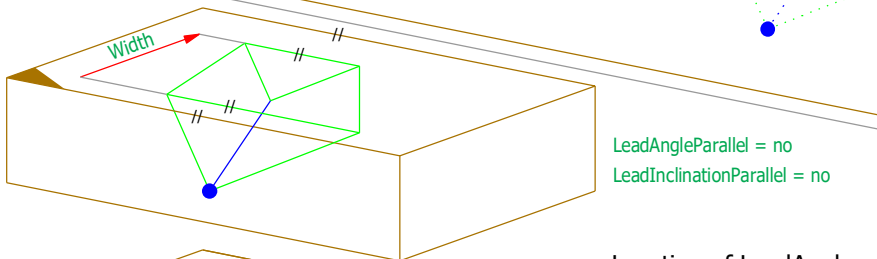
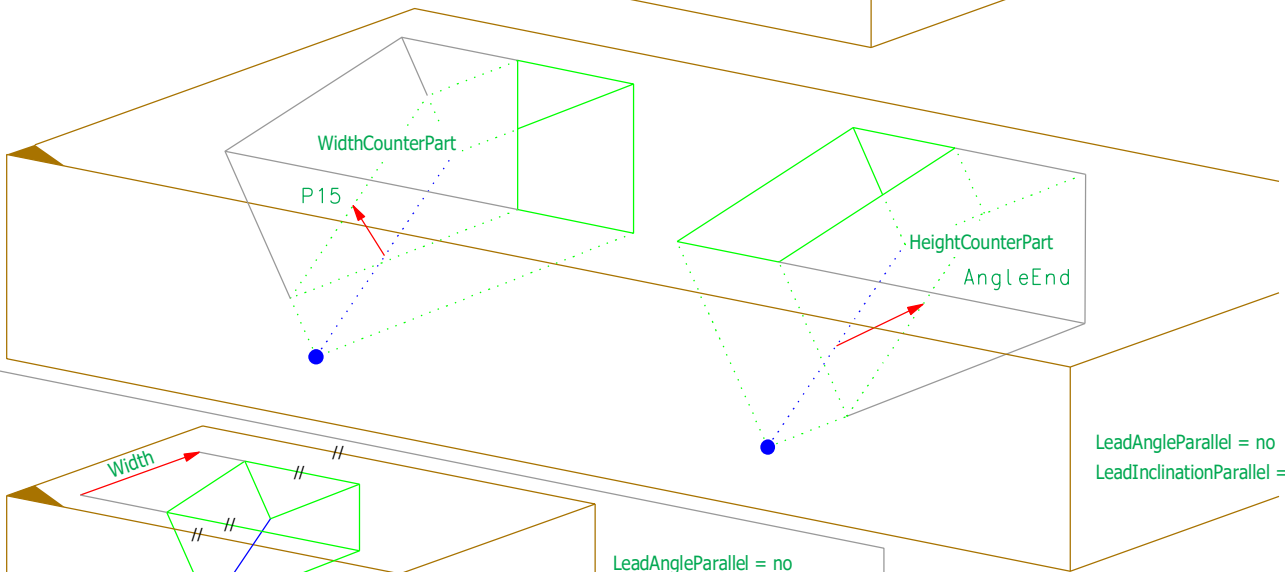
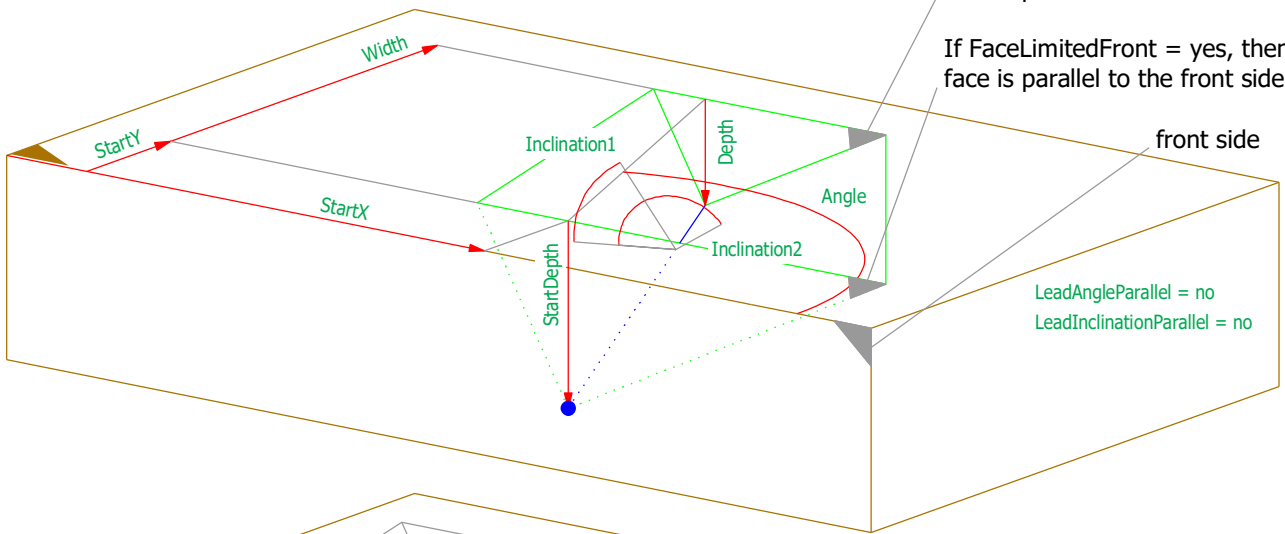

Location of LeadAngle

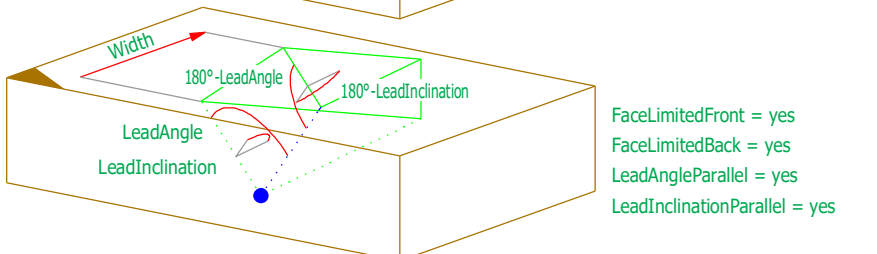
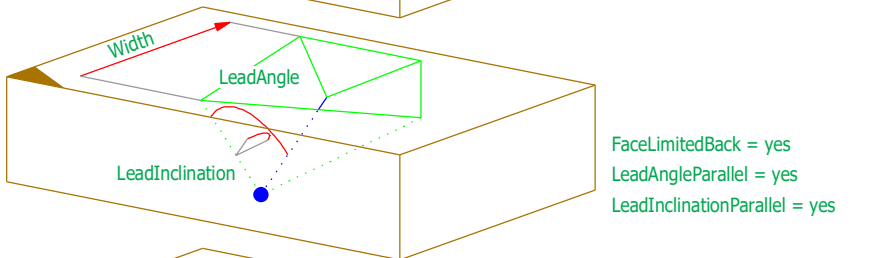
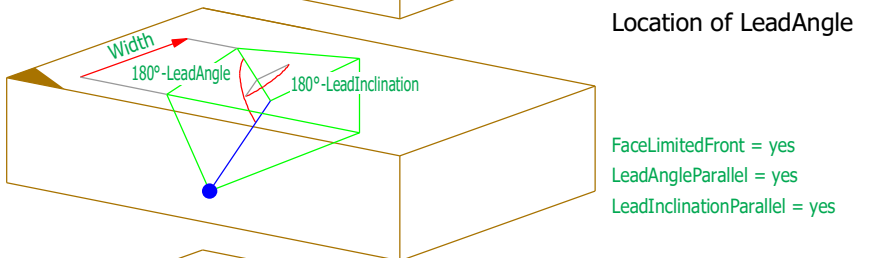

Simple example

Angle = 90  
StartDepth = Depth

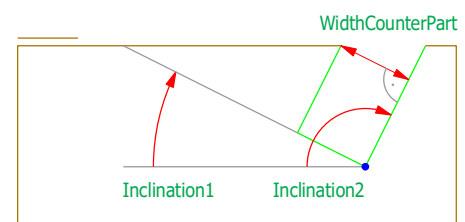
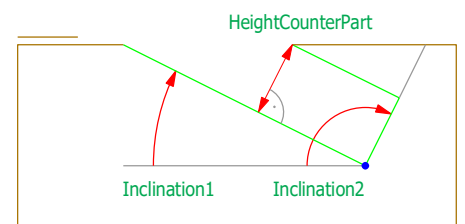
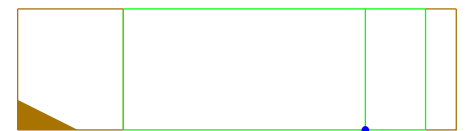



Orientation = start

Another presentation of Inclination1 and Inclination2

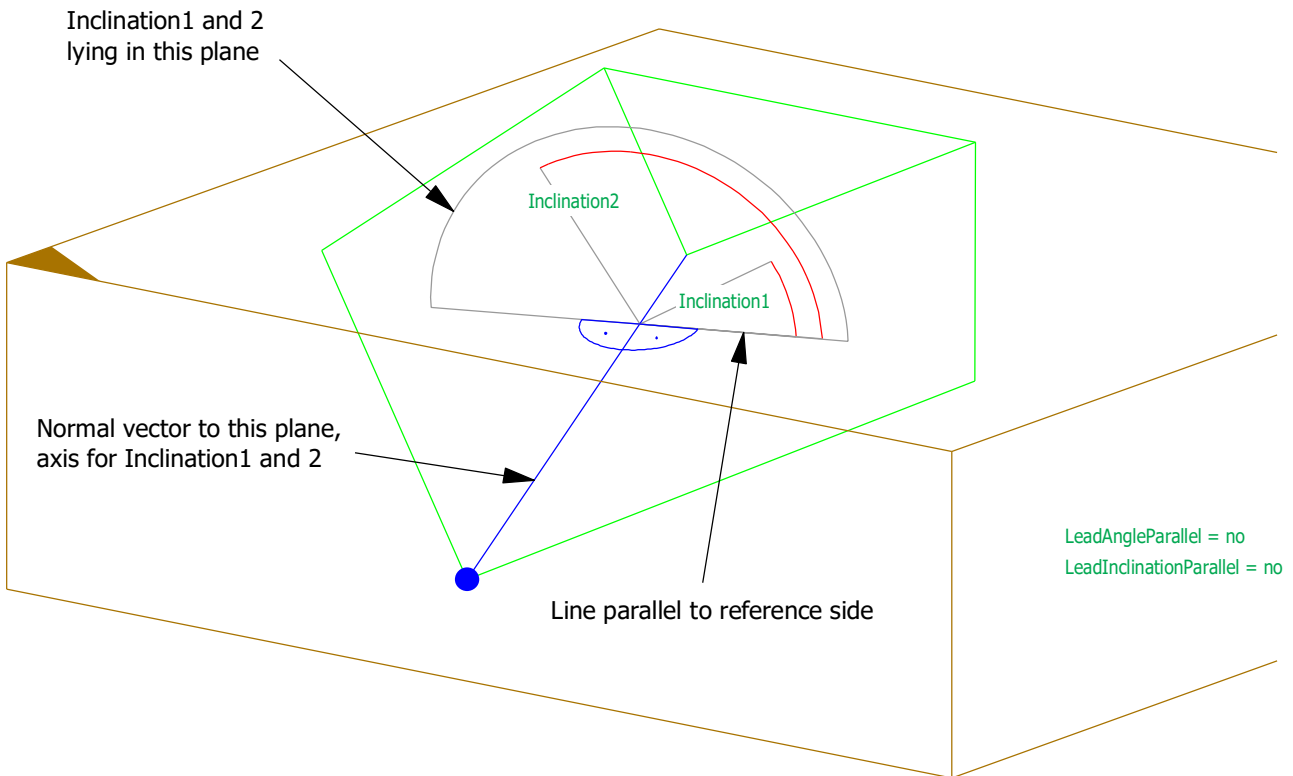

Orientation = end

Another presentation of Inclination1 and Inclination2

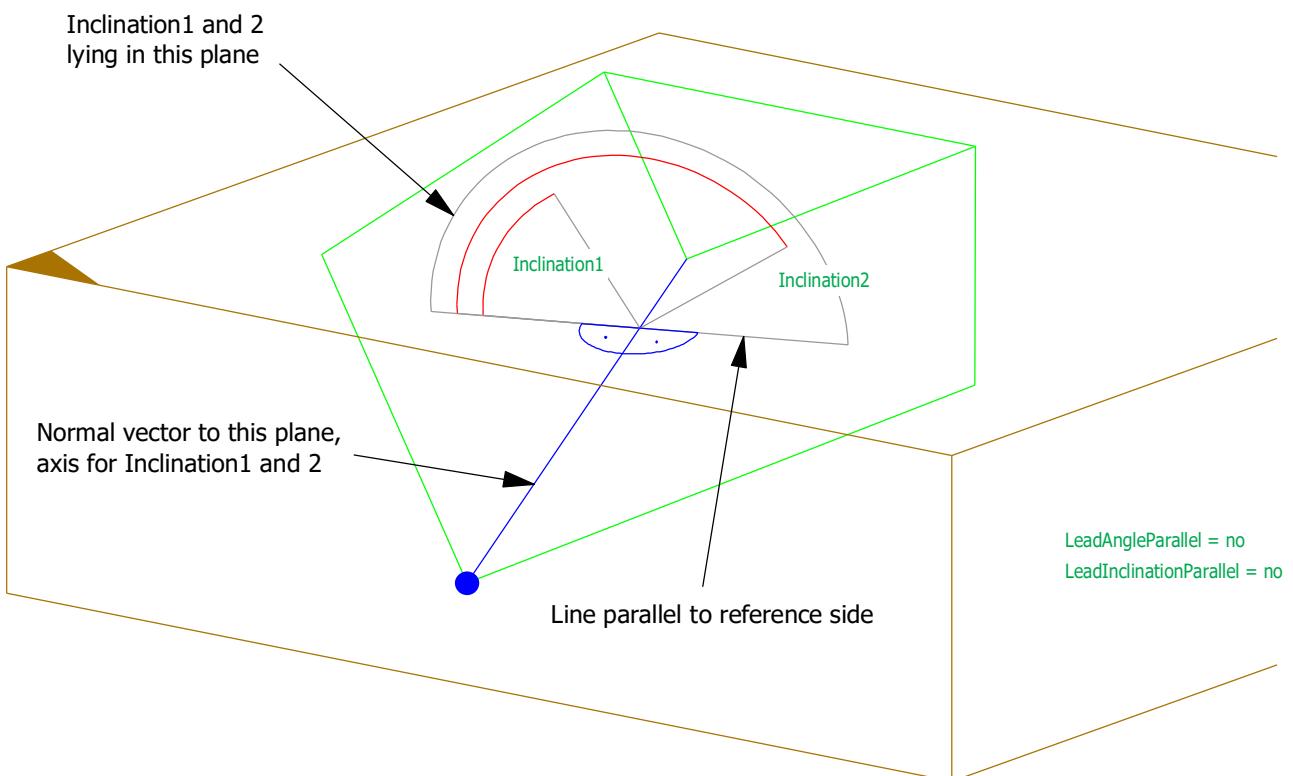

Orientation = start

Another presentation of parameters

View orthogonal to face "Inclination1"

The counterpart enters at the reference edge.

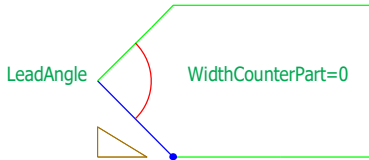

The counterpart enters at opposite of the reference edge.

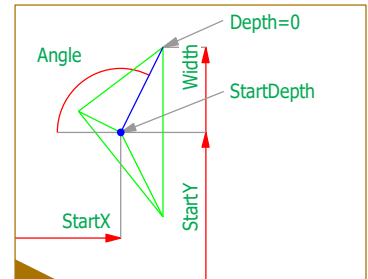
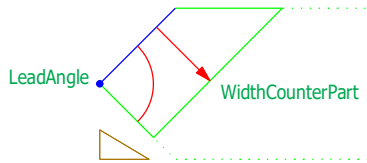
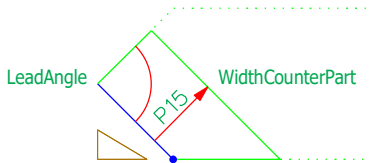
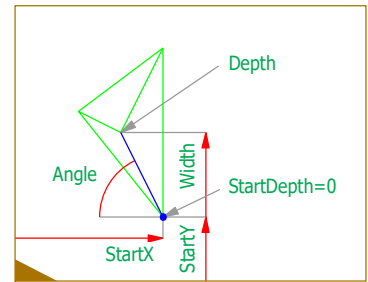
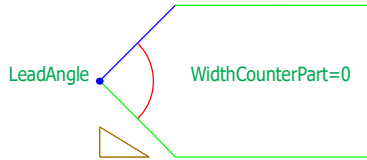

Orientation = end

Another presentation of parameters

View orthogonal to face "Inclination1"

The counterpart enters at the reference edge.

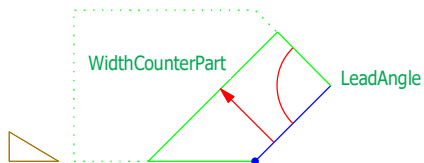

The counterpart enters at opposite of the reference edge.

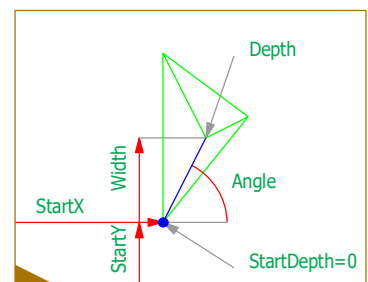
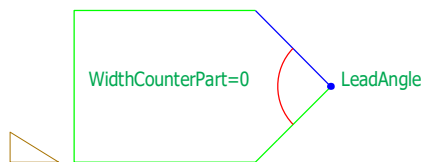
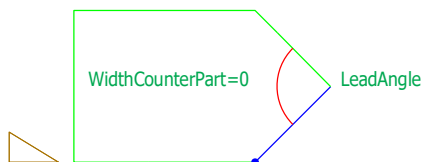
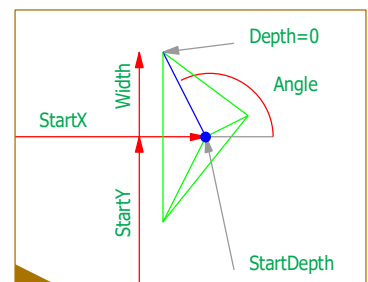
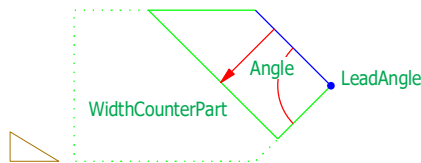

## Parameters BirdsMouth

Name	Type	Default	Min	Max
Orientation	OrientationType		start	end
StartX	LengthPosType	0.0	-100000.0	100000.0
StartY	WidthNType	0.0	-50000.0	50000.0
StartDepth	WidthType	20.0	0.0	50000.0
Angle	AngleType	90.0	0.1	179.9
Inclination1	Angle2Type	45.0	0.0	180.0
Inclination2	Angle2Type	135.0	0.0	180.0
Depth	WidthType	20.0	0.0	50000.0
Width	WidthType	0.0	0.0	50000.0
WidthCounterPartLimited	BooleanType	no	no	yes
WidthCounterPart	WidthType	120.0	0.0	50000.0
HeightCounterPartLimited	BooleanType	no	no	yes
HeightCounterPart	WidthType	120.0	0.0	50000.0
FaceLimitedFront	BooleanType	no	no	yes
FaceLimitedBack	BooleanType	no	no	yes
LeadAngleParallel	BooleanType	yes	no	yes
LeadAngle	AngleType	90.0	0.1	179.9
LeadInclinationParallel	BooleanType	yes	no	yes
LeadInclination	AngleType	90.0	0.1	179.9
RafterNailHole	BooleanType	no	no	yes

### HipValleyRafterNotch

Orientation = start

Orientation = end

hip rafter

hip rafter

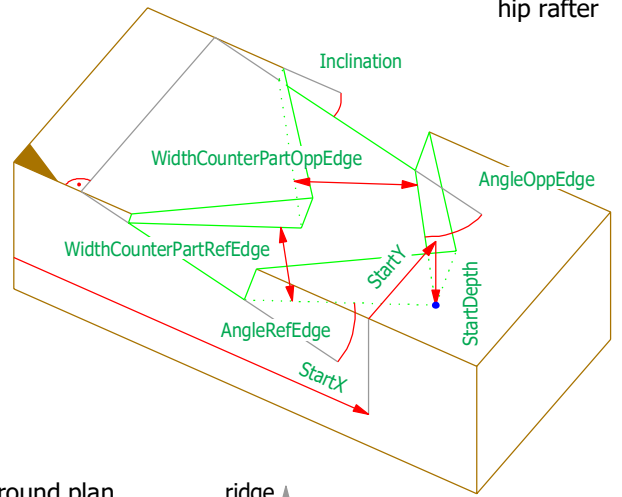
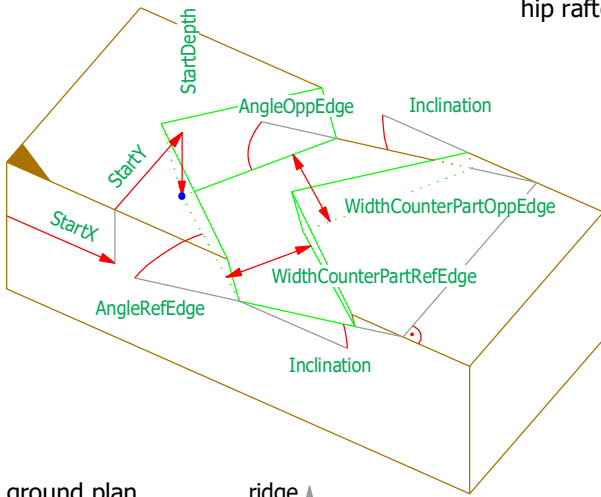

ground plan

ridge ↑

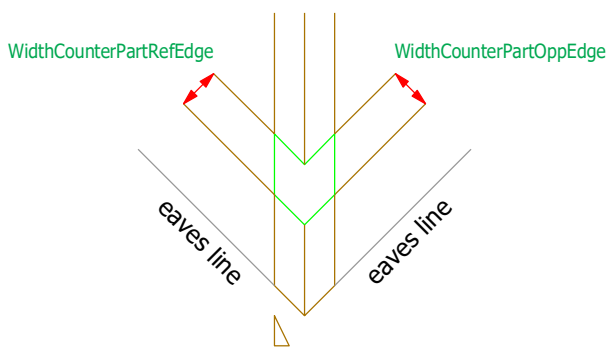

ground plan

ridge ↑

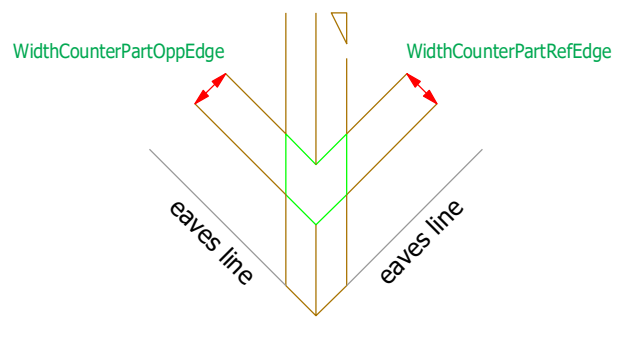

valley rafter

valley rafter

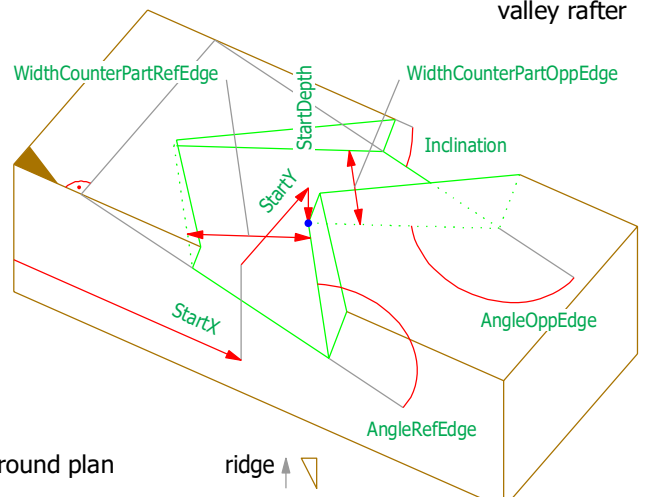
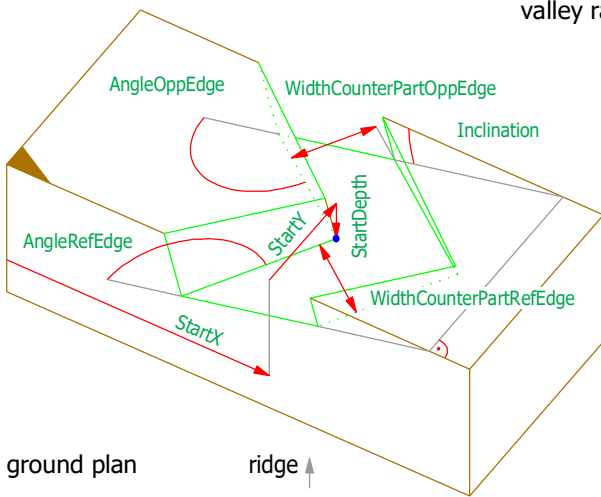

ground plan

ridge ↑

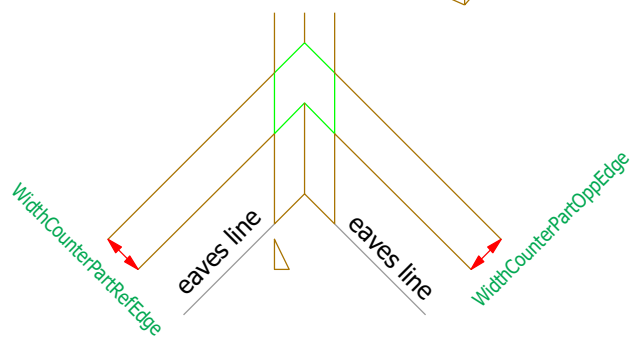

ground plan

ridge ↑

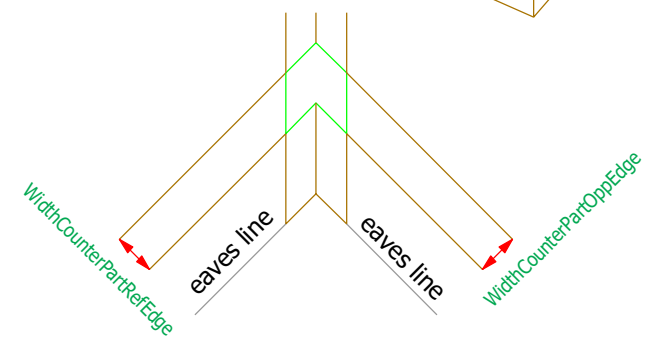

## Parameters HipValleyRafterNotch

Name	Type	Default	Min	Max
Orientation	OrientationType		start	end
StartX	LengthPosType	0.0	-100000	100000
StartY	WidthNType	0.0	-50000	50000
StartDepth	WidthType	20.0	0.0	50000
AngleRefEdge	AngleType	45.0	0.1	179.9
AngleOppEdge	AngleType	45.0	0.1	179.9
Inclination	Angle2Type	30.0	0.0	180.0
WidthCounterPartRefEdgeLimited	BooleanType	no	no	yes
WidthCounterPartRefEdge	WidthType	0.0	0.0	50000
WidthCounterPartOppEdgeLimited	BooleanType	no	no	yes
WidthCounterPartOppEdge	WidthType	0.0	0.0	50000
RafterNailHole	BooleanType	no	no	yes

# Lap

Orientation = start

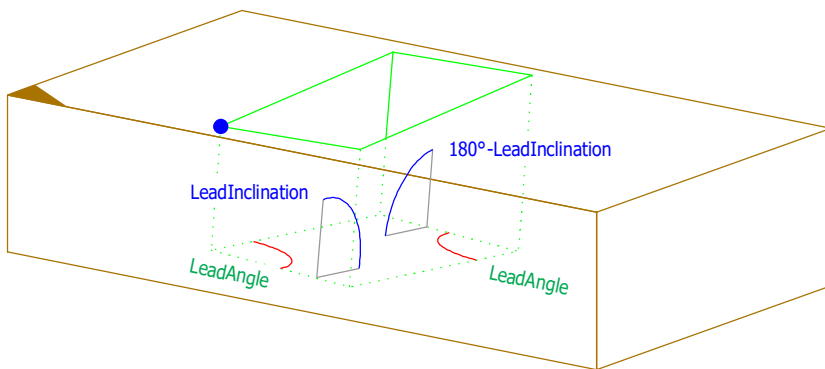
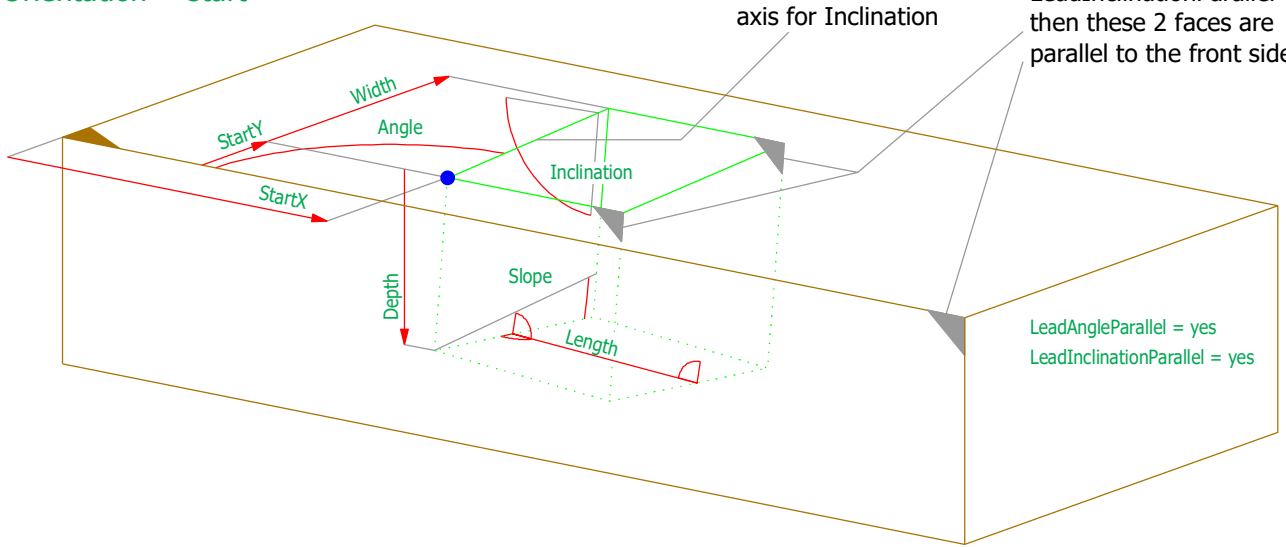

Location of LeadAngle:

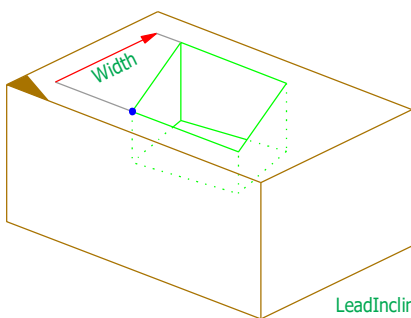

FaceLimitedBack= no

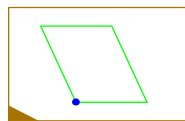

FaceLimitedFront = no

LeadAngleParallel and LeadInclinationParallel are meaningless

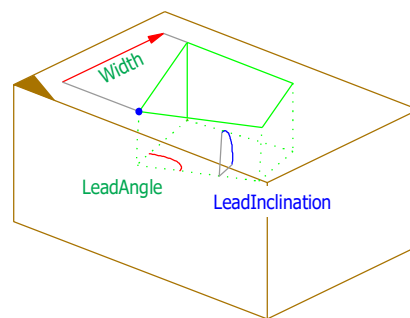

FaceLimitedBack = no

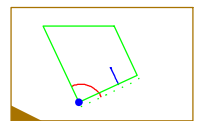

FaceLimitedFront = yes

LeadAngleParallel = no  
LeadInclinationParallel = no

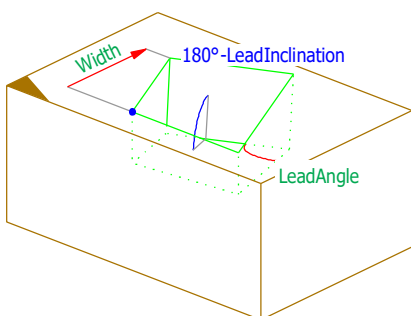

FaceLimitedBack = yes

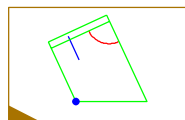

FaceLimitedFront = no

LeadAngleParallel = no  
LeadInclinationParallel = no

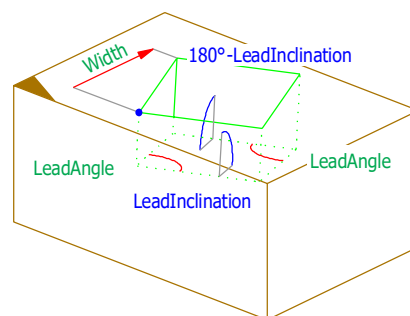

FaceLimitedBack = yes

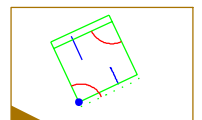

FaceLimitedFront = yes

LeadAngleParallel = no  
LeadInclinationParallel = no

Orientation = end

If LeadAngleParallel = yes and LeadInclinationParallel = yes then these 2 faces are parallel to the front side.

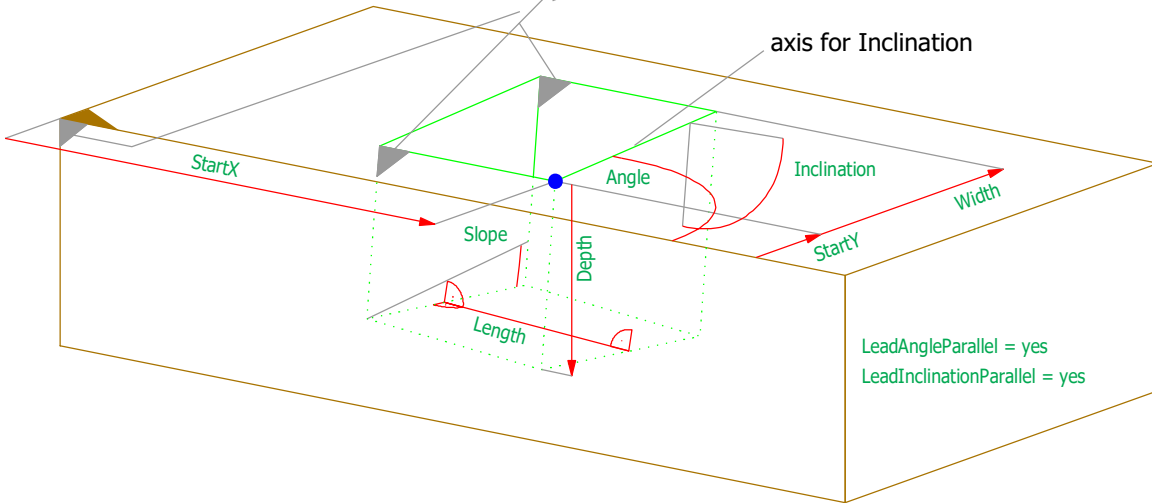

Location of LeadAngle:

LeadAngleParallel = no  
LeadInclinationParallel = no

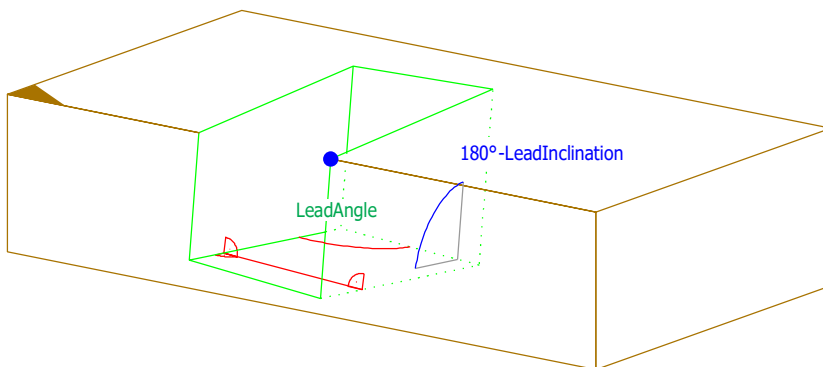

FaceLimitedBack = yes  
FaceLimitedFront = no

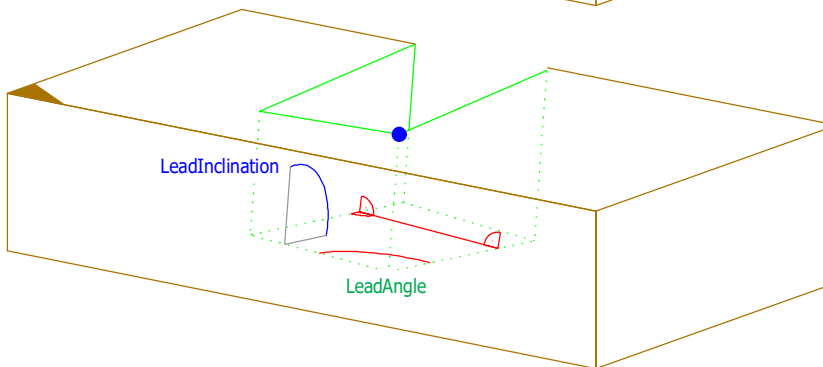

FaceLimitedBack = no  
FaceLimitedFront = yes

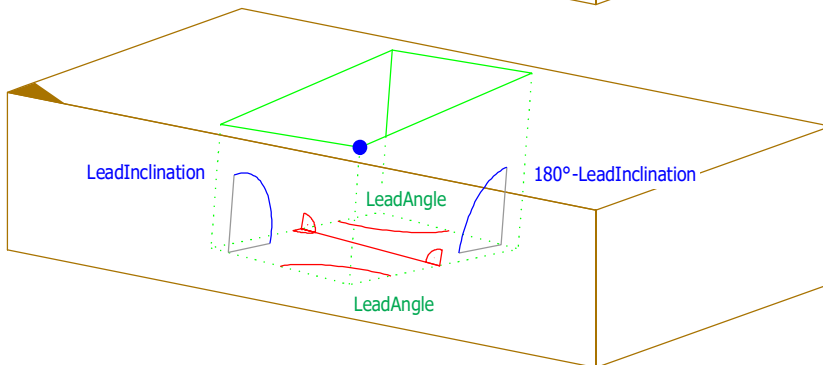

FaceLimitedBack = yes  
FaceLimitedFront = yes

Parameters Lap

Name	Type	Default	Min	Max
Orientation	OrientationType		start	end
StartX	LengthPosType	0.0	-100000	100000
StartY	WidthNTType	0.0	-50000.0	50000
Angle	AngleType	90.0	0.1	179.9
Inclination	AngleType	90.0	0.1	179.9
Slope	InclinationType	0.0	-89.9	89.9
Length	LengthType	200.0	0.0	100000
Width	WidthType	50.0	0.0	50000.0
Depth	WidthNTType	40.0	-50000.0	50000.0
LeadAngleParallel	BooleanType	yes	no	yes
LeadAngle	AngleType	90.0	0.1	179.9
LeadInclinationParallel	BooleanType	yes	no	yes
LeadInclination	AngleType	90.0	0.1	179.9
MachiningLimits	MachiningLimitType			

MachiningLimits

Reference point for Orientation = start

Reference point for Orientation = end

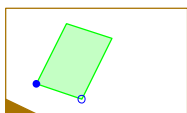
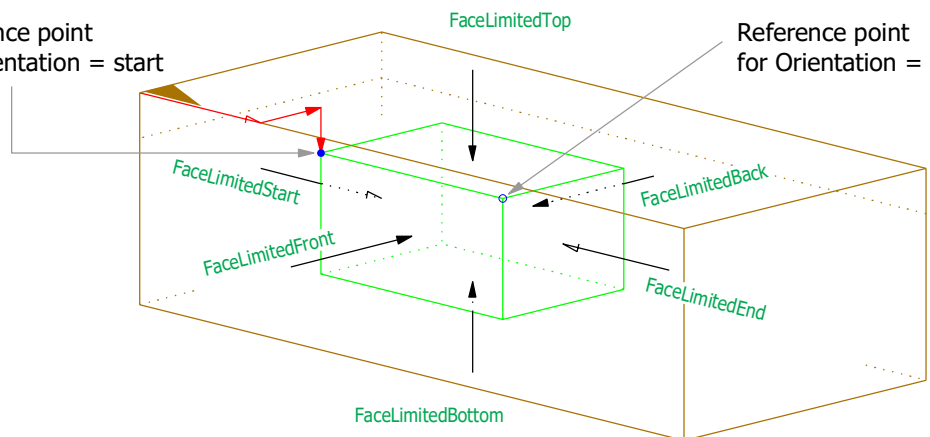

FaceLimitedStart = yes  
FaceLimitedEnd = yes  
FaceLimitedFront = yes  
FaceLimitedBack = yes

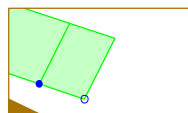

FaceLimitedStart = no  
FaceLimitedEnd = yes  
FaceLimitedFront = yes  
FaceLimitedBack = yes

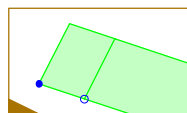

FaceLimitedStart = yes  
FaceLimitedEnd = no  
FaceLimitedFront = yes  
FaceLimitedBack = yes

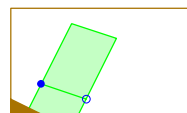

FaceLimitedStart = yes  
FaceLimitedEnd = yes  
FaceLimitedFront = no  
FaceLimitedBack = yes

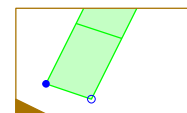

FaceLimitedStart = yes  
FaceLimitedEnd = yes  
FaceLimitedFront = yes  
FaceLimitedBack = no

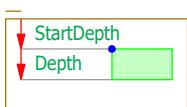

FaceLimitedBottom = yes  
FaceLimitedTop = yes

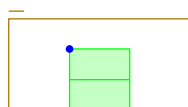

FaceLimitedBottom = no  
FaceLimitedTop = yes

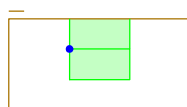

FaceLimitedBottom = yes  
FaceLimitedTop = no

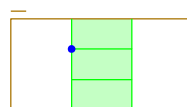

FaceLimitedBottom = no  
FaceLimitedTop = no



Other combinations of MachineLimits

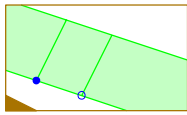

FaceLimitedStart = no  
 FaceLimitedStart = no  
 FaceLimitedFront = no  
 FaceLimitedBack = yes

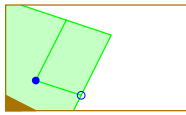

FaceLimitedStart = no  
 FaceLimitedStart = yes  
 FaceLimitedFront = no  
 FaceLimitedBack = yes

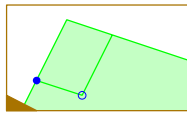

FaceLimitedStart = yes  
 FaceLimitedStart = no  
 FaceLimitedFront = no  
 FaceLimitedBack = yes

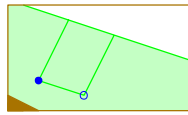

FaceLimitedStart = no  
 FaceLimitedStart = no  
 FaceLimitedFront = no  
 FaceLimitedBack = yes

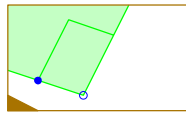

FaceLimitedStart = no  
 FaceLimitedStart = yes  
 FaceLimitedFront = yes  
 FaceLimitedBack = no

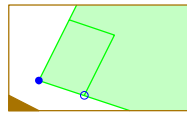

FaceLimitedStart = yes  
 FaceLimitedStart = no  
 FaceLimitedFront = yes  
 FaceLimitedBack = no

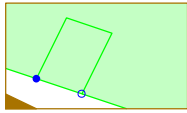

FaceLimitedStart = no  
 FaceLimitedStart = no  
 FaceLimitedFront = yes  
 FaceLimitedBack = no

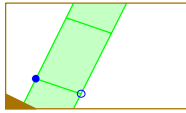

FaceLimitedStart = yes  
 FaceLimitedStart = yes  
 FaceLimitedFront = no  
 FaceLimitedBack = no

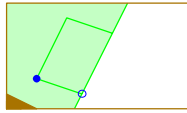

FaceLimitedStart = no  
 FaceLimitedStart = yes  
 FaceLimitedFront = no  
 FaceLimitedBack = no

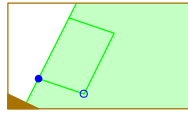

FaceLimitedStart = yes  
 FaceLimitedStart = no  
 FaceLimitedFront = no  
 FaceLimitedBack = no

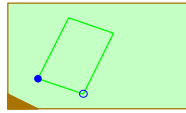

FaceLimitedStart = no  
 FaceLimitedStart = no  
 FaceLimitedFront = no  
 FaceLimitedBack = no

LeadAngle:

LeadAngleParallel = yes  
 LeadInclinationParallel = yes

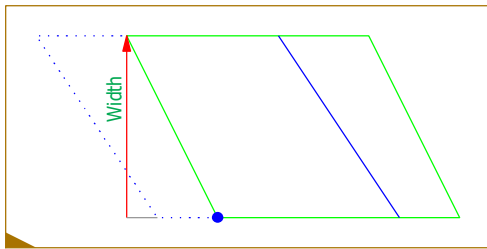

LeadAngleParallel = yes  
 LeadInclinationParallel = no

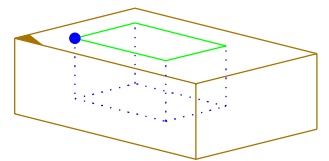
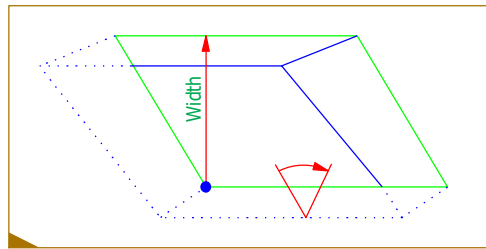

LeadAngleParallel = no  
 LeadInclinationParallel = yes

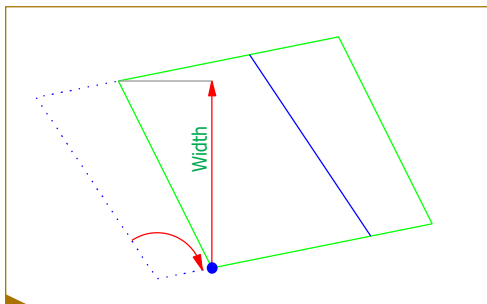

LeadAngleParallel = no  
 LeadInclinationParallel = no

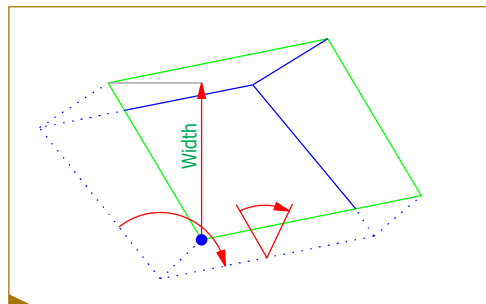

LogHouseHalfLap

Orientation = start

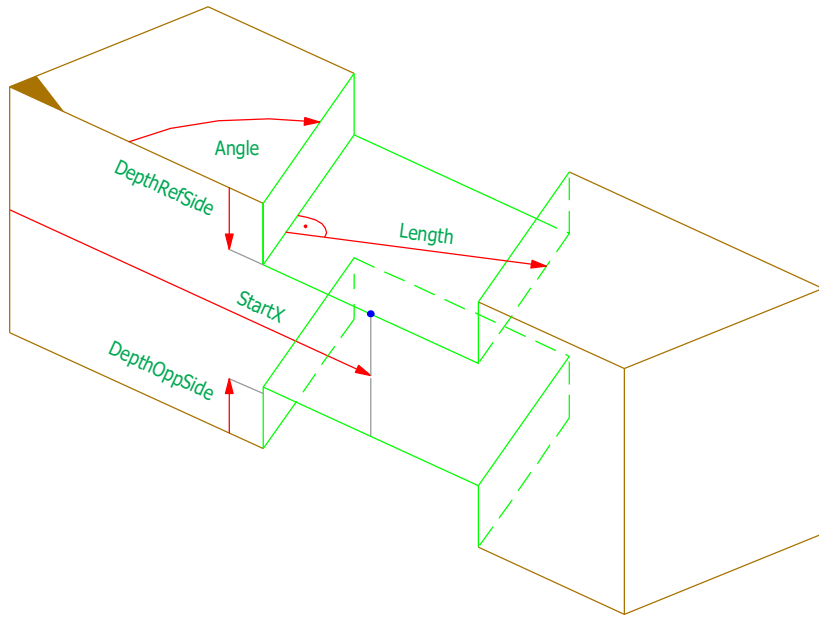

Orientation = end

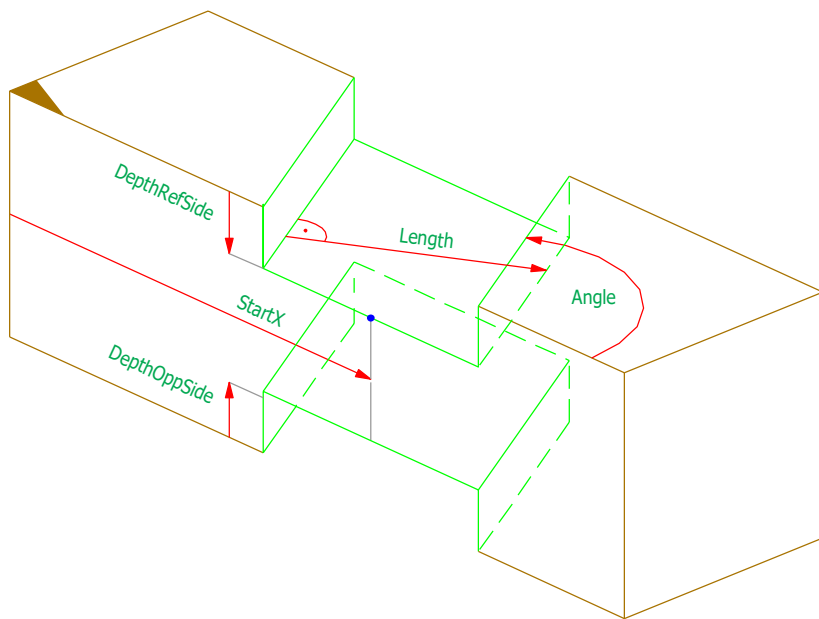

## Parameters LogHouseHalfLap

Name	Type	Default	Min	Max
Orientation	OrientationType		start	end
StartX	LengthPosType	0.0	-100000.0	100000.0
Angle	AngleType	90.0	0.1	179.9
Length	WidthType	120.0	0.0	50000.0
DepthRefSide	WidthType	20.0	0.0	50000.0
DepthOppSide	WidthType	20.0	0.0	50000.0

FrenchRidgeLap

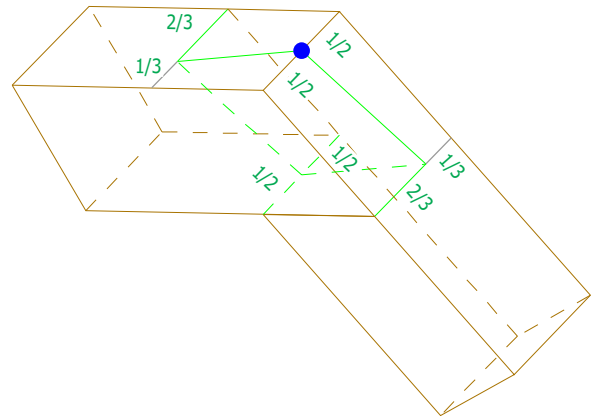
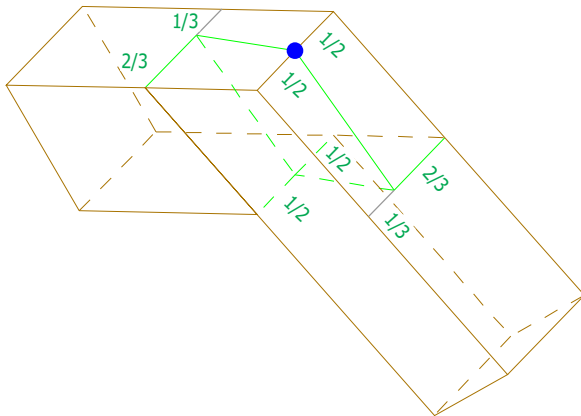

The length of the lap is equal to the width of reference side.

Orientation = start

RefPosition = refedge

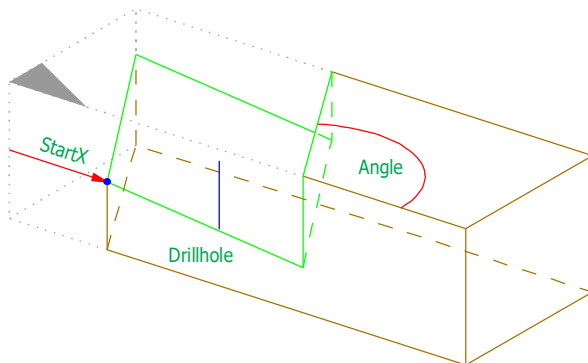

Orientation = start

RefPosition = oppedge

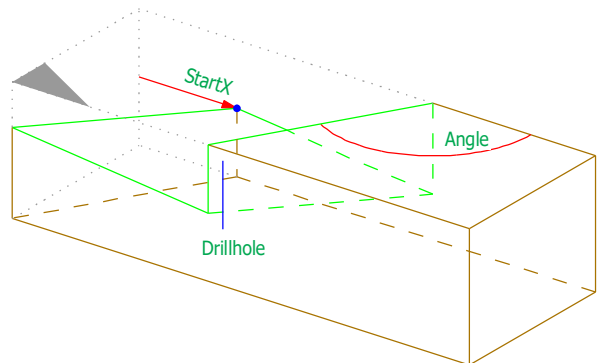

Orientation = end

RefPosition = oppedge

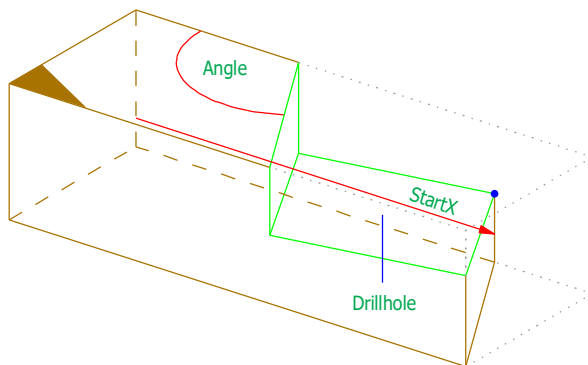

Orientation = end

RefPosition = refedge

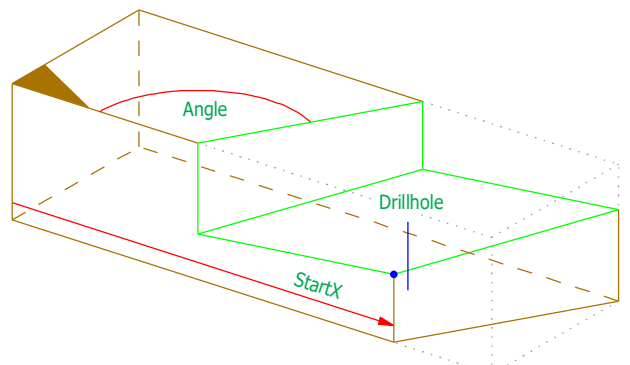

## Parameters FrenchRidgeLap

Name	Type	Default	Min	Max
Orientation	OrientationType		start	end
StartX	LengthPosType	0.0	-100000.0	100000.0
Angle	AngleType	90.0	0.1	179.9
RefPosition	EdgePositionType	refedge	refedge	oppedge
Drillhole	BooleanType	no	no	yes
DrillholeDiam	LengthSType	0.0	0.0	1000.0

### Chamfer

Orientation = start

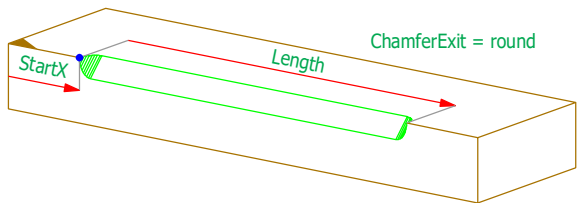
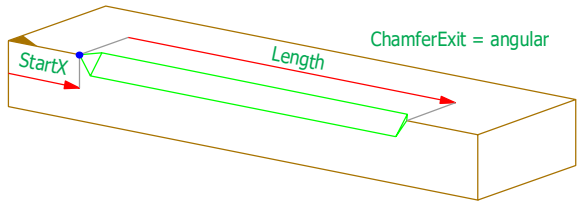
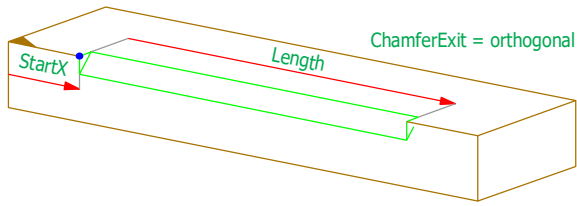

Orientation = end

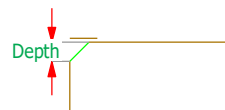
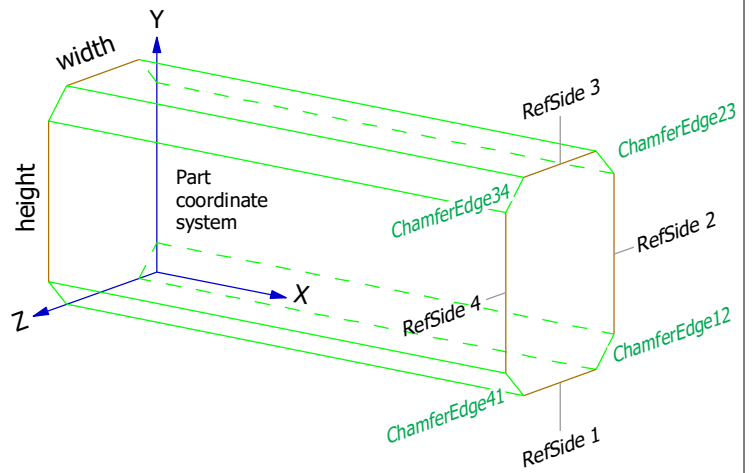
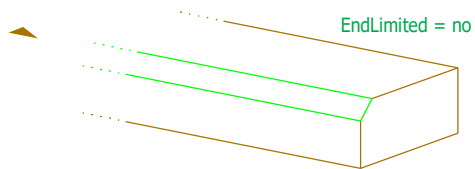
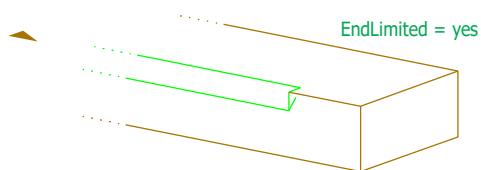
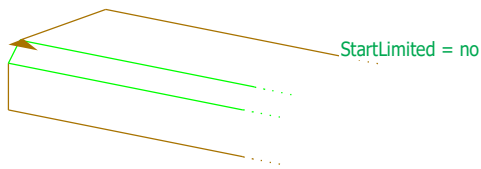
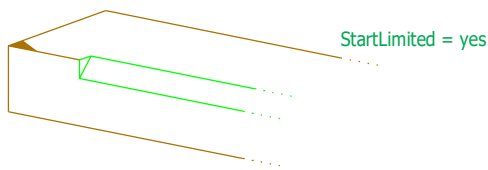
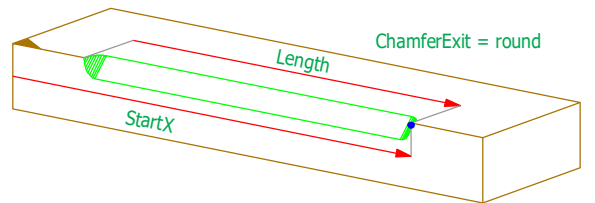
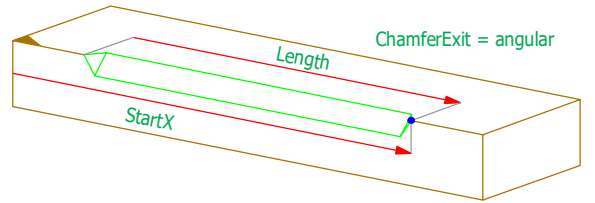
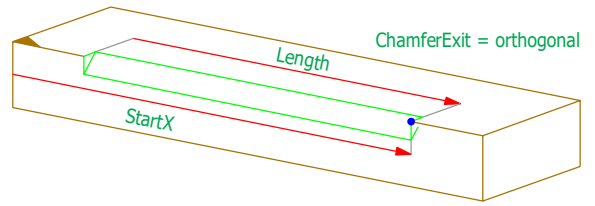

## Parameters Chamfer

Name	Type	Default	Min	Max
StartX	LengthPosType	0.0	-100000.0	100000.0
StartLimited	BooleanType	no	no	yes
EndLimited	BooleanType	no	no	yes
Length	LengthType	0.0	0.0	100000.0
Depth	double	1.0	0.0	100.0
ChamferEdge12	BooleanType	yes	no	yes
ChamferEdge23	BooleanType	yes	no	yes
ChamferEdge34	BooleanType	yes	no	yes
ChamferEdge41	BooleanType	yes	no	yes
ChamferExit	ChamferExitType	orthogonal	orthogonal/angular/round	

### LogHouseJoint

LapPosition = symmetric

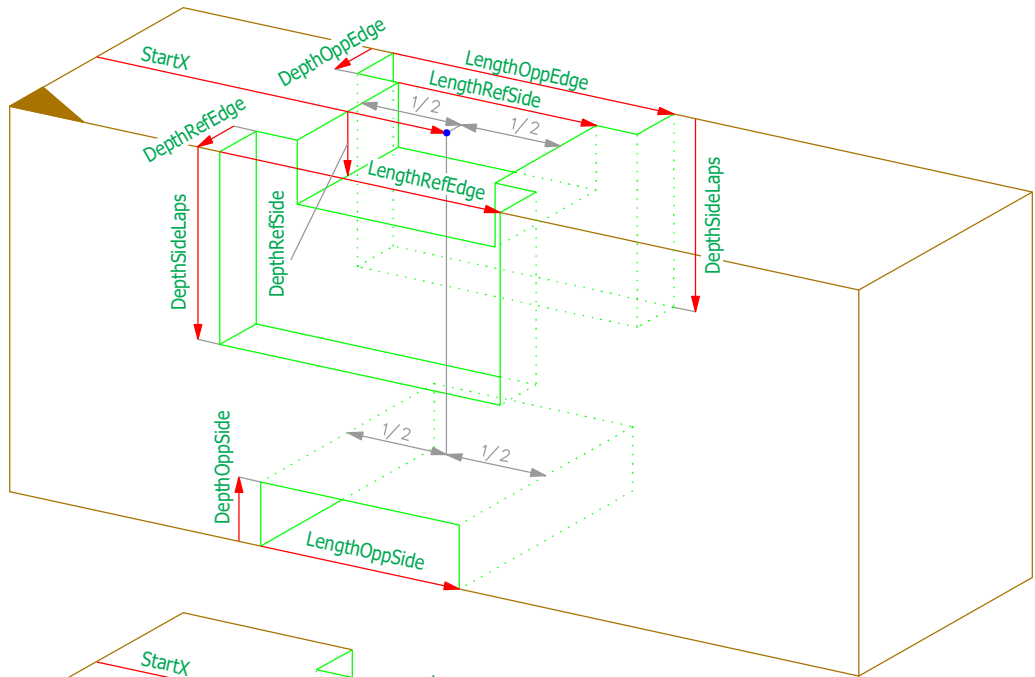

LapPosition = forward

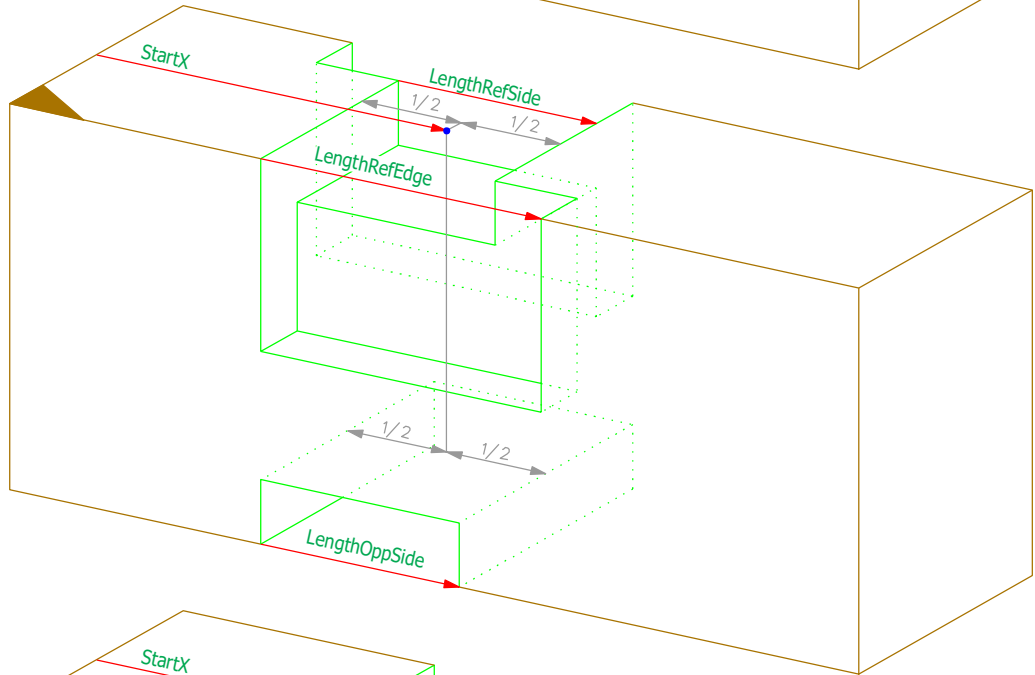

LapPosition = backward

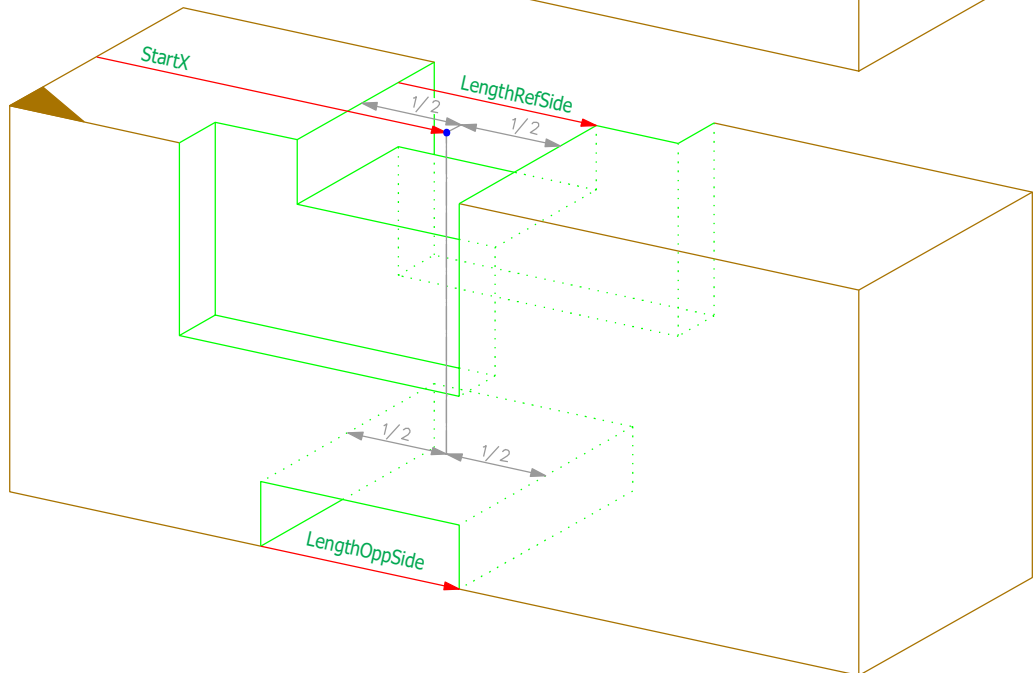



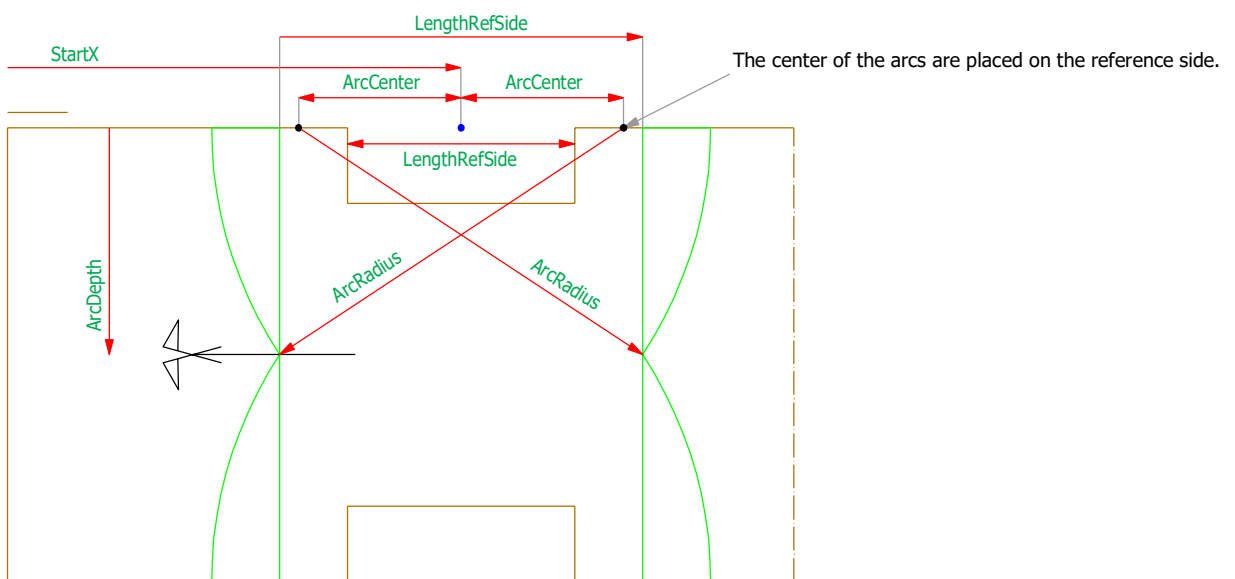
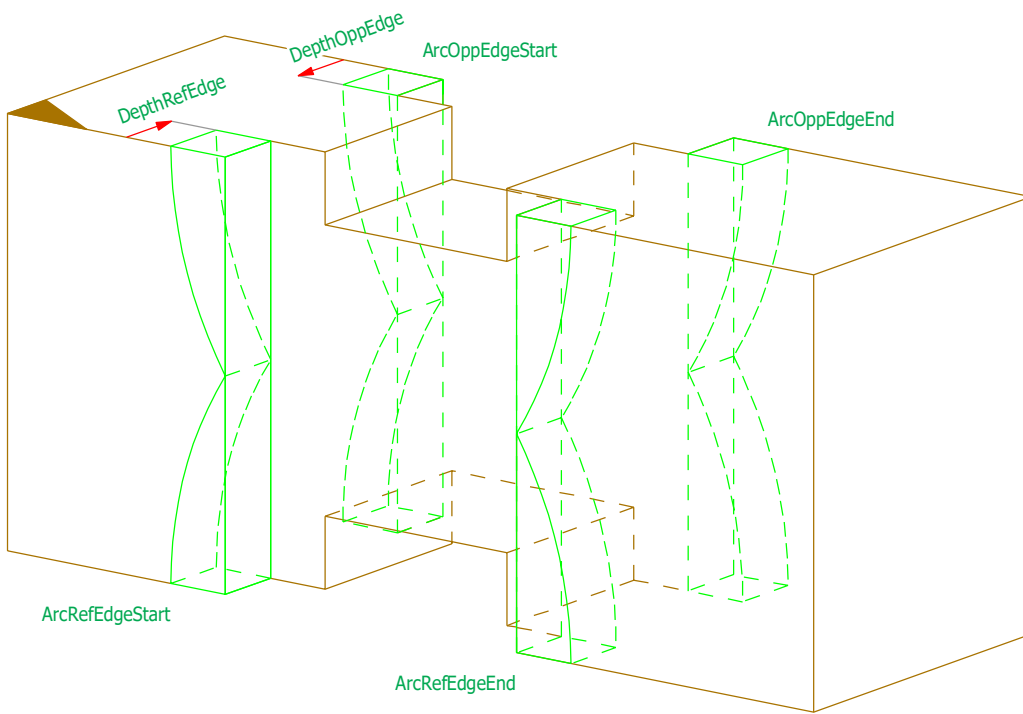
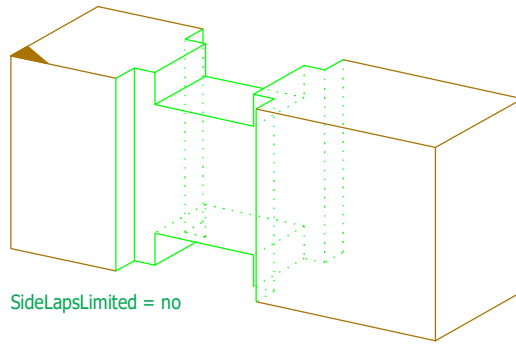
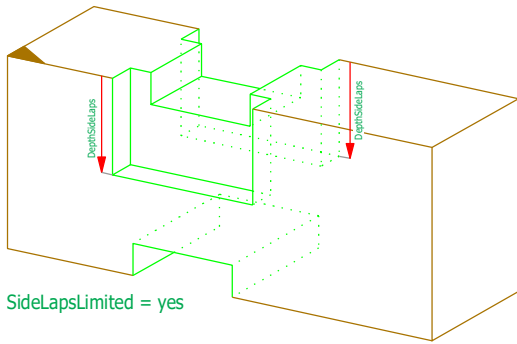

## Parameters LogHouseJoint

Name	Type	Default	Min	Max
StartX	LengthPosType	0.0	-100000.0	100000.0
SideLapsLimited	BooleanType	no	no	yes
DepthSideLaps	WidthType		0.0	50000.0
LapPosition	LogLapPositionType	symmetric	symmetric/forward/backward	
LengthRefSide	WidthType	100.0	0.0	50000.0
DepthRefSide	WidthType	10.0	0.0	50000.0
LengthOppSide	WidthType	100.0	0.0	50000.0
DepthOppSide	WidthType	10.0	0.0	50000.0
LengthRefEdge	WidthType	100.0	0.0	50000.0
DepthRefEdge	WidthType	10.0	0.0	50000.0
LengthOppEdge	WidthType	100.0	0.0	50000.0
DepthOppEdge	WidthType	10.0	0.0	50000.0
Drillhole	BooleanType	no	no	yes
ArcRefEdgeStart	BooleanType	no	no	yes
ArcRefEdgeEnd	BooleanType	no	no	yes
ArcOppEdgeStart	BooleanType	no	no	yes
ArcOppEdgeEnd	BooleanType	no	no	yes
ArcRadius	WidthType	120.0	0.0	50000.0
ArcDepth	WidthNType	60.0	-50000.0	50000.0
ArcCenter	WidthType	120.0	0.0	50000.0

### LogHouseFront

Orientation = start

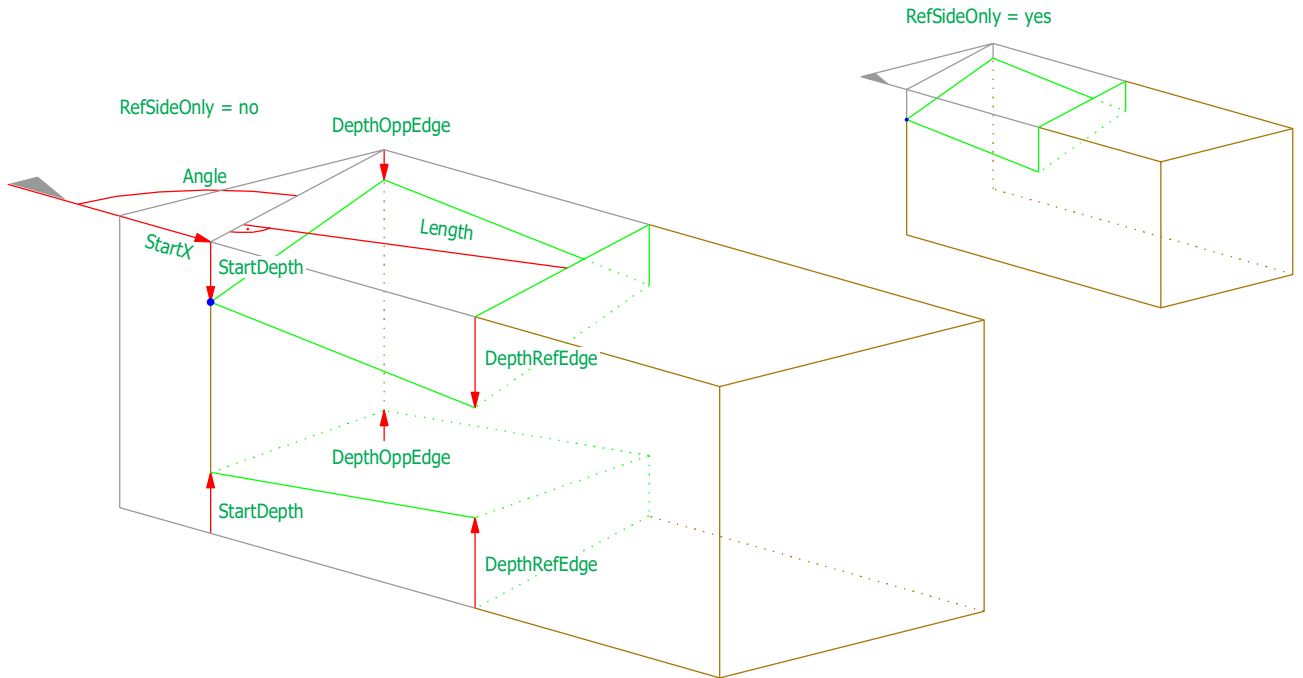

Orientation = end

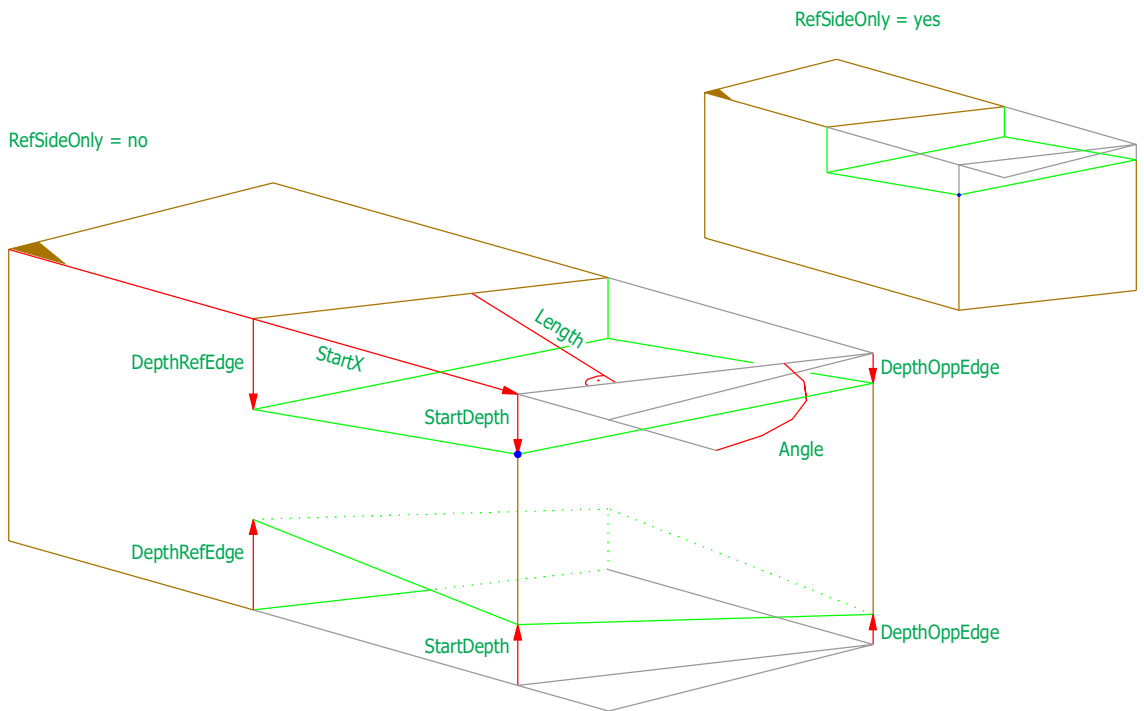

## Parameters LogHouseFront

Name	Type	Default	Min	Max
Orientation	OrientationType		start	end
StartX	LengthPosType	0.0	-100000.0	100000.0
StartDepth	WidthType	20.0	0.0	50000.0
Angle	AngleType	90.0	0.1	179.9
Length	WidthType	120.0	0.0	50000.0
DepthRefEdge	WidthType	20.0	0.0	50000.0
DepthOppEdge	WidthType	20.0	0.0	50000.0
RefSideOnly	BooleanType	no	no	yes

Pocket

here: TiltStartSide = 90  
 TiltEndSide = 90  
 TiltRefSide = 90  
 TiltOppSide = 90

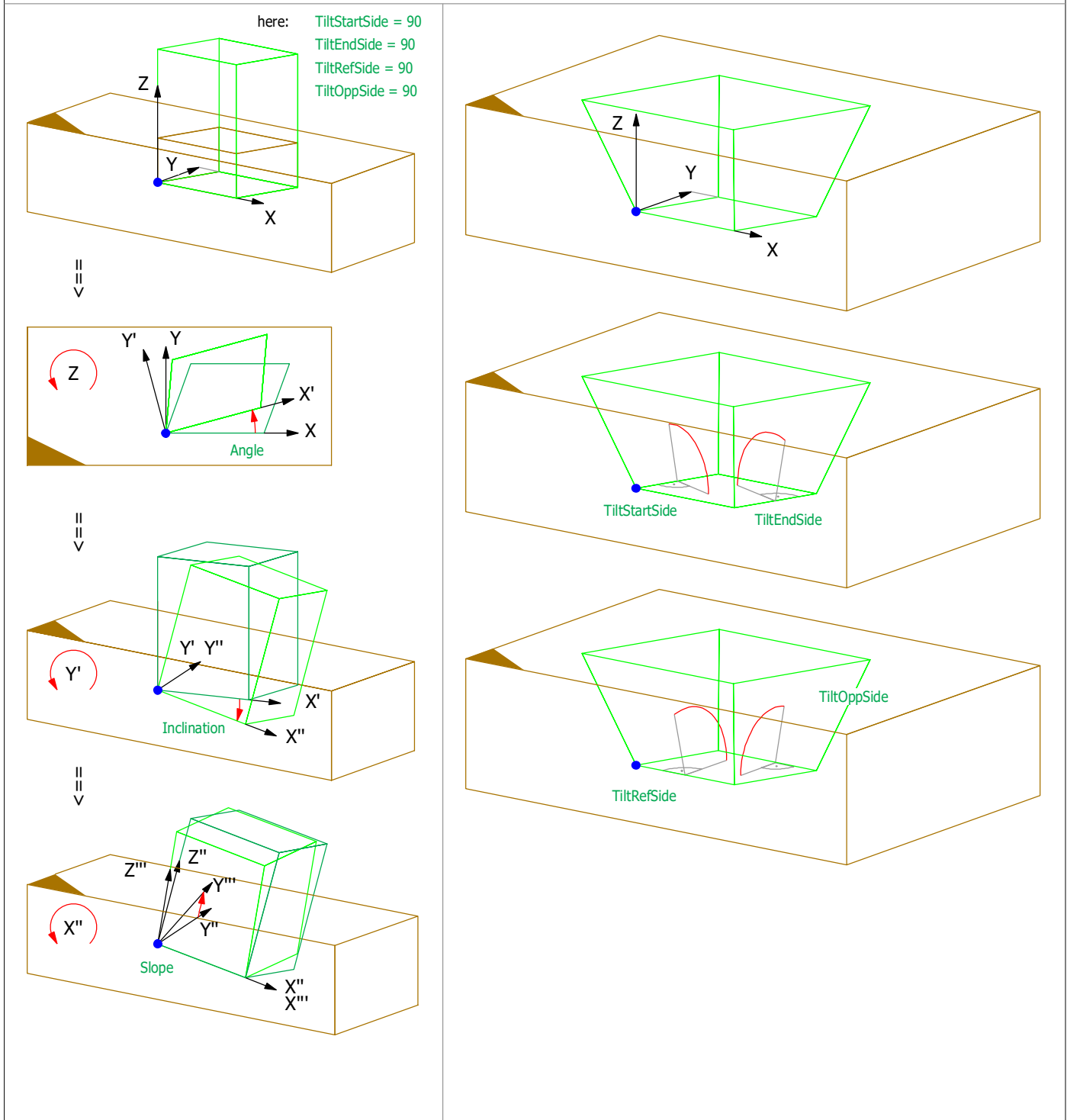
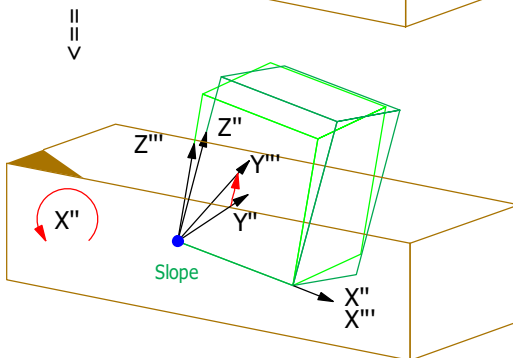
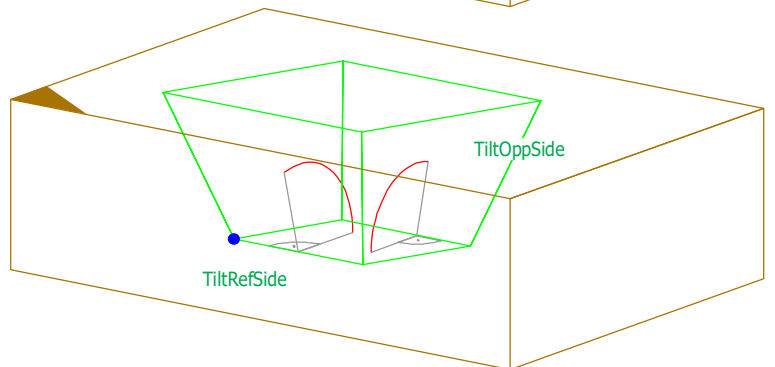
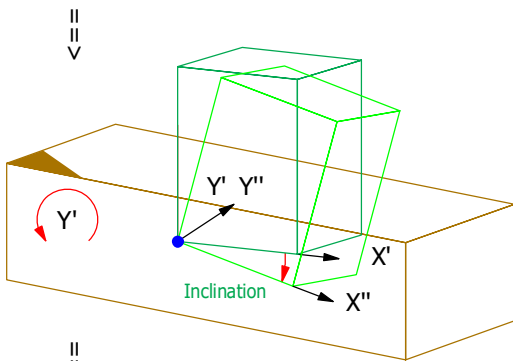
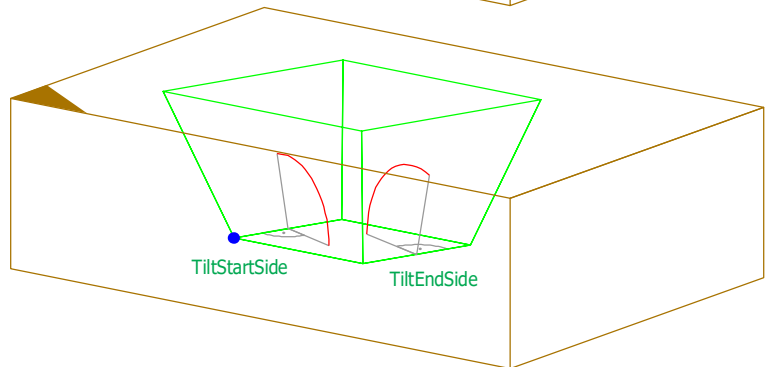
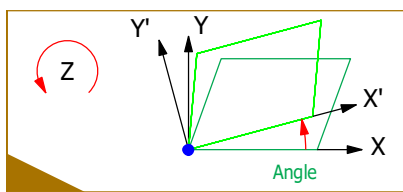
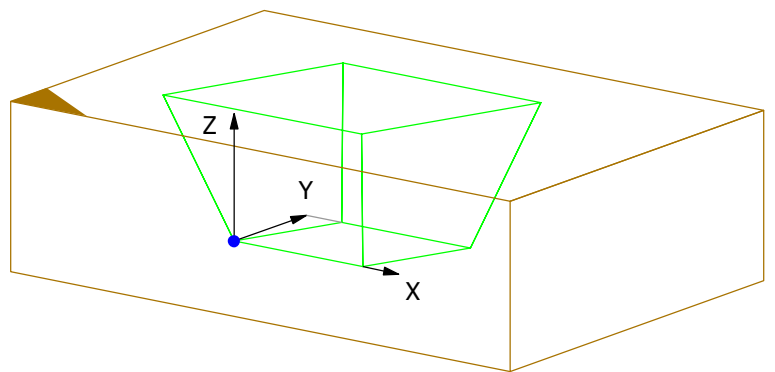
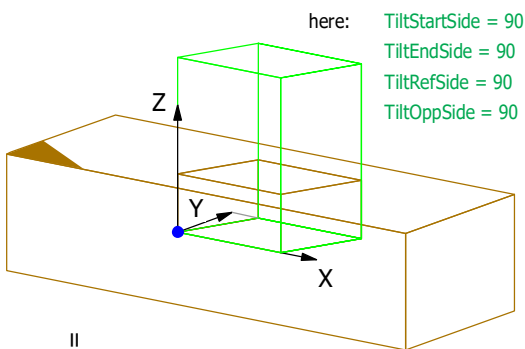
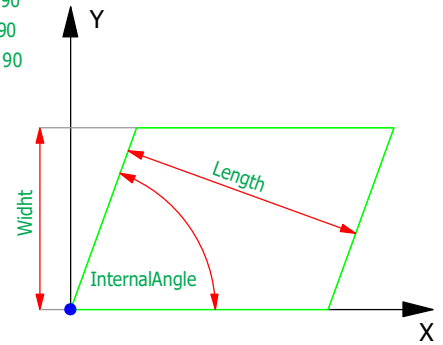
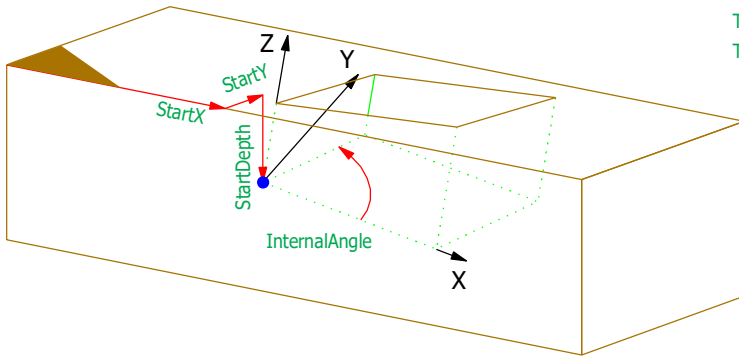

Parameters Pocket

Name	Type	Default	Min	Max
StartX	LengthPosType	0.0	-100000.0	100000.0
StartY	WidthNType	0.0	-50000.0	50000.0
StartDepth	WidthNType	0.0	-50000.0	50000.0
Angle	AngleNType	0.0	-179.9	179.9
Inclination	AngleNType	0.0	-179.9	179.9
Slope	AngleNType	0.0	-179.9	179.9
Length	LengthType	200.0	0.0	100000.0
Width	WidthType	50.0	0.0	50000.0
InternalAngle	AngleType	90.0	0.1	179.9
TiltRefSide	AngleType	90.0	0.1	179.9
TiltEndSide	AngleType	90.0	0.1	179.9
TiltOppSide	AngleType	90.0	0.1	179.9
TiltStartSide	AngleType	90.0	0.1	179.9
MachiningLimits	MachiningLimitType			

MachiningLimits

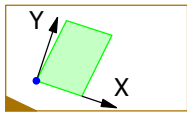

FaceLimitedStart = yes  
 FaceLimitedEnd = yes  
 FaceLimitedFront = yes  
 FaceLimitedBack = yes

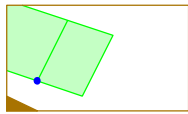

FaceLimitedStart = no  
 FaceLimitedEnd = yes  
 FaceLimitedFront = yes  
 FaceLimitedBack = yes

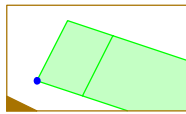

FaceLimitedStart = yes  
 FaceLimitedEnd = no  
 FaceLimitedFront = yes  
 FaceLimitedBack = yes

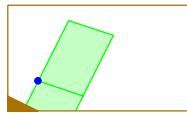

FaceLimitedStart = yes  
 FaceLimitedEnd = yes  
 FaceLimitedFront = no  
 FaceLimitedBack = yes

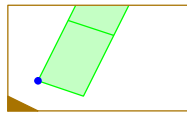

FaceLimitedStart = yes  
 FaceLimitedEnd = yes  
 FaceLimitedFront = yes  
 FaceLimitedBack = no

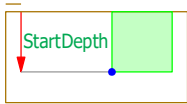

FaceLimitedBottom = yes  
 FaceLimitedTop = no

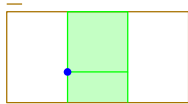

FaceLimitedBottom = no  
 FaceLimitedTop = no

Other combinations of MachineLimits

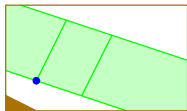

FaceLimitedStart = no  
 FaceLimitedStart = no  
 FaceLimitedFront = no  
 FaceLimitedBack = yes

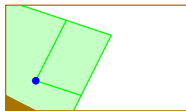

FaceLimitedStart = no  
 FaceLimitedStart = yes  
 FaceLimitedFront = no  
 FaceLimitedBack = yes

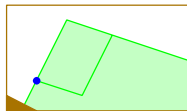

FaceLimitedStart = yes  
 FaceLimitedStart = no  
 FaceLimitedFront = no  
 FaceLimitedBack = yes

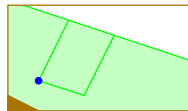

FaceLimitedStart = no  
 FaceLimitedStart = no  
 FaceLimitedFront = no  
 FaceLimitedBack = yes

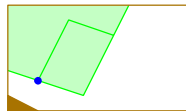

FaceLimitedStart = no  
 FaceLimitedStart = yes  
 FaceLimitedFront = yes  
 FaceLimitedBack = no

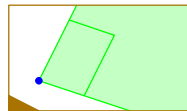

FaceLimitedStart = yes  
 FaceLimitedStart = no  
 FaceLimitedFront = yes  
 FaceLimitedBack = no

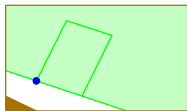

FaceLimitedStart = no  
 FaceLimitedStart = no  
 FaceLimitedFront = yes  
 FaceLimitedBack = no

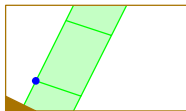

FaceLimitedStart = yes  
 FaceLimitedStart = yes  
 FaceLimitedFront = no  
 FaceLimitedBack = no

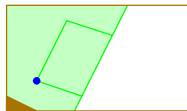

FaceLimitedStart = no  
 FaceLimitedStart = yes  
 FaceLimitedFront = no  
 FaceLimitedBack = no

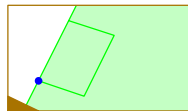

FaceLimitedStart = yes  
 FaceLimitedStart = no  
 FaceLimitedFront = no  
 FaceLimitedBack = no

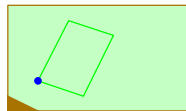

FaceLimitedStart = no  
 FaceLimitedStart = no  
 FaceLimitedFront = no  
 FaceLimitedBack = no

### Drilling

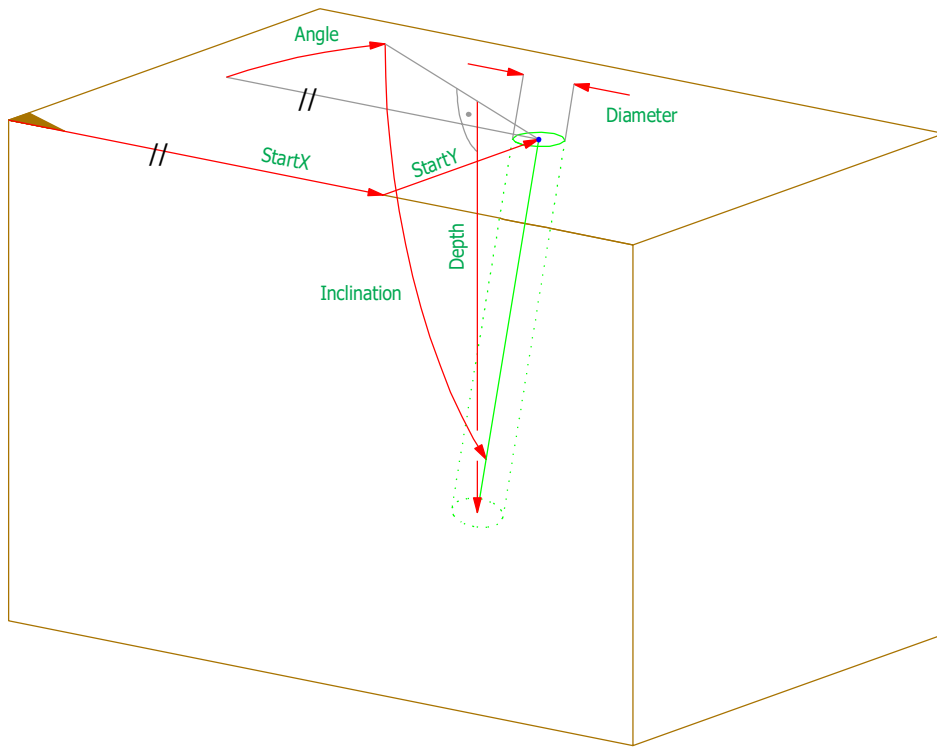

DepthLimited = yes

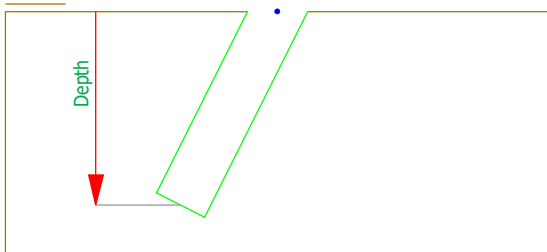

DepthLimited = no

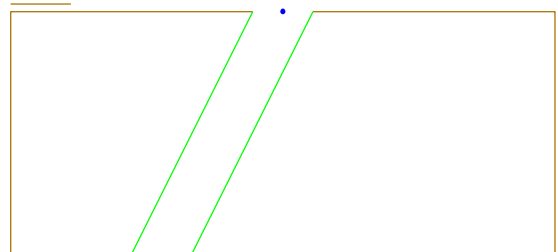

## Parameters Drilling

Name	Type	Default	Min	Max
StartX	LengthPosType	0.0	-100000.0	100000.0
StartY	WidthNType	0.0	-50000.0	50000.0
Angle	Angle3Type	0	0.0	360.0
Inclination	AngleType	90.0	0.1	179.9
DepthLimited	BooleanType	no	no	yes
Depth	WidthType	50.0	0.0	50000.0
Diameter	DiameterType	20.0	0.0	50000.0



### Tenon

Orientation = start

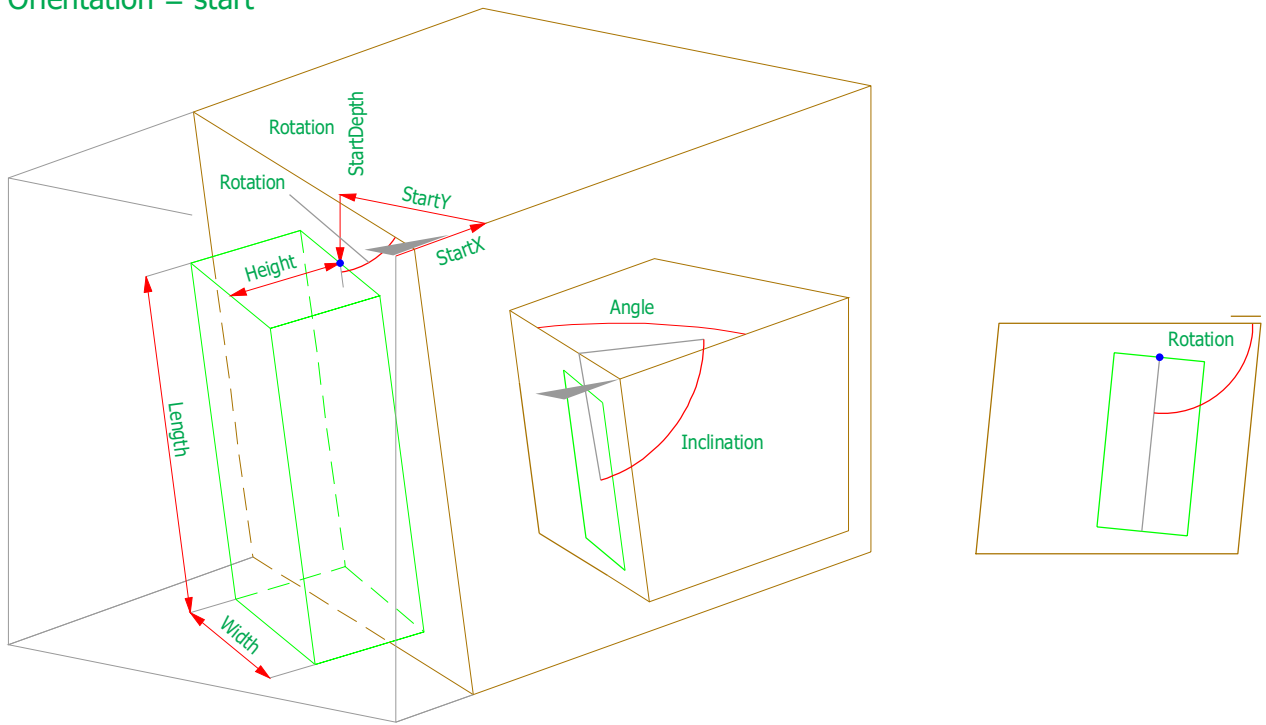

Orientation = start

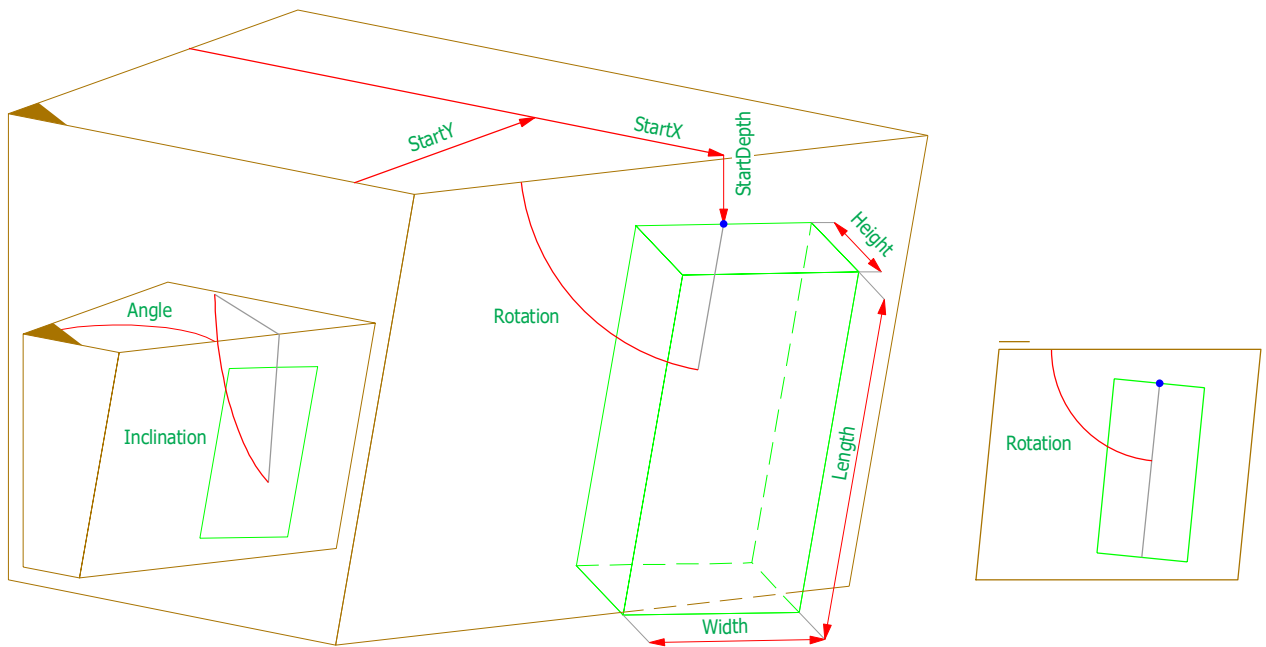

Chamfer = no

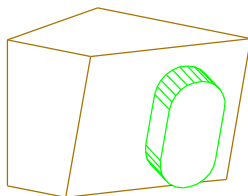

Chamfer = yes

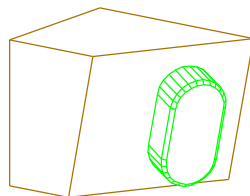

Parameters Tenon

Name	Type	Default	Min	Max
Orientation	OrientationType		start	end
StartX	LengthPosType	0.0	-100000.0	100000.0
StartY	WidthNType	50.0	-50000.0	50000.0
StartDepth	WidthNType	50.0	-50000.0	50000.0
Angle	AngleType	90.0	0.1	179.9
Inclination	AngleType	90.0	0.1	179.9
Rotation	AngleType	90.0	0.1	179.9
LengthLimitedTop	BooleanType	yes	no	yes
LengthLimitedBottom	BooleanType	yes	no	yes
Length	WidthType	80.0	0.0	50000.0
Width	LengthSType	40.0	0.0	1000.0
Height	LengthSType	40.0	0.0	1000.0
Shape	TenonShapeType	automatic		
ShapeRadius	LengthSType	20.0	0.0	1000.0
Chamfer	BooleanType	no	no	yes

Shape = automatic

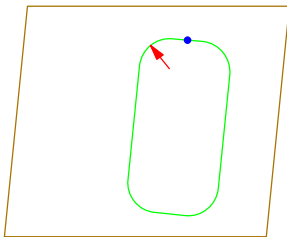

Shape = square

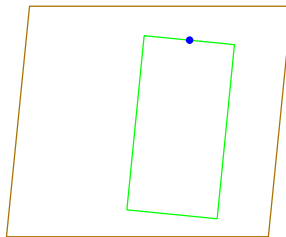

Shape = round

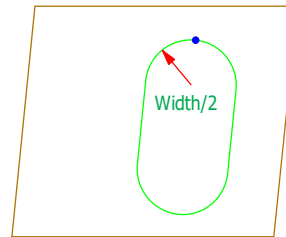

The tenon can be square, round or machine defined depending on the capabilities of the machine.

Shape = rounded

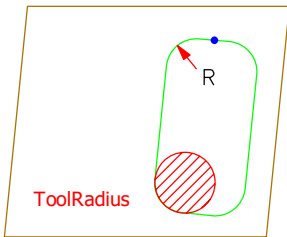

Shape = radius

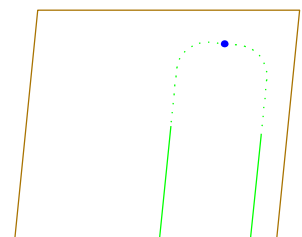
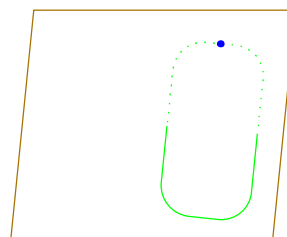
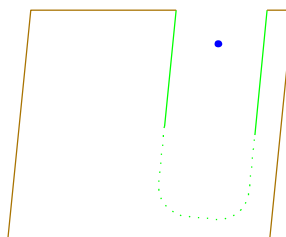
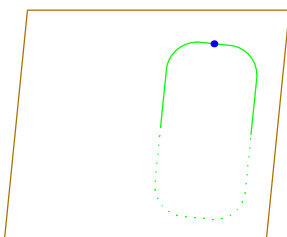
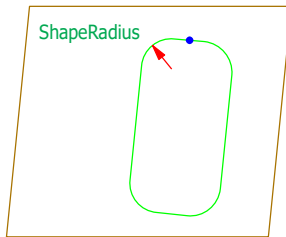

Mortise

Orientation = start

①

Inclination = 90  
Slope = 90

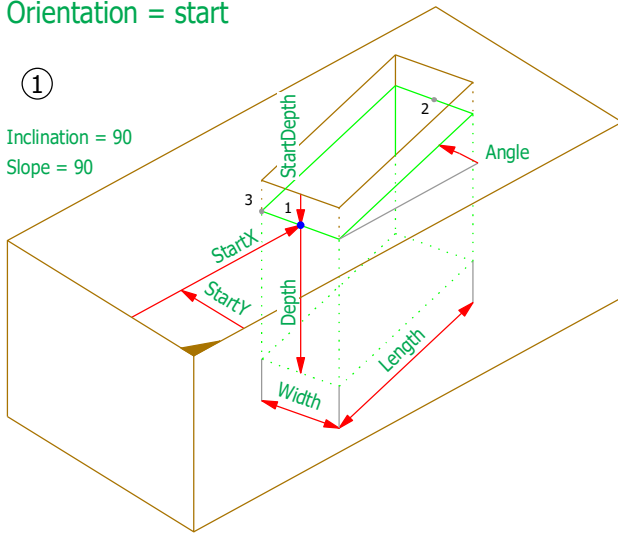

Inclination = 90  
Slope = 90 - rotation(1-3)

||  
||  
v  
②

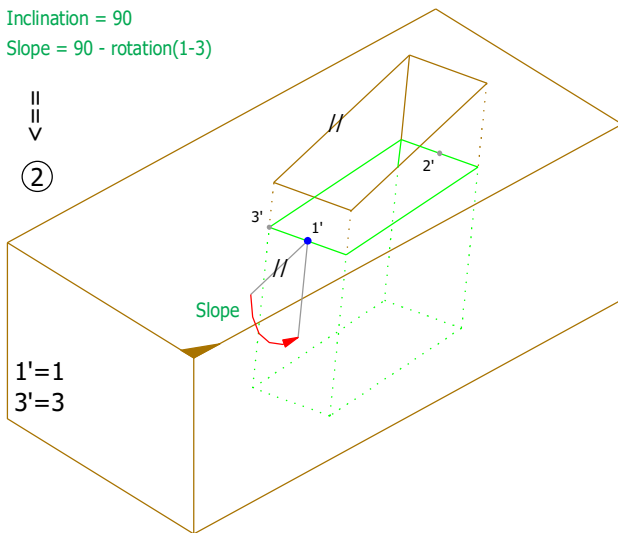

1'=1  
3'=3

Inclination = 90 - rotation(1'-2')

||  
||  
v  
③

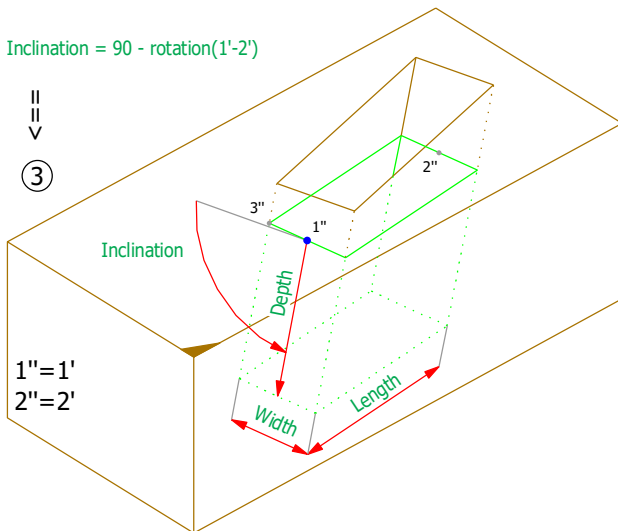

1''=1'  
2''=2'

Parameters Mortise

Name	Type	Default	Min	Max
StartX	LengthPosType	0.0	-100000.0	100000.0
StartY	WidthNType	50.0	-50000.0	50000.0
StartDepth	WidthType	0.0	0.0	50000.0
Angle	Angle2NType	0.0	-180.0	180.0
Inclination	AngleType	90.0	0.1	179.9
Slope	AngleType	90.0	0.1	179.9
LengthLimitedTop	BooleanType	yes	no	yes
LengthLimitedBottom	BooleanType	yes	no	yes
Length	WidthType	80.0	0.0	50000.0
Width	LengthSType	40.0	0.0	1000.0
Depth	LengthSType	40.0	0.0	1000.0
Shape	TenonShapeType	automatic		
ShapeRadius	LengthSType	20.0	0.0	1000.0

Shape = automatic

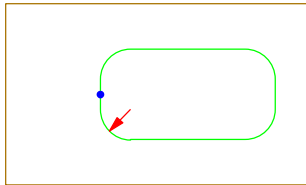

Shape = square

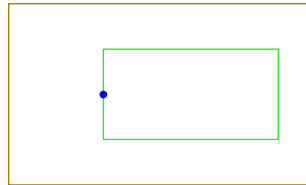

Shape = round

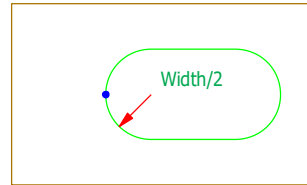

The mortise can be square, round or machine defined, depending on the capabilities of the machine.

Shape = rounded

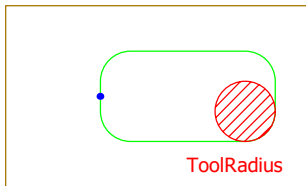

Shape = radius

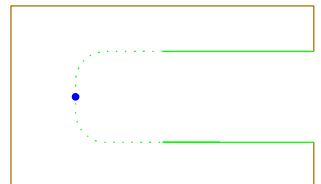
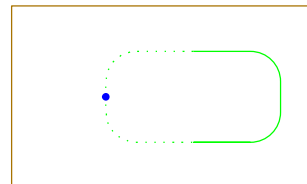
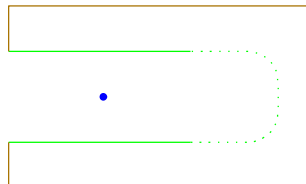
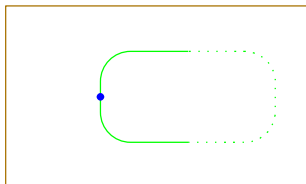
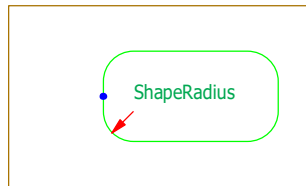

# House

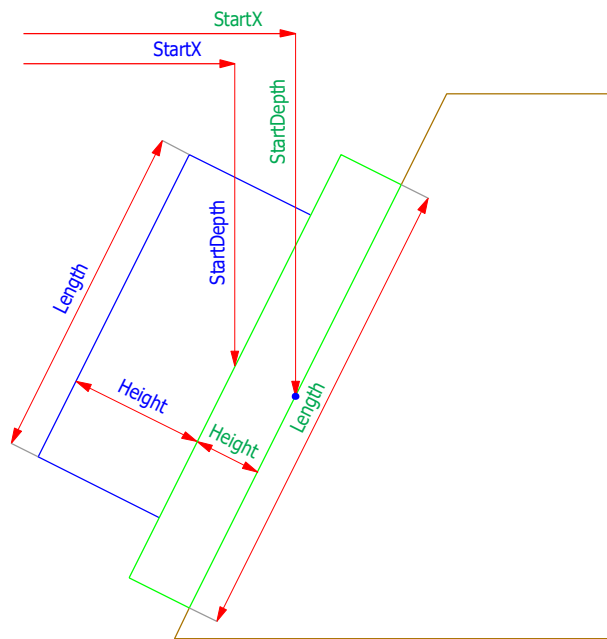
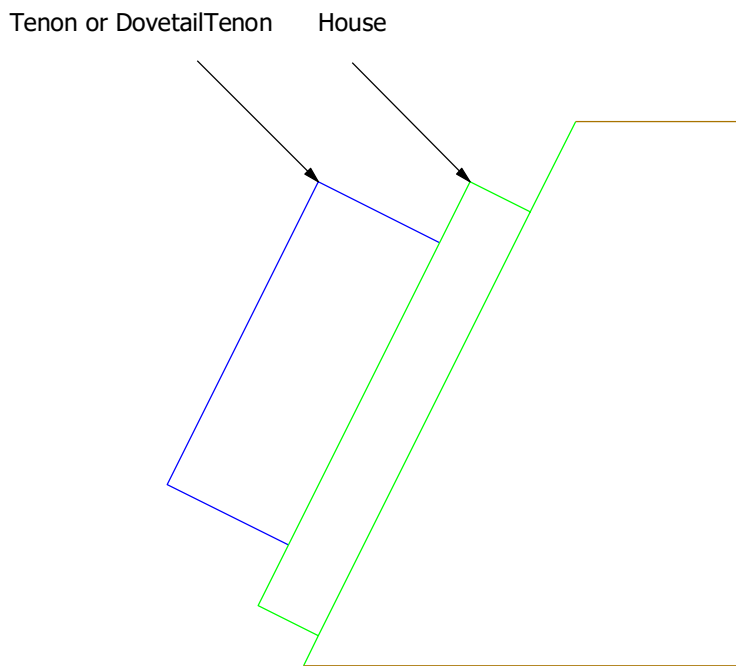

green: Parameters for House.  
blue: Parameters for Tenon or DovetailTenon

## Parameters House

The House has same parameters as the Tenon.

# HouseMortise

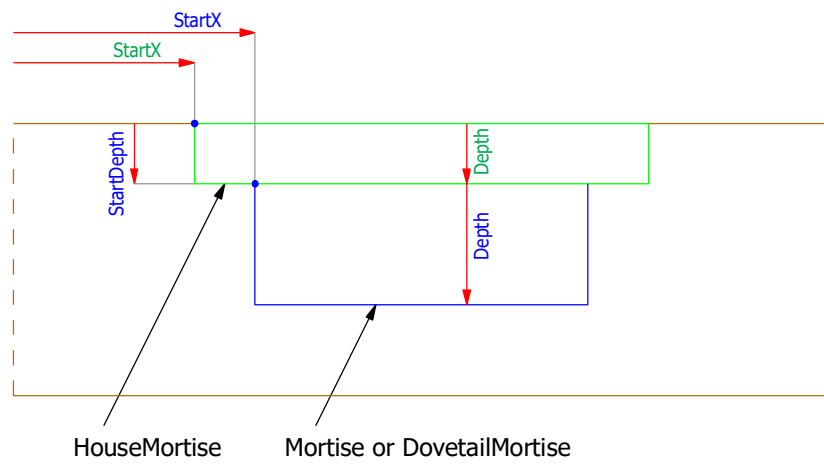

## Parameters HouseMortise

The HouseMortise has same parameters as the Mortise.



### DovetailTenon

Orientation = start

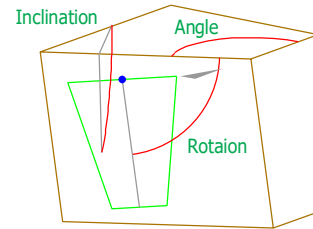
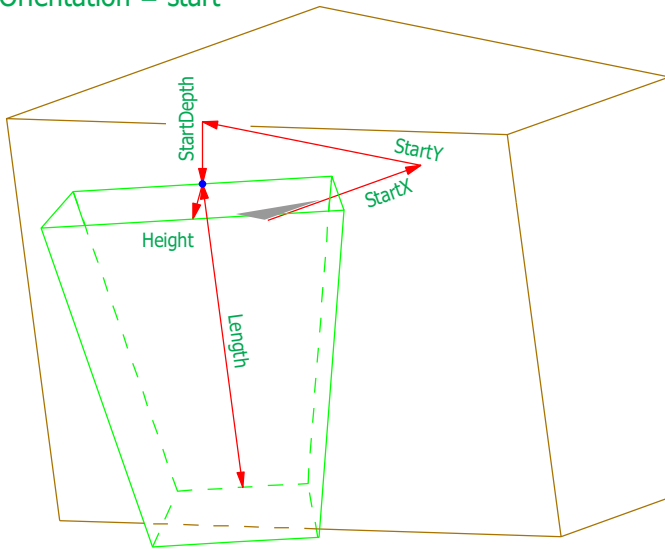

Orientation = end

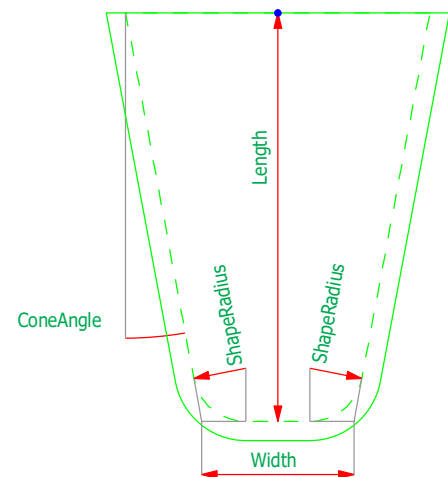
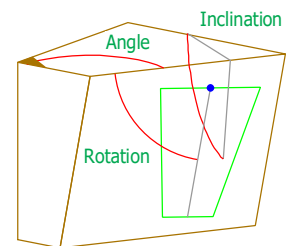
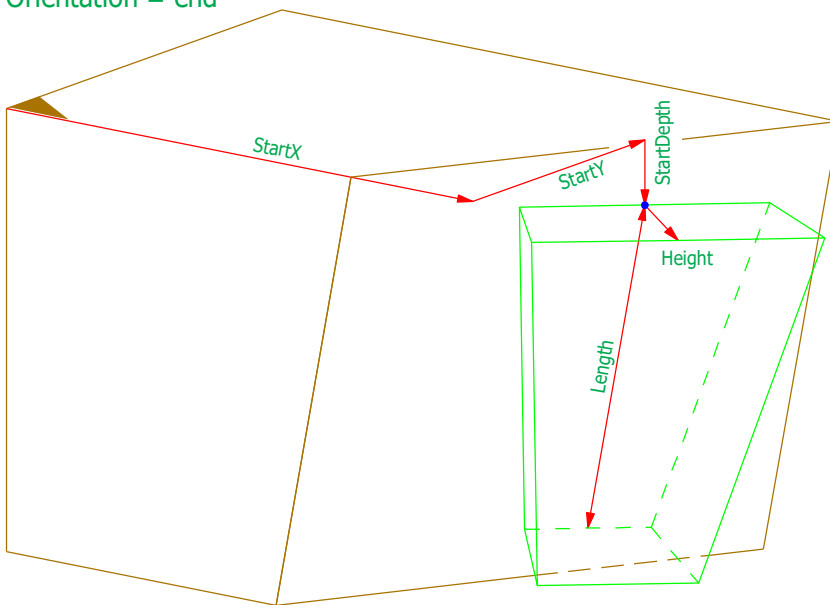

Parameters DovetailTenon

Name	Type	Default	Min	Max
Orientation	OrientationType		start	end
StartX	LengthPosType	0.0	-100000.0	100000.0
StartY	WidthNType	50.0	-50000.0	50000.0
StartDepth	WidthNType	50.0	-50000.0	50000.0
Angle	AngleType	90.0	0.1	179.9
Inclination	AngleType	90.0	0.1	179.9
Rotation	AngleType	90.0	0.1	179.9
LengthLimitedTop	BooleanType	yes	no	yes
LengthLimitedBottom	BooleanType	yes	no	yes
Length	WidthType	80.0	0.0	50000.0
Width	LengthSType	40.0	0.0	1000.0
Height	LengthSType	28.0	0.0	1000.0
ConeAngle	double		0.0	30.0
UseFlankAngle	BooleanType	no	no	yes
FlankAngle	double	15.0	5.0	35.0
Shape	TenonShapeType	automatic		
ShapeRadius	LengthSType	20.0	0.0	1000.0

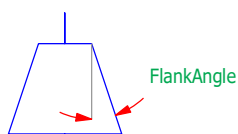
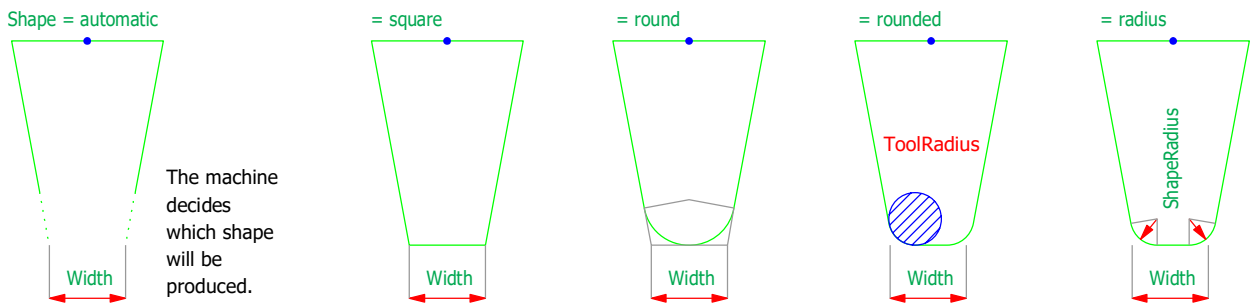
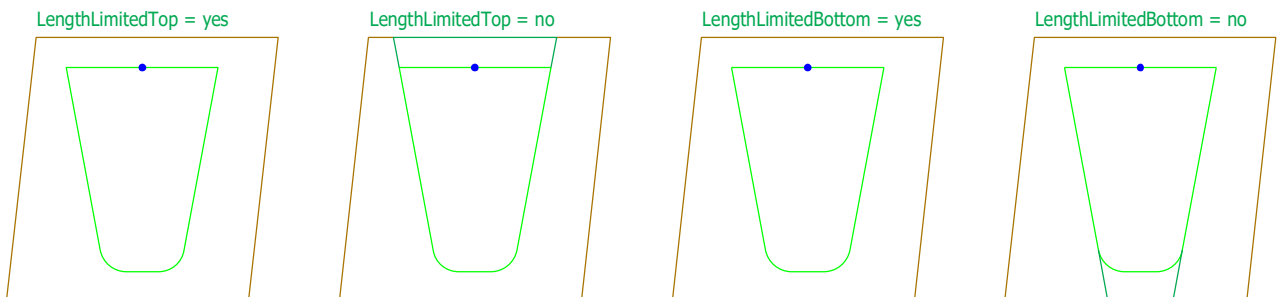

UseFlankAngle = no:  
Shape of dovetail must be done with FlankAngle of the tool from machine.

UseFlankAngle = yes:  
Shape of dovetail must be done with the parameter FlankAngle

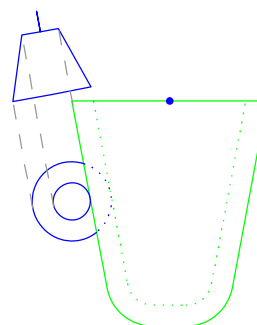

### DovetailMortise

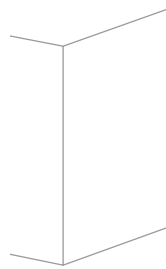
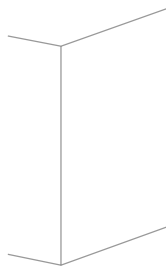
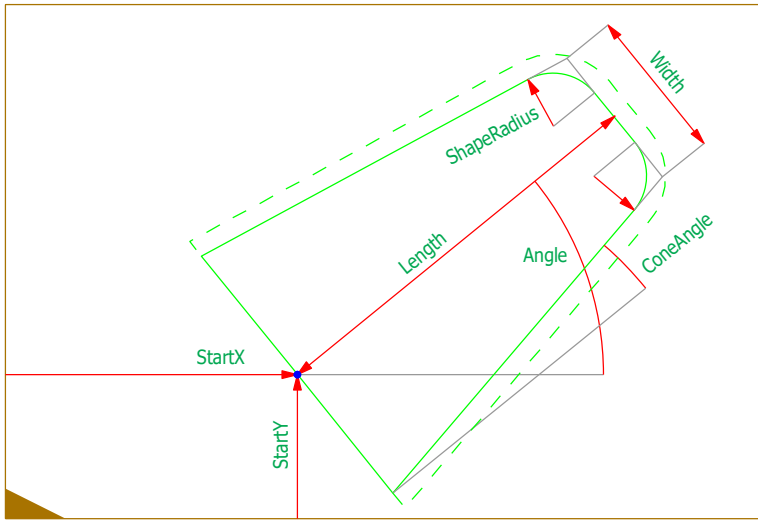

Parameters DovetailMortise

Name	Type	Default	Min	Max
StartX	LengthPosType	0.0	-100000.0	100000.0
StartY	WidthNType	50.0	-50000.0	50000.0
StartDepth	WidthType	0.0	0.0	50000.0
Angle	Angle2NType	0.0	-180.0	180.0
Inclination	AngleType	90.0	0.1	179.9
Slope	AngleType	90.0	0.1	179.9
LimitationTop	LimitationTopType	limited		
LengthLimitedBottom	BooleanType	yes	no	yes
Length	WidthType	80.0	0.0	50000.0
Width	LengthSType	40.0	0.0	1000.0
Depth	LengthSType	28.0	0.0	1000.0
ConeAngle	double		0.0	30.0
UseFlankAngle	BooleanType	no	no	yes
FlankAngle	double	15.0	5.0	35.0
Shape	TenonShapeType	automatic		
ShapeRadius	LengthSType	20.0	0.0	1000.0

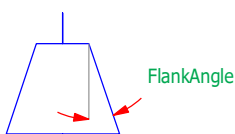
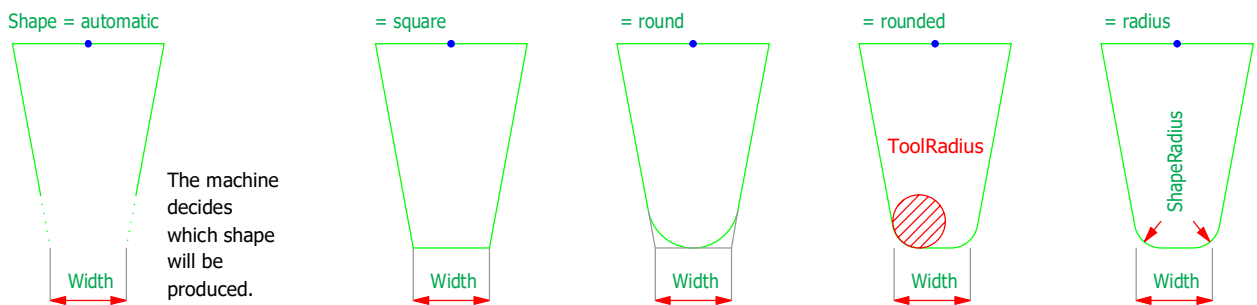
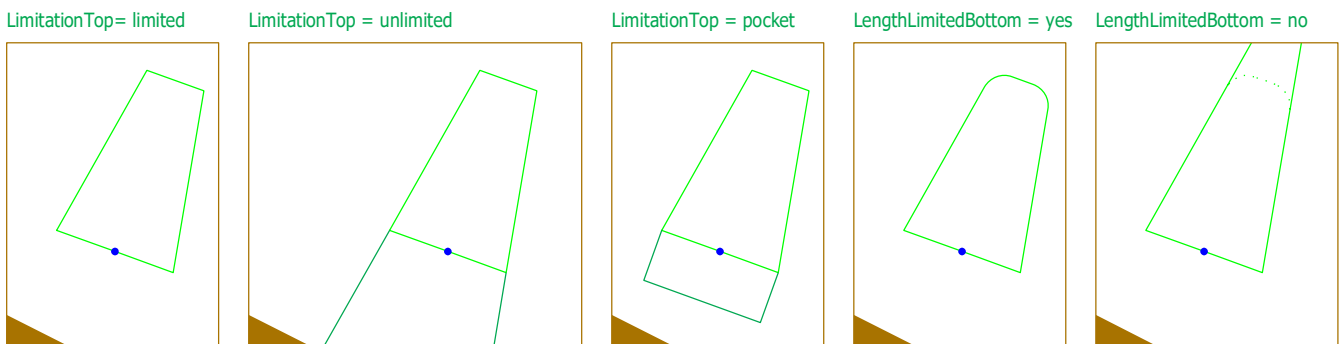

UseFlankAngle = no:  
 Shape of dovetail must be done with FlankAngle of the tool from machine.

UseFlankAngle = yes:  
 Shape of dovetail must be done with the parameter FlankAngle

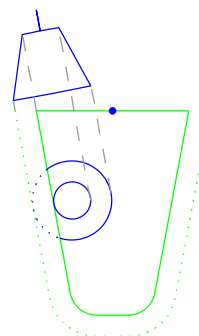

### Marking

MarkingStyle = single

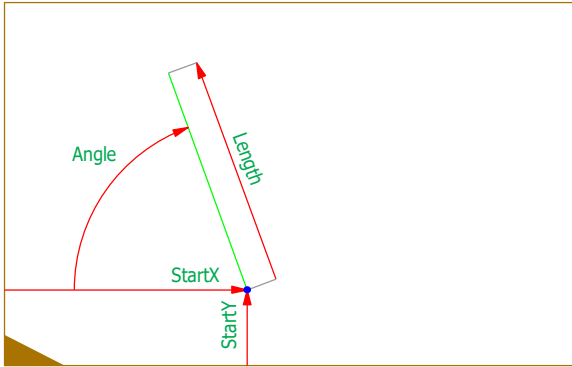

MarkingStyle = double

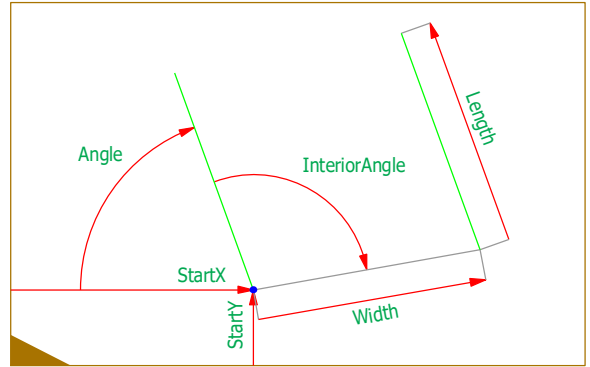

MarkingStyle = square

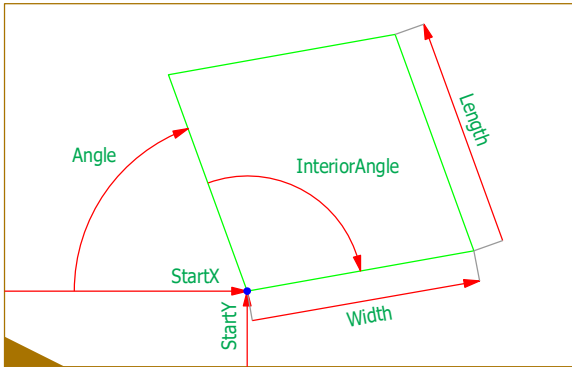

## Parameters Marking

Name	Type	Default	Min	Max
StartX	LengthPosType	0.0	-100000.0	100000.0
StartY	WidthNType	0.0	-50000.0	50000.0
Angle	Angle2NType	0	-180.0	180.0
LengthLimited	BooleanType	no	no	yes
Length	WidthType	20.0	0.0	50000.0
Width	WidthType	100.0	0.0	50000.0
InteriorAngle	AngleType	90.0	0.1	179.9
Style	MarkingStyleType	single	single/double/square	

Text

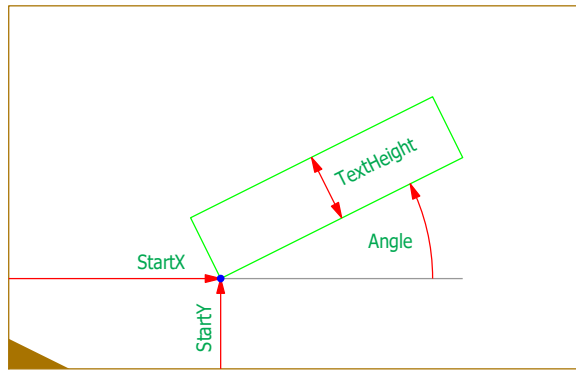

Text = "ABCD"

		AlignmentHorizontal		
		left	center	right
AlignmentVertical	bottom			
	center			
	top			

Text = "ABCD\nEF\nGHI"

AlignmentMultiline				
		left	center	right

StackedMarking	
no	yes

## Parameters Text

Name	Type	Default	Min	Max
StartX	LengthPosType	0	-100000	100000
StartY	WidthNType	0	-50000	50000
Angle	Angle2NType	0	-180	180
AlignmentVertical	AlignmentVerticalType	bottom		
AlignmentHorizontal	AlignmentHorizontalType	left		
AlignmentMultiline	AlignmentHorizontalType	left		
StackedMarking	BooleanType	no	no	yes
TextHeightAuto	BooleanType	yes	no	yes
TextHeight	WidthType	20	0	50000
Text	xs:string			



### SimpleScarf

Orientation = start

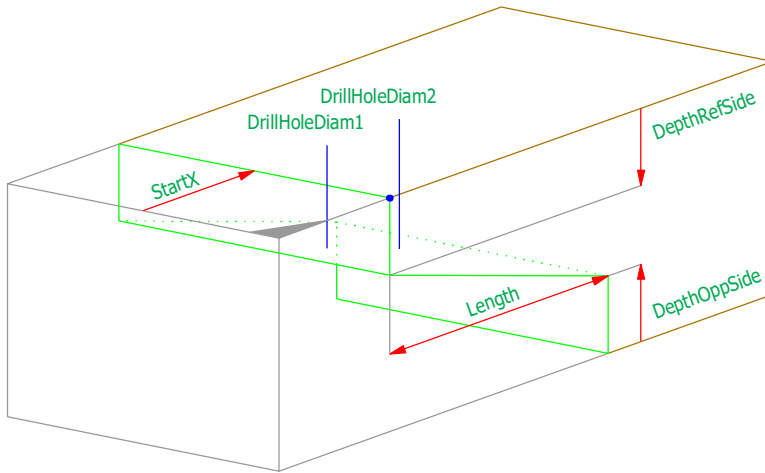

Orientation = end

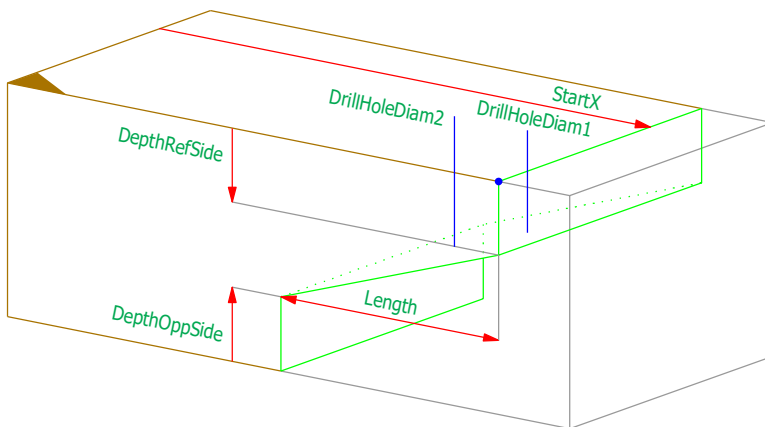

## Parameters SimpleScarf

Name	Type	Default	Min	Max
Orientation	OrientationType		start	end
StartX	LengthPosType	0.0	-100000.0	100000.0
Length	WidthType	200.0	0.0	50000.0
DepthRefSide	WidthType	20.0	0.0	50000.0
DepthOppSide	WidthType	20.0	0.0	50000.0
NumDrillHole	byte	0	0	2
DrillHoleDiam1	LengthSType	20.0	0.0	1000.0
DrillHoleDiam2	LengthSType	20.0	0.0	1000.0

### ScarfJoint

Orientation = start

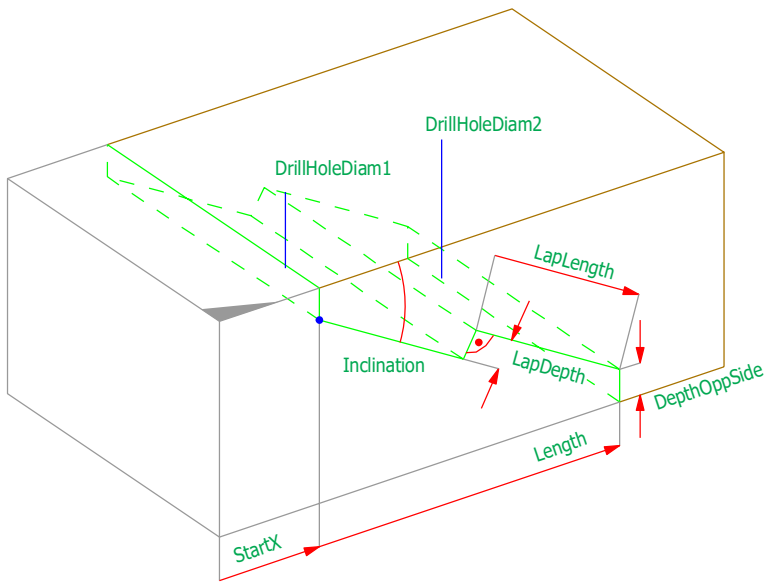

ScarfShape = classic

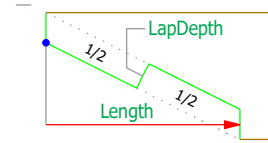

ScarfShape = refsided

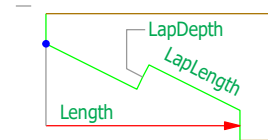

ScarfShape = baseside

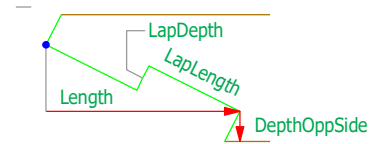

Orientation = end

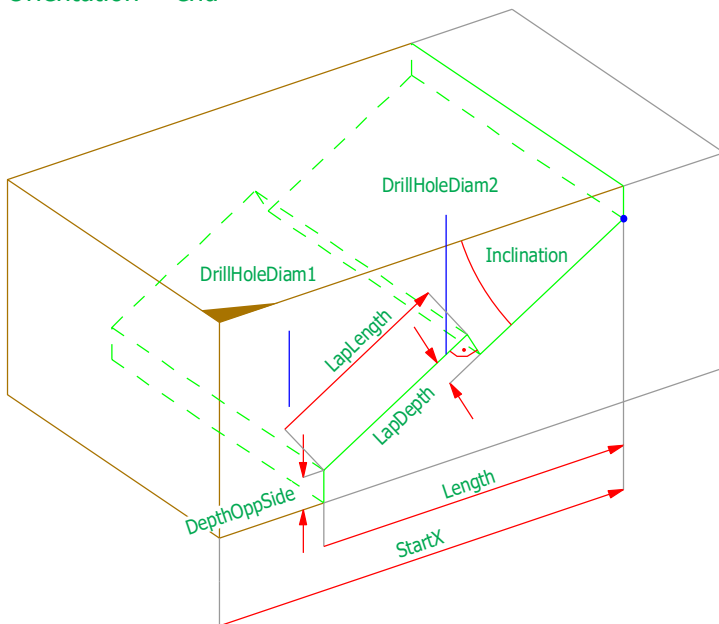

ScarfShape = classic

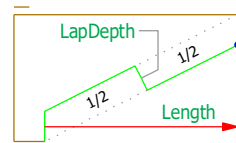

ScarfShape = refsided

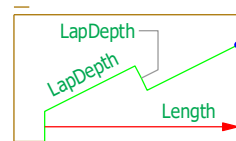

ScarfShape = baseside

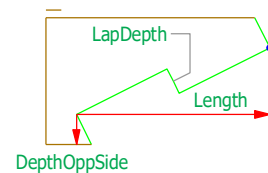

## Parameters ScarfJoint

Name	Type	Default	Min	Max
Orientation	OrientationType		start	end
StartX	LengthPosType	0.0	-100000.0	100000.0
Inclination	Inclination3Type		0.0	90.0
LapLength	WidthType	100.0	0.0	50000.0
LapDepth	WidthType	20.0	0.0	50000.0
Length	WidthType	200.0	0.0	50000.0
DepthOppSide	WidthType	20.0	0.0	50000.0
ScarfShape	ScarfShapeType	refside		
NumDrillHole	byte	0	0	2
DrillHoleDiam1	LengthSType	20.0	0.0	1000.0
DrillHoleDiam2	LengthSType	20.0	0.0	1000.0

### StepJoint

Orientation = start

Orientation = end

Tenon = no

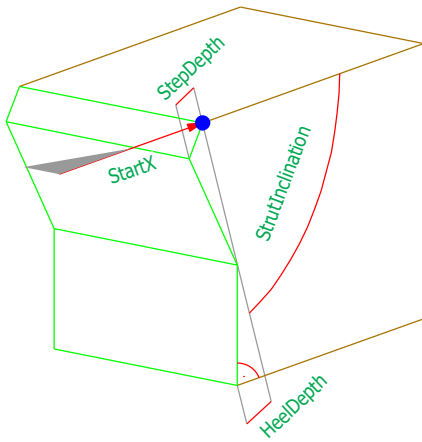

StepShape = double

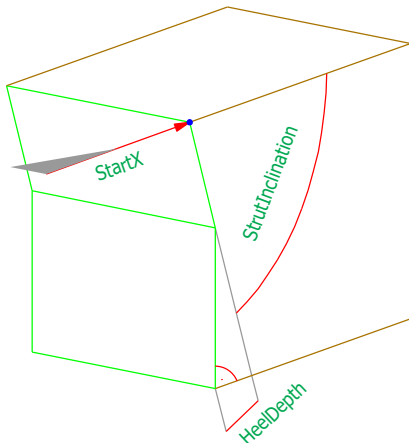
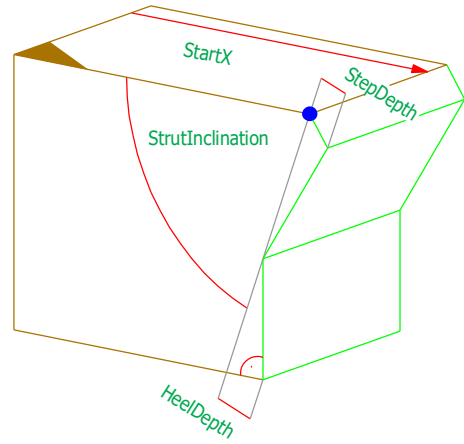

StepShape = step

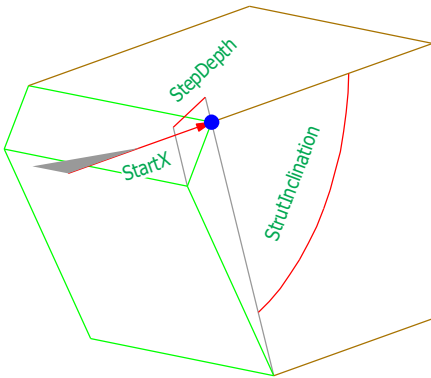
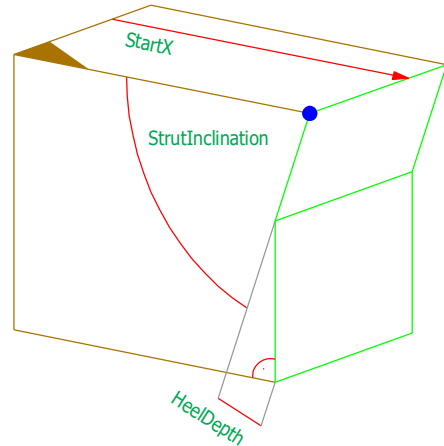

StepShape = heel

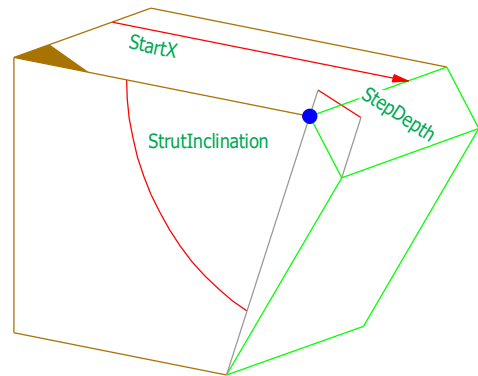

Tenon = yes

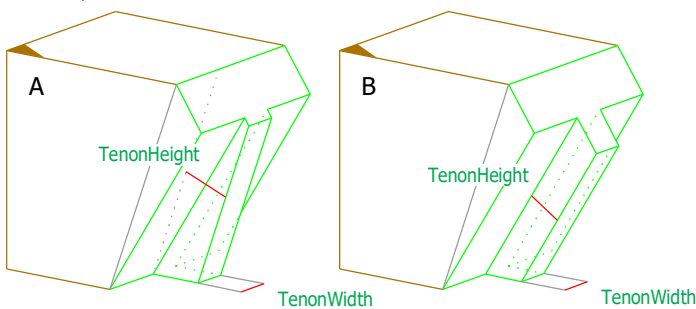

Which style (A or B) is used depends on the machine

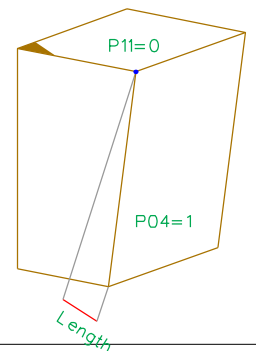
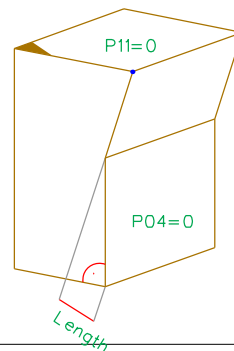

## Parameters StepJoint

Name	Type	Default	Min	Max
Orientation	OrientationType		start	end
StartX	LengthPosType	0.0	-100000.0	100000.0
StrutInclination	AngleType		0.1	179.9
StepDepth	WidthType	20.0	0.0	50000.0
HeelDepth	WidthType	20.0	0.0	50000.0
StepShape	StepShapeType	double		
Tenon	BooleanType	no	no	yes
TenonWidth	LengthSType	40.0	0.0	1000.0
TenonHeight	LengthSType	40.0	0.0	1000.0

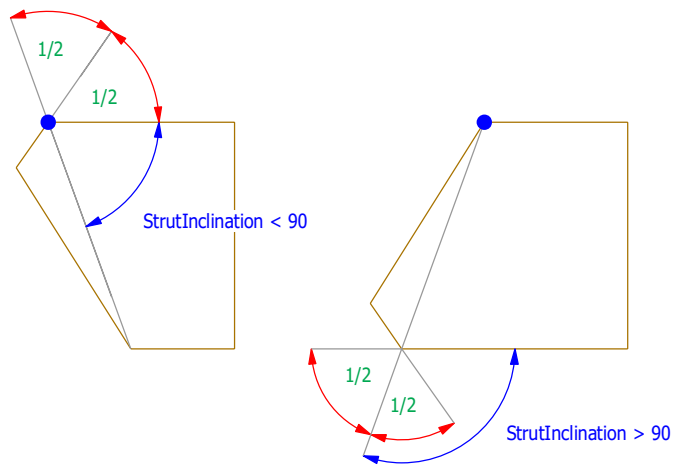

### StepJointNotch

Orientation = start

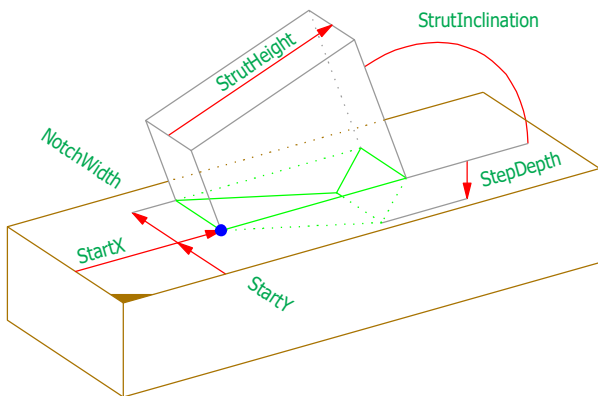

Orientation = end

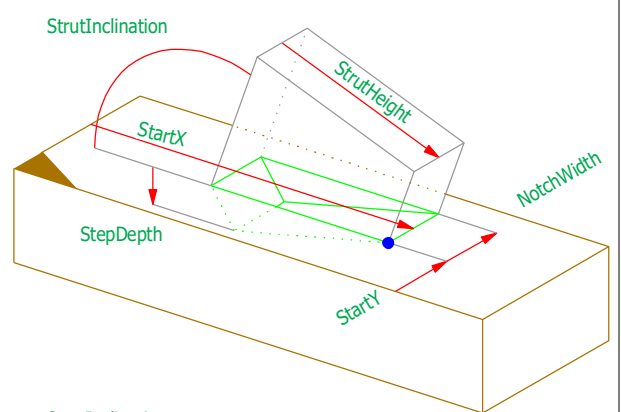

StepShape = step

StepShape = heel

StepShape = double

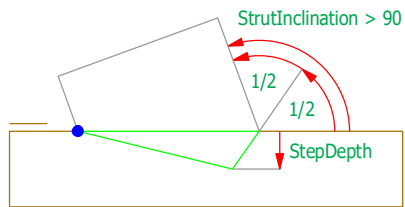
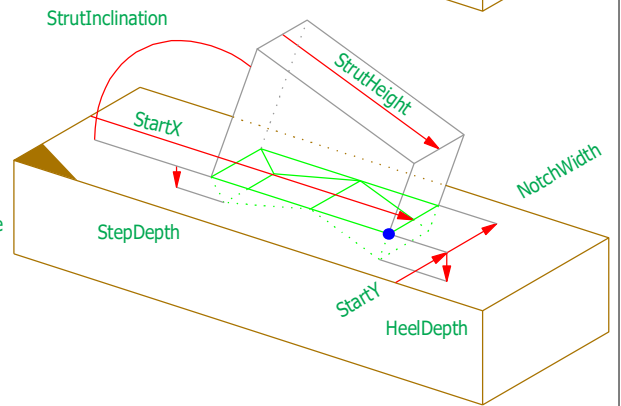
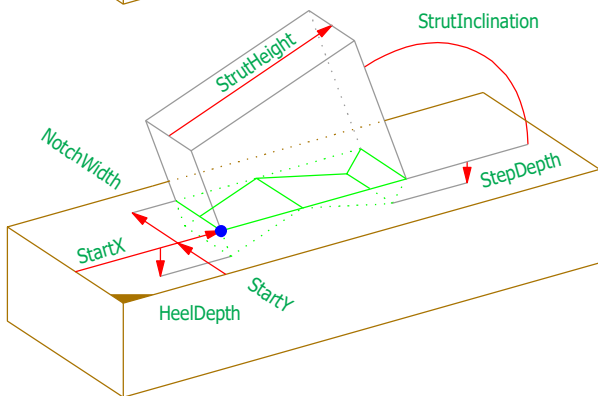
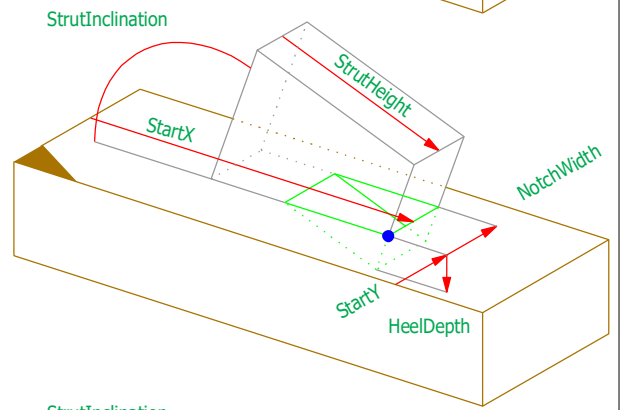
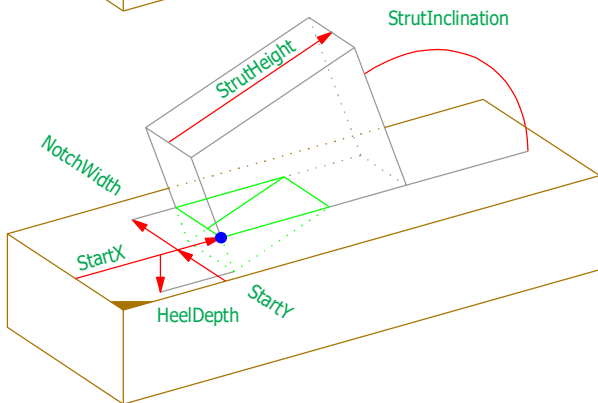

StepShape = step

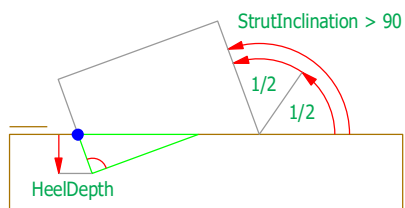
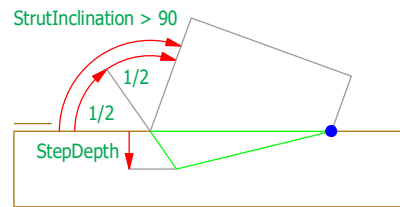

StepShape = heel

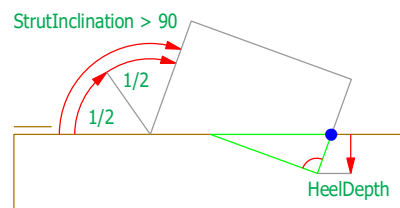

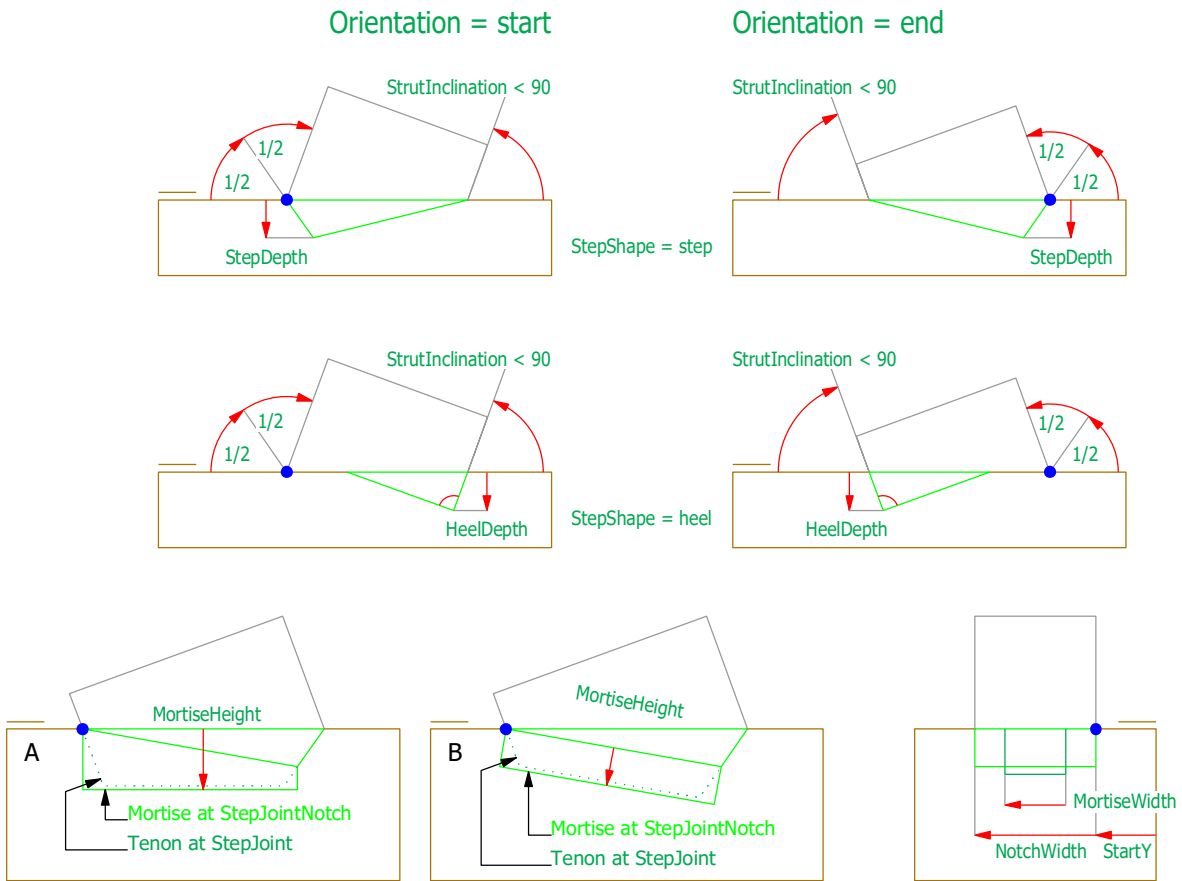

Parameters StepJointNotch

Name	Type	Default	Min	Max
Orientation	OrientationType		start	end
StartX	LengthPosType	0.0	-100000.0	100000.0
StartY	WidthNType	0.0	-50000.0	50000.0
StrutInclination	AngleType		0.1	179.9
NotchLimited	BooleanType	no	no	yes
NotchWidth	WidthType	20.0	0.0	50000.0
StepDepth	WidthType	20.0	0.0	50000.0
HeelDepth	WidthType	20.0	0.0	50000.0
StrutHeight	WidthType	20.0	0.0	50000.0
StepShape	StepShapeType	double		
Mortise	BooleanType	no	no	yes
MortiseWidth	LengthSType	40.0	0.0	1000.0
MortiseHeight	LengthSType	40.0	0.0	1000.0



Planing

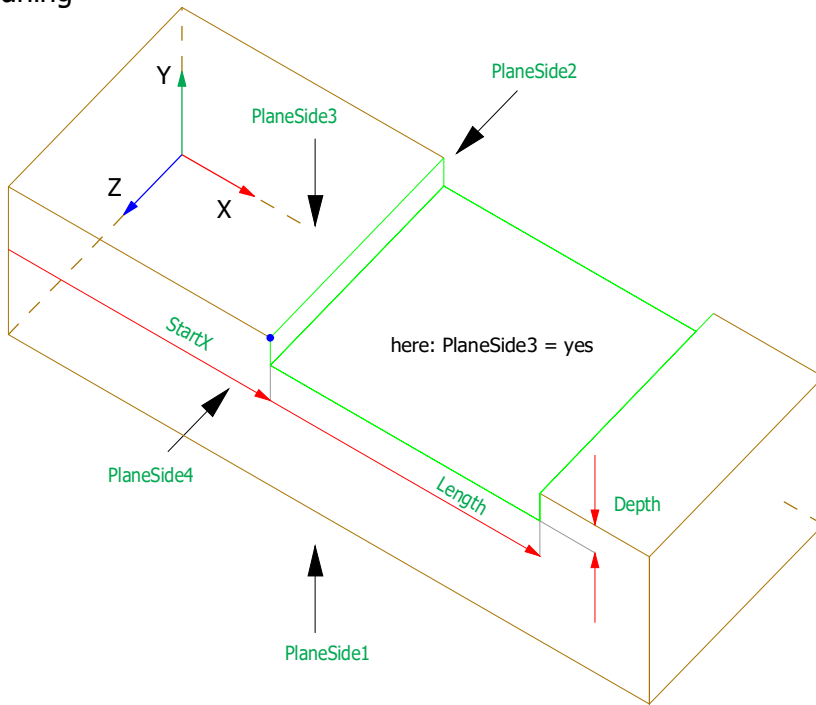

StartLimited	EndLimited	
yes	yes	
no	yes	
yes	no	
no	no	

Examples

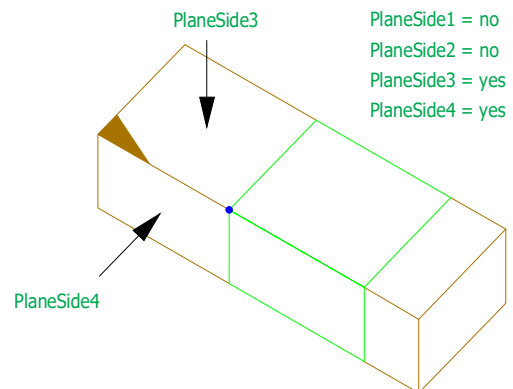
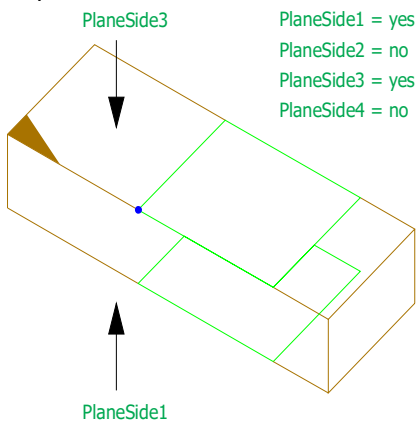

## Parameters Planing

Name	Type	Default	Min	Max
StartX	LengthPosType	0.0	-100000.0	100000.0
Length	LengthType	0.0	0.0	100000.0
Depth	double	1.0	0.0	50.0
StartLimited	BooleanType	no	no	yes
EndLimited	BooleanType	no	no	yes
PlaneSide1	BooleanType	yes	no	yes
PlaneSide2	BooleanType	yes	no	yes
PlaneSide3	BooleanType	yes	no	yes
PlaneSide4	BooleanType	yes	no	yes

### ProfileFront

Orientation = start

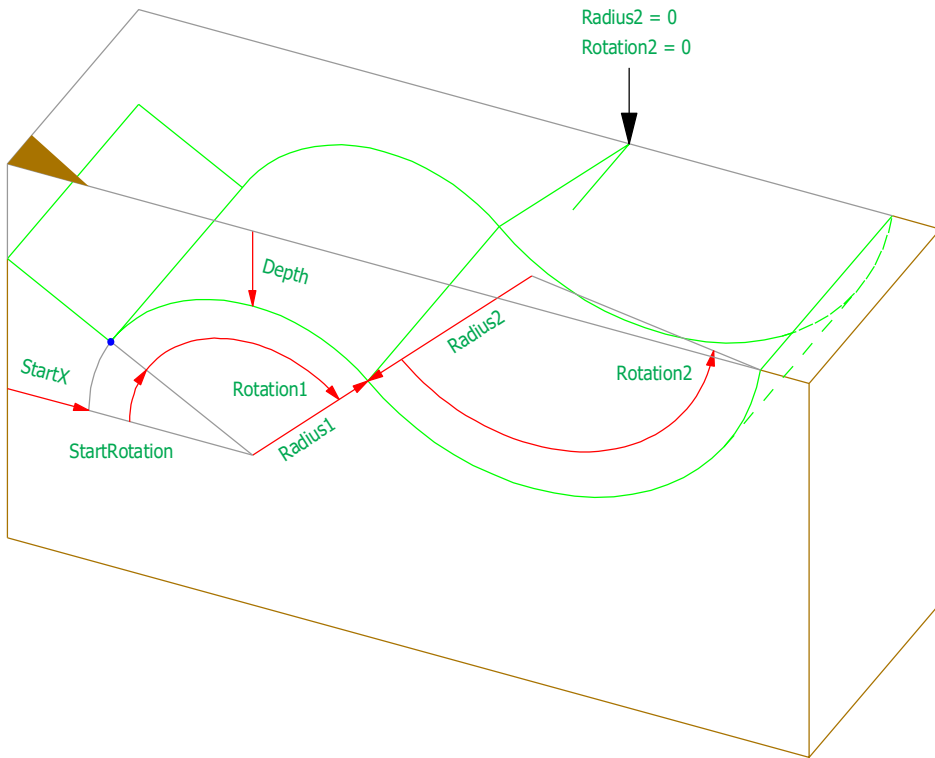

Orientation = end

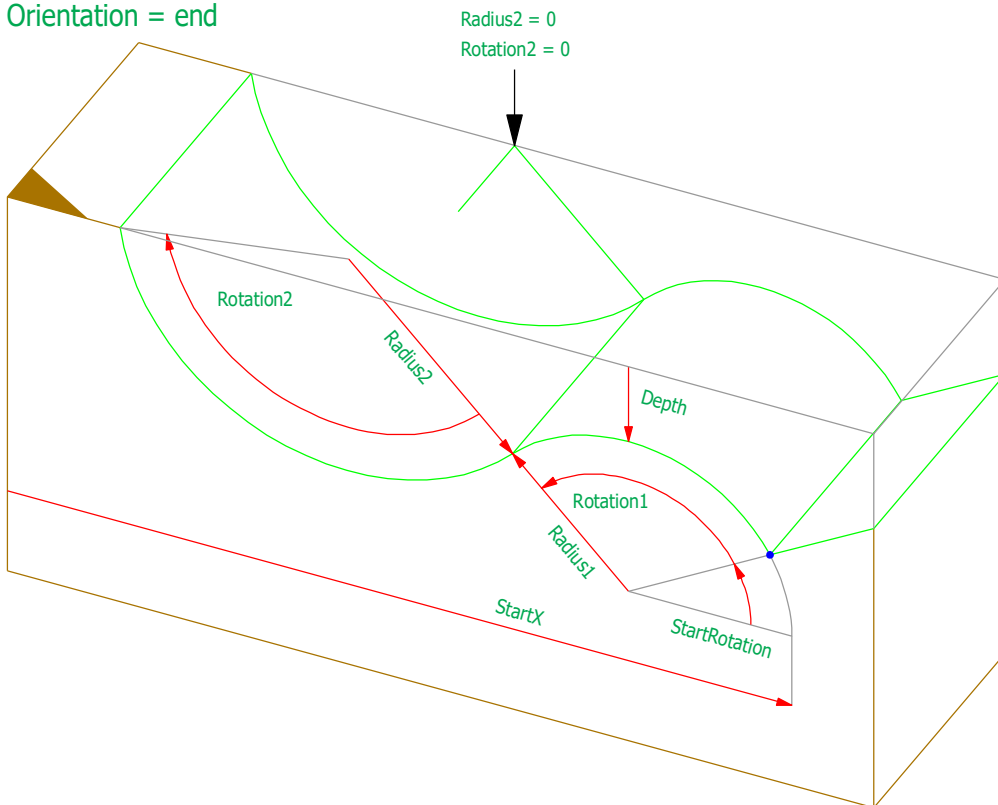

## Parameters ProfileFront

Name	Type	Default	Min	Max
Orientation	OrientationType		start	end
StartX	LengthPosType	0.0	-100000.0	100000.0
ArcShape	ArcShapeType	convex		
Depth	LengthSType	0.0	0.0	1000.0
StartRotation	Inclination2Type	0.0	-90.0	90.0
Rotation1	Angle2Type	90.0	0.0	180.0
Radius1	LengthSType	250.0	0.0	1000.0
Rotation2	Angle2Type	90.0	0.0	180.0
Radius2	LengthSType	250.0	0.0	1000.0

ProfileCambered

Orientation = start

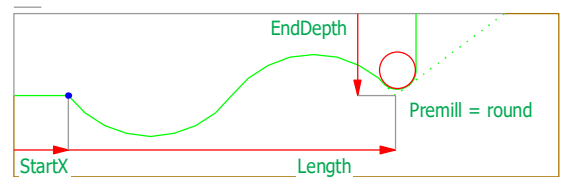
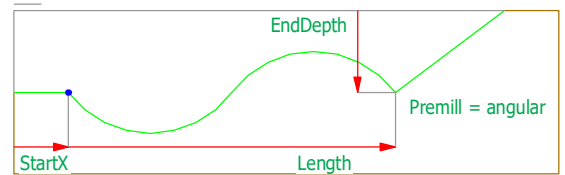
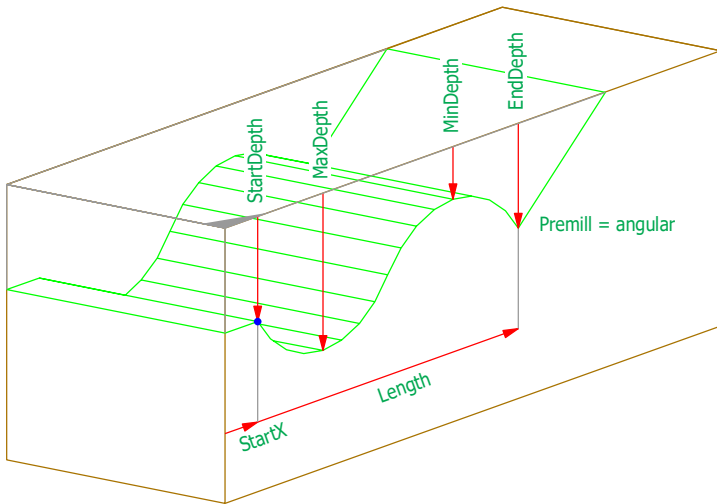

Orientation = end

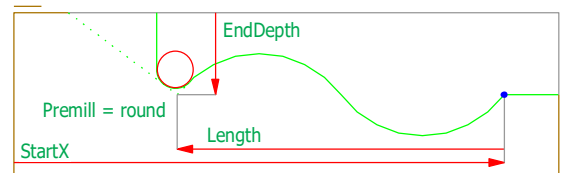
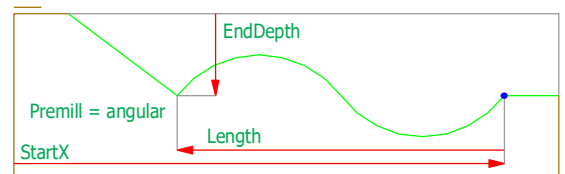
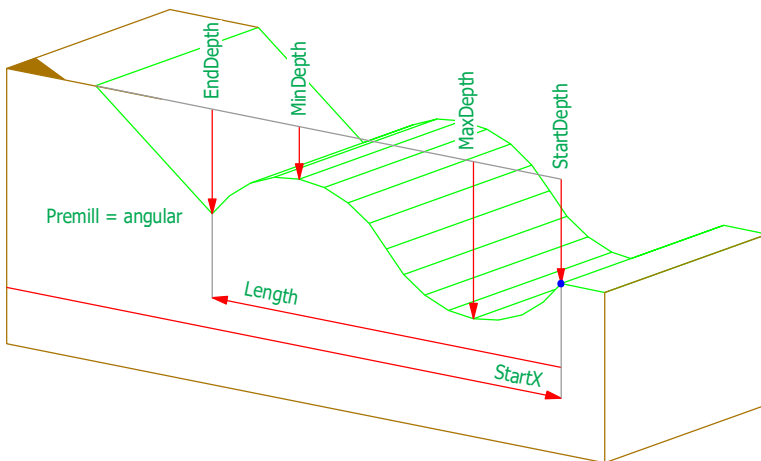

The curve is defined by a cubic polynomial.

$$Y = Ax^3 + Bx^2 + Cx + D$$

The coefficients A, B, C and D must be calculated on the machine side.

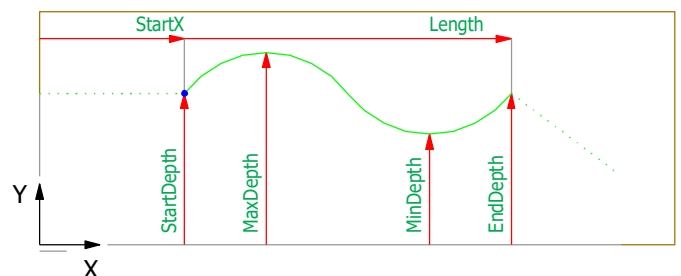

## Parameters ProfileCambered

Name	Type	Default	Min	Max
Orientation	OrientationType		start	end
StartX	LengthPosType	0.0	-100000.0	100000.0
Length	LengthType	0.0	0.0	100000.0
StartDepth	LengthSType	40.0	0.0	1000.0
MaxDepth	LengthSType	60.0	0.0	1000.0
MinDepth	LengthSType	10.0	0.0	1000.0
EndDepth	LengthSType	40.0	0.0	1000.0
Premill	PremillType	angular	round/angular	

### RoundArch

ArcShape = concave

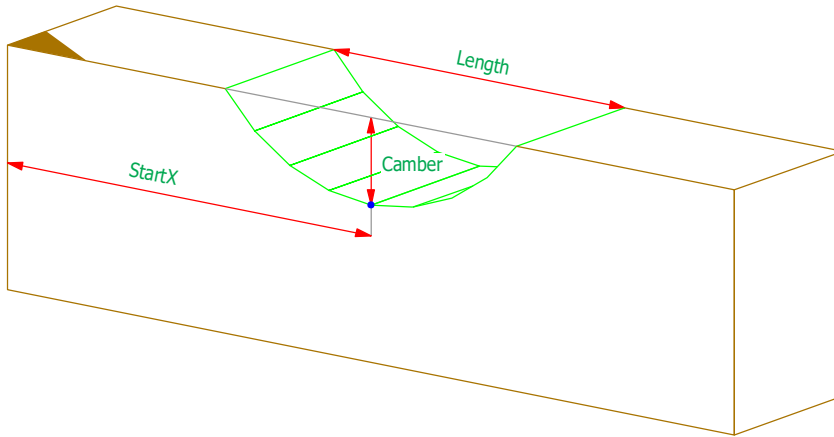

ArcShape = convex

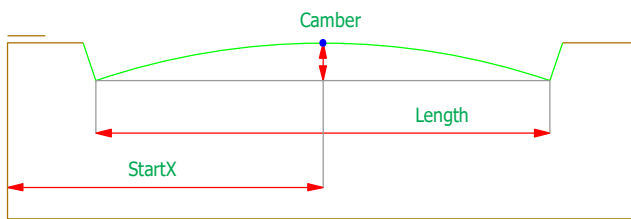

## Parameters RoundArch

Name	Type	Default	Min	Max
StartX	LengthPosType	0.0	-100000.0	100000.0
Length	LengthType	500.0	0.0	100000.0
Camber	LengthSType	30.0	0.0	1000.0
ArcShape	ArcShapeType	concave		
Premill	PremillType	angular	round/angular	



### ProfileHead

Orientation = start

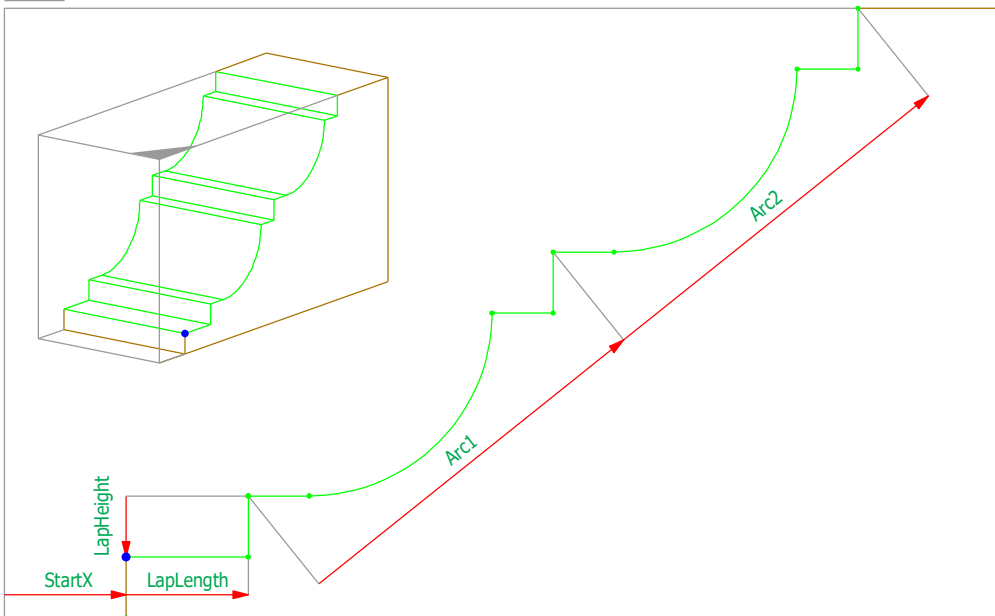

Orientation = end

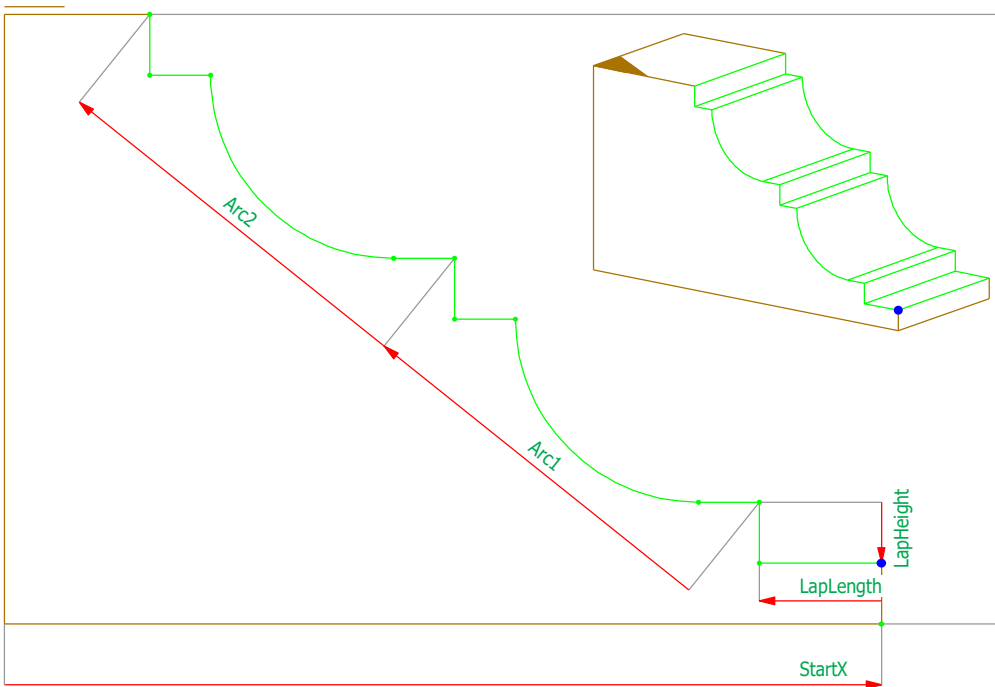

Parameters ProfileHead

Name	Type	Default	Min	Max
Orientation	OrientationType		start	end
StartX	LengthPosType	0.0	-100000.0	100000.0
Arc2	ProfileArcType			
LapLength	LengthSType	10.0	0.0	1000.0
LapHeight	LengthSType	10.0	0.0	1000.0

ProfileArcType

ArcShape	ArcShapeType	QuarterArc convex	QuarterArc/Segment convex/concave
LapLength	LengthSType	10.0	0.0 1000.0
LapHeight	LengthSType	10.0	0.0 1000.0
Displacement	LengthSType	10.0	0.0 1000.0

QuarterArc

Radius	LengthSType	50.0	0.0 1000.0
--------	-------------	------	------------

Segment

Length	LengthSType	50.0	0.0 1000.0
Height	LengthSType	50.0	0.0 1000.0
Camber	LengthSType	50.0	0.0 1000.0

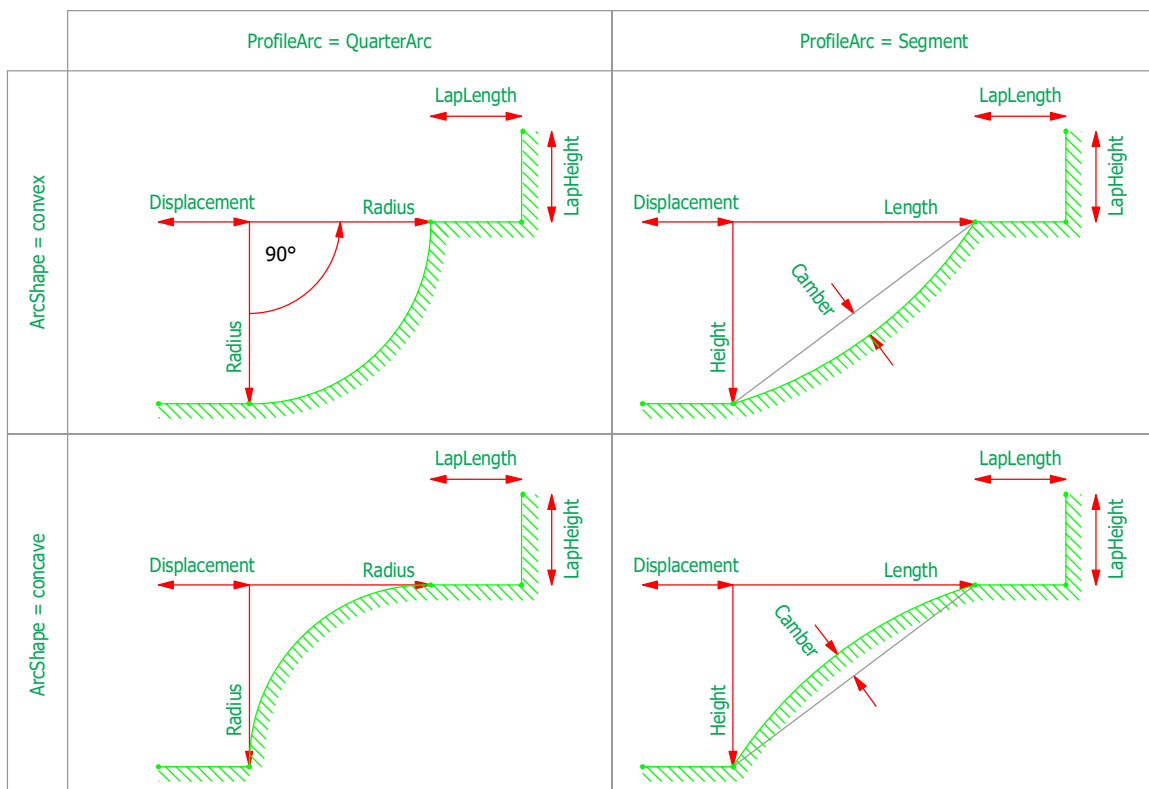

### Sphere

Orientation = start

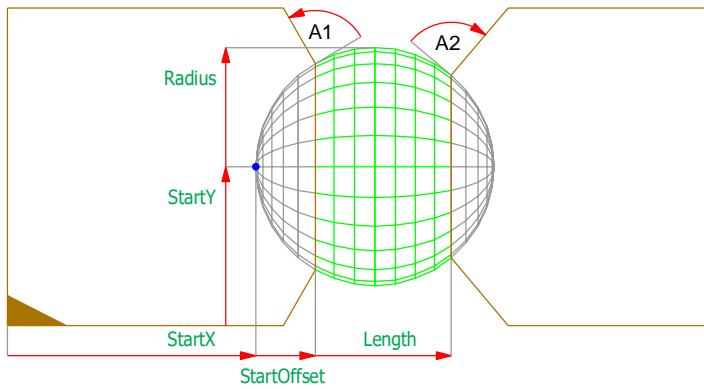

A1 and A2 are defined on the machine side. They depend on the capabilities of the machine. In this pictures A1 and A2 are 90° .

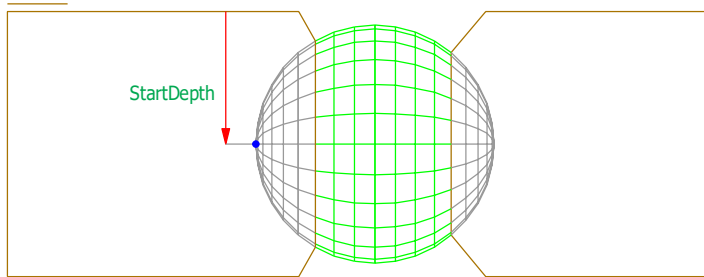

Orientation = end

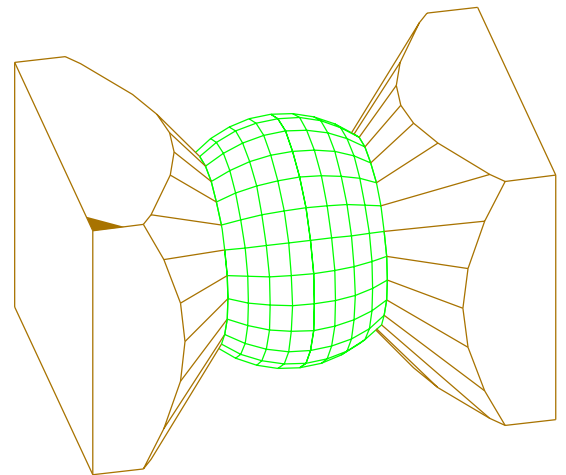
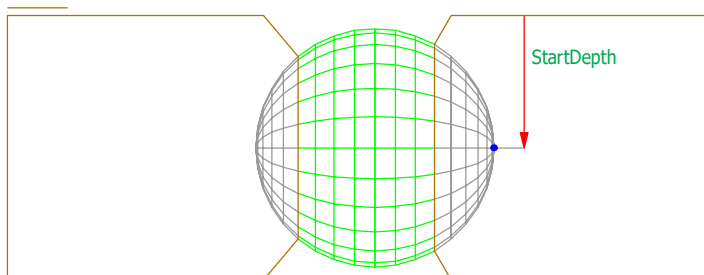
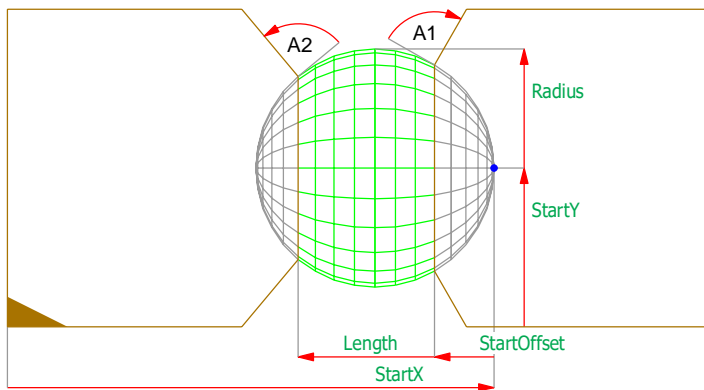

## Parameters Sphere

Name	Type	Default	Min	Max
Orientation	OrientationType		start	end
StartX	LengthPosType	0.0	-100000.0	100000.0
StartY	WidthNType	60.0	-50000.0	50000.0
StartDepth	WidthNType	60.0	-50000.0	50000.0
Length	WidthType	50.0	0.0	50000.0
Radius	WidthType	50.0	0.0	50000.0
StartOffset	WidthType	0.0	0.0	50000.0

### TriangleCut

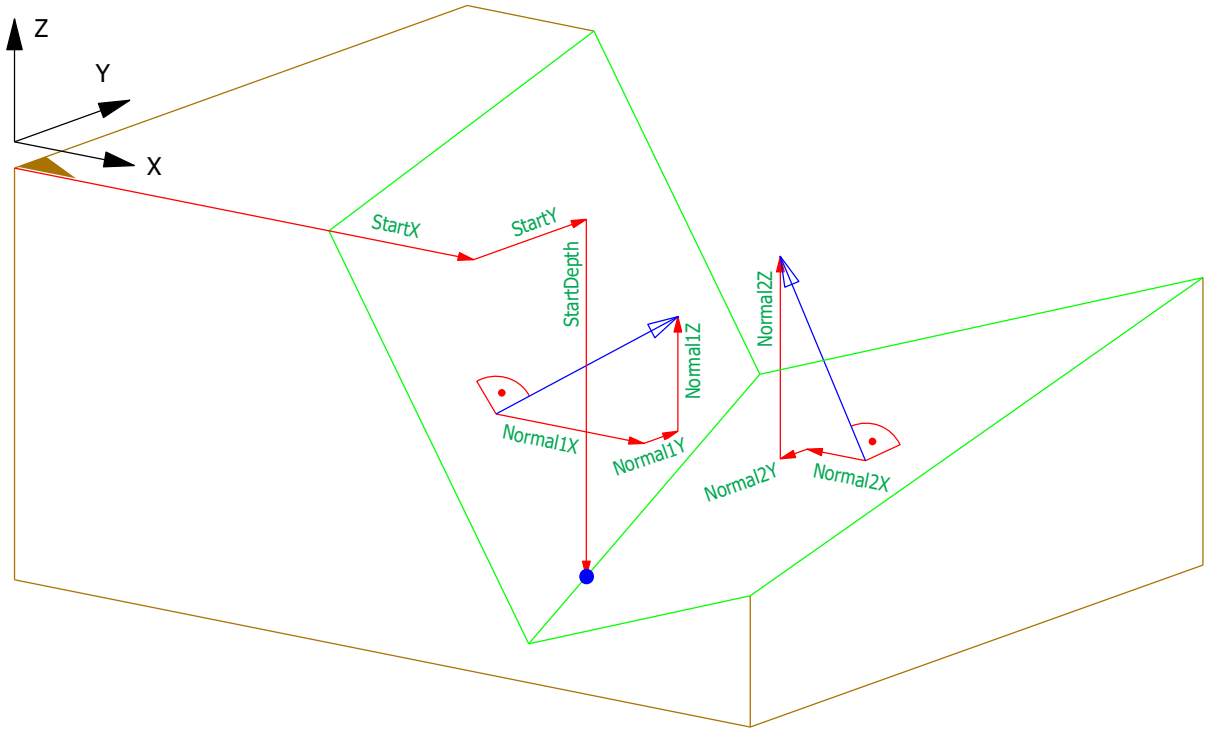

## Parameters TriangleCut

Name	Type	Default	Min	Max
StartX	LengthPosType	0.0	-100000.0	100000.0
StartY	WidthNType	60.0	-50000.0	50000.0
StartDepth	WidthNType	60.0	-50000.0	50000.0
Normal1X	WidthNType	1.0	-50000.0	50000.0
Normal1Y	WidthNType	0.0	-50000.0	50000.0
Normal1Z	WidthNType	0.0	-50000.0	50000.0
Normal2X	WidthNType	1.0	-50000.0	50000.0
Normal2Y	WidthNType	0.0	-50000.0	50000.0
Normal2Z	WidthNType	0.0	-50000.0	50000.0

### TyroleanDovetail

Orientation = start

LapPosition = refedge

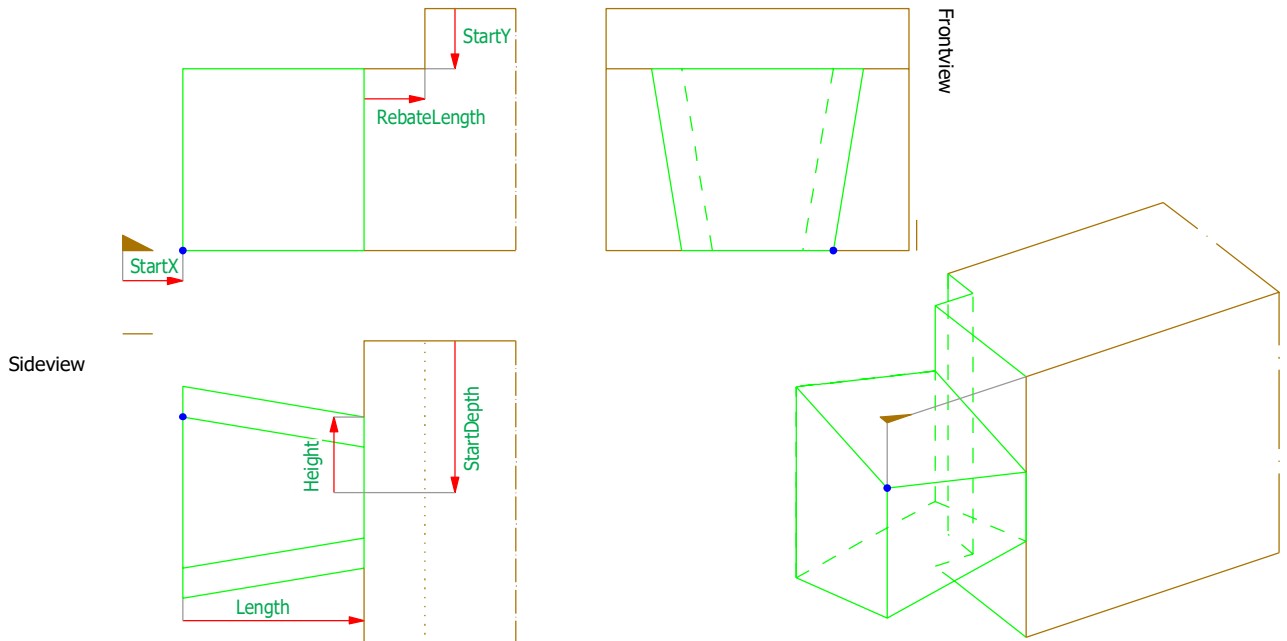

LapPosition = oppedge

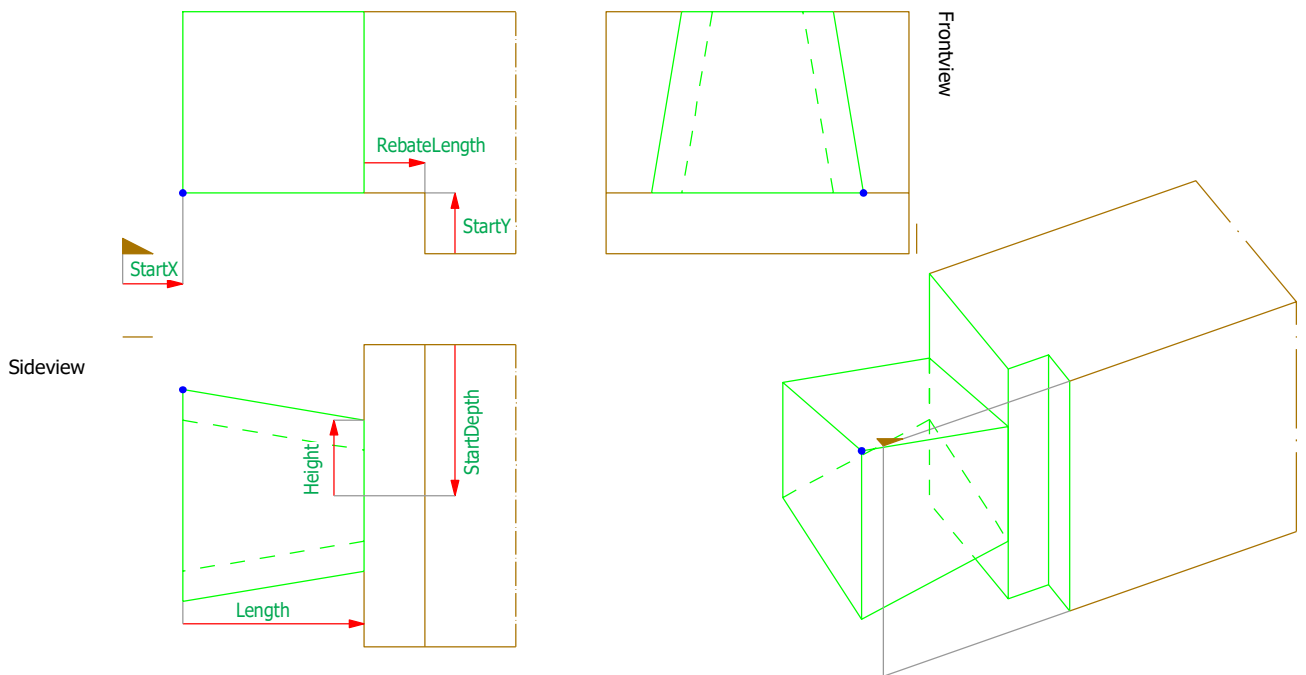

CutOff = yes

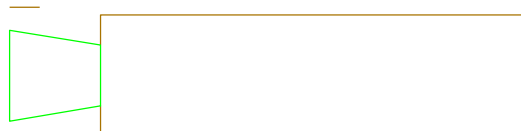

CutOff = no

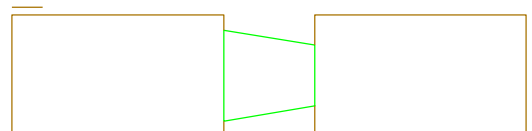

TyroleanDovetail

Orientation = start

LapPosition = refedge

LapPosition = oppedge

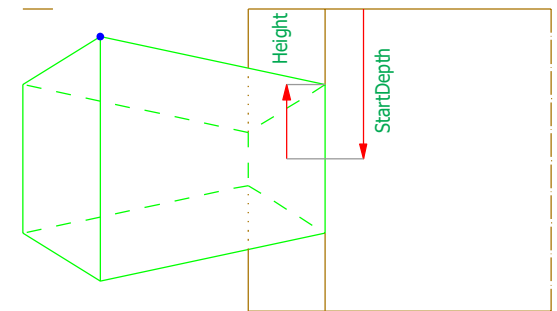
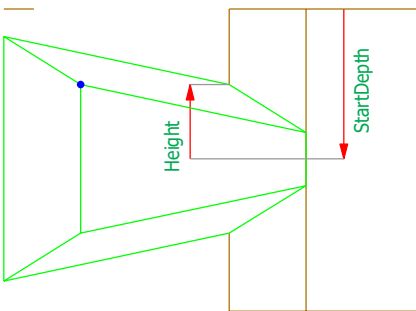
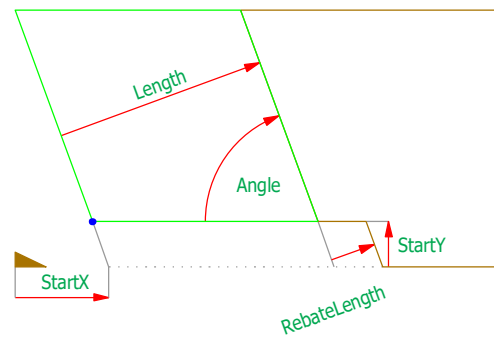
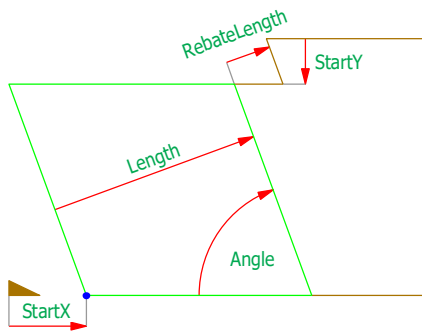
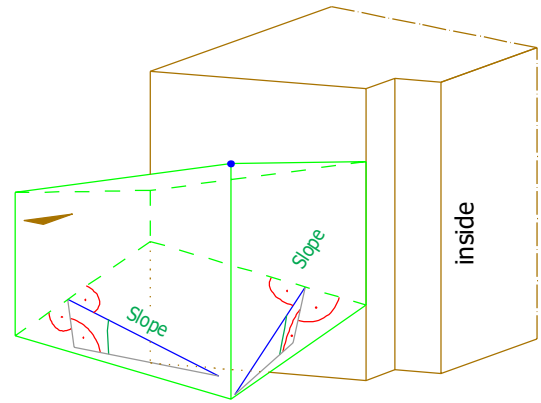
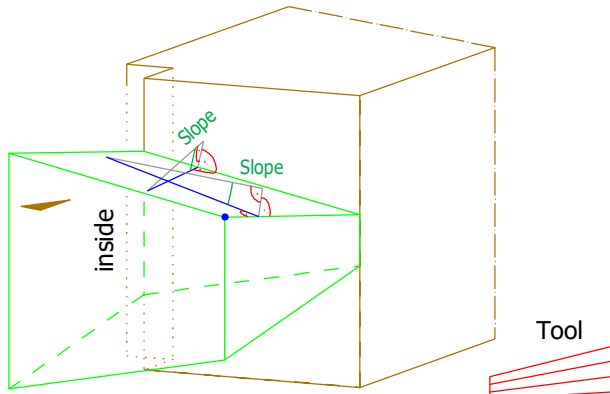

LapExit = none

LapExit = mitre

LapExit = rebate

LapExit = none

LapExit = mitre

LapExit = rebate

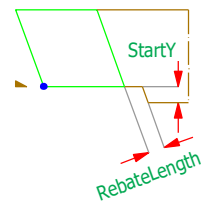
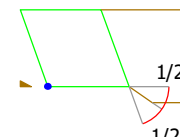
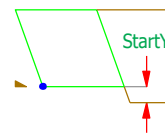
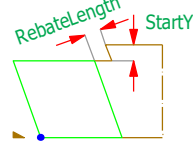
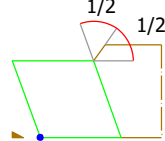
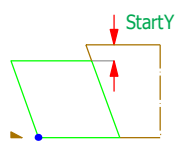



### TyroleanDovetail

Orientation = start

LapPosition = refedge

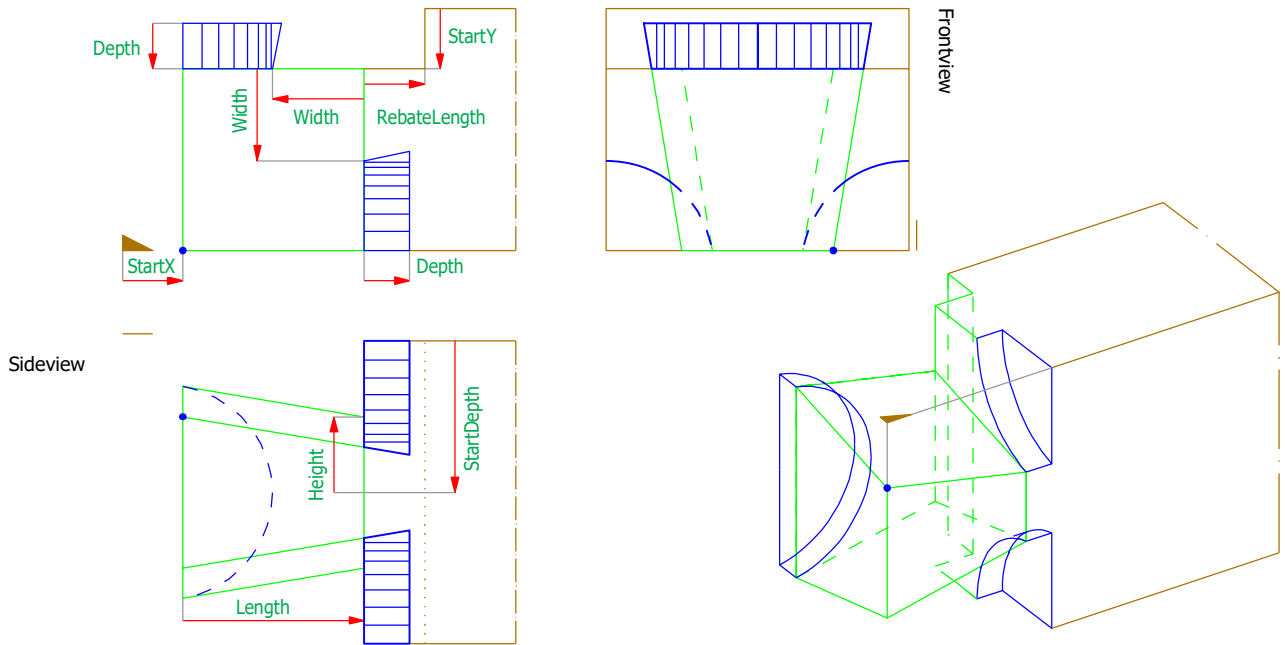

LapPosition = oppedge

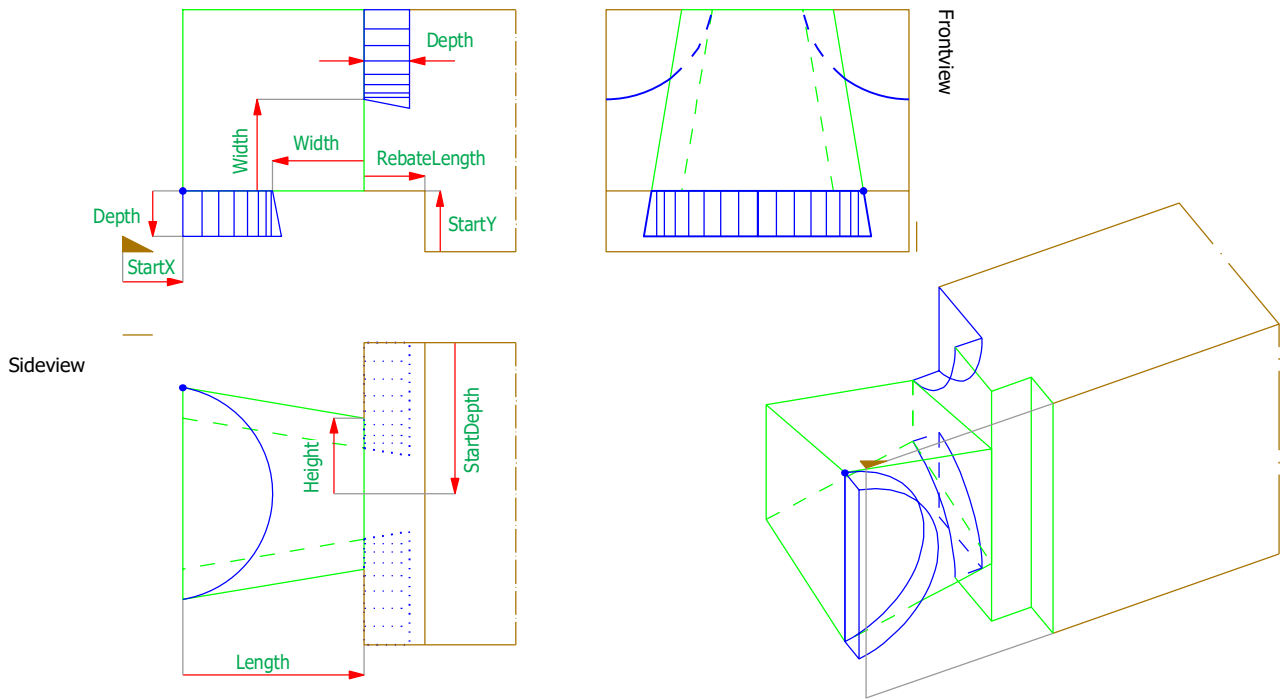

### TyroleanDovetail

Orientation = start

LapPosition = refedge

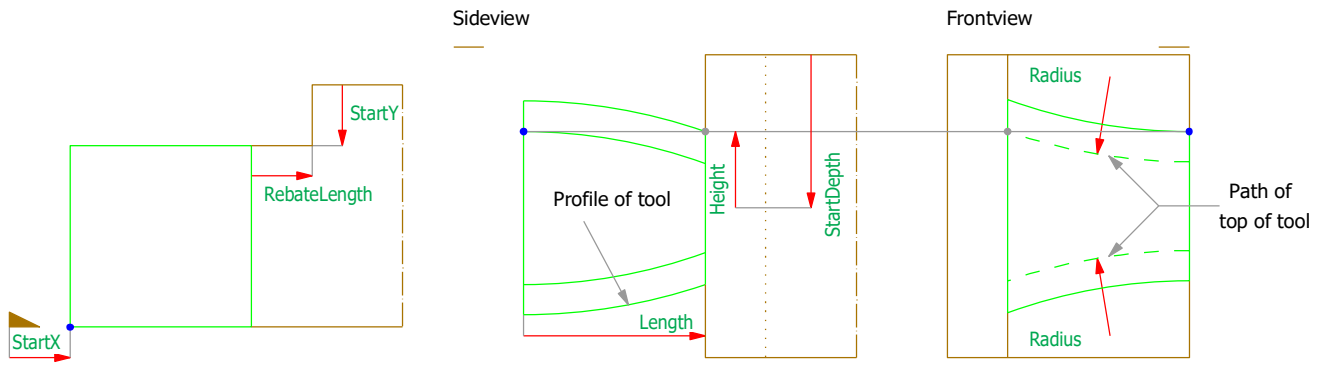

LapPosition = oppedge

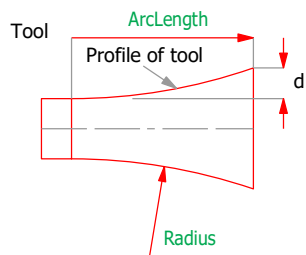
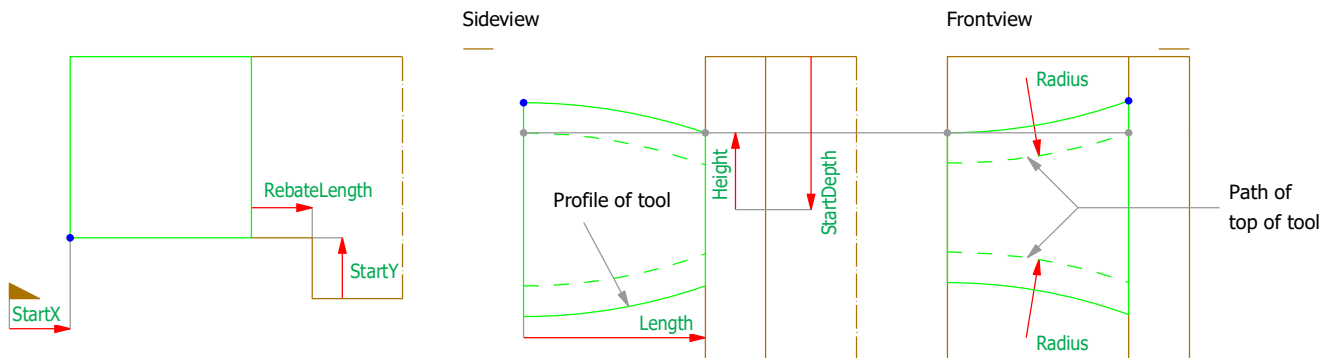

### TyroleanDovetail

Orientation = end

CutOff = yes

LapPosition = refedge

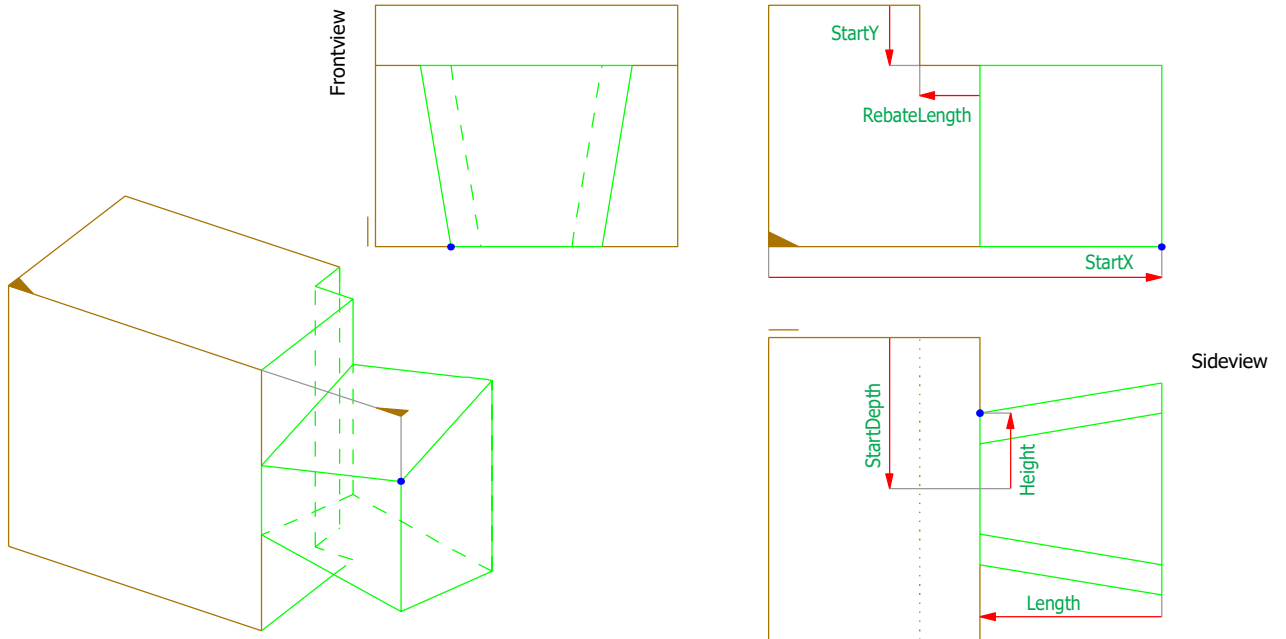

LapPosition = oppedge

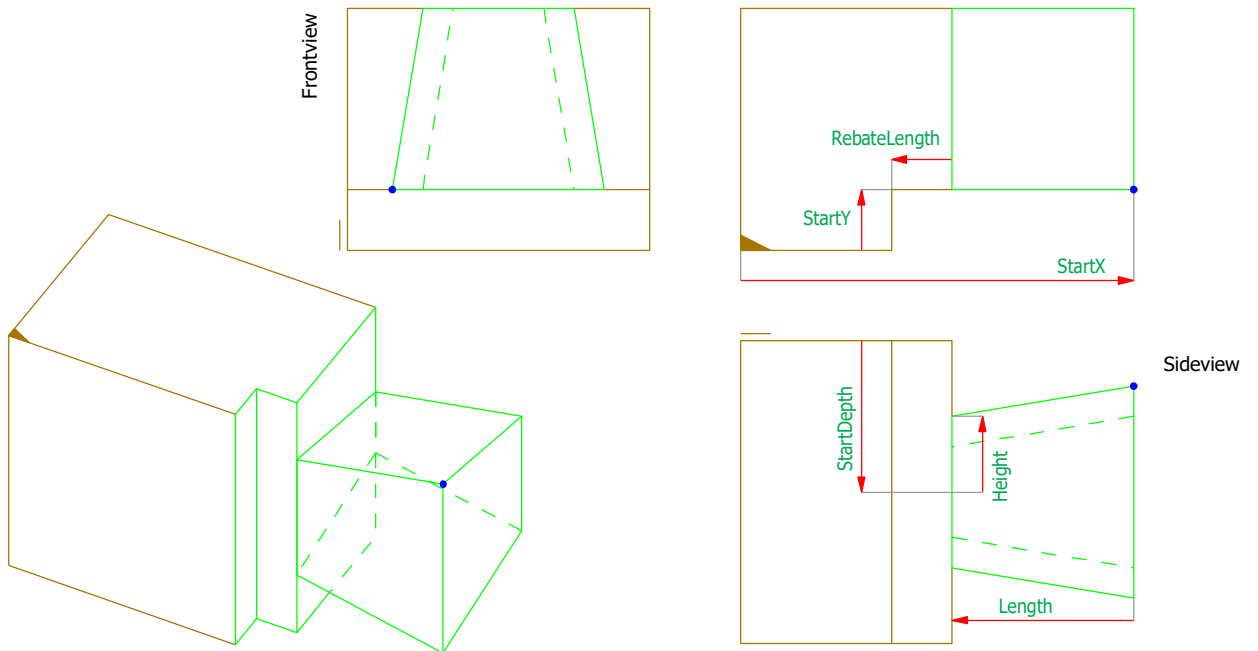

CutOff = yes

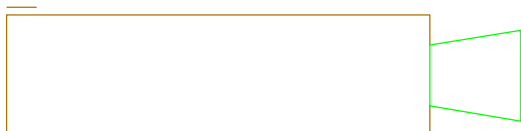

CutOff = no

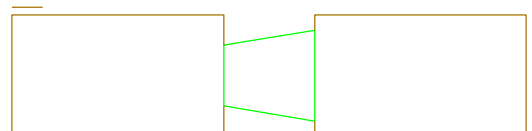

TyroleanDovetail

Orientation = end

LapPosition = refedge

LapPosition = oppedge

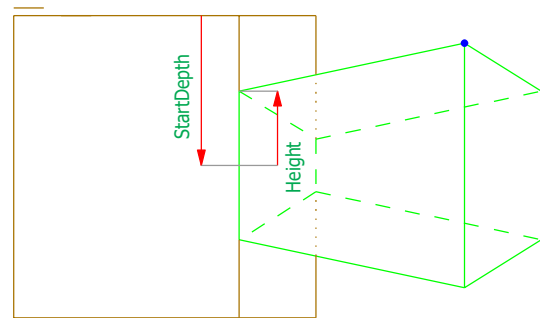
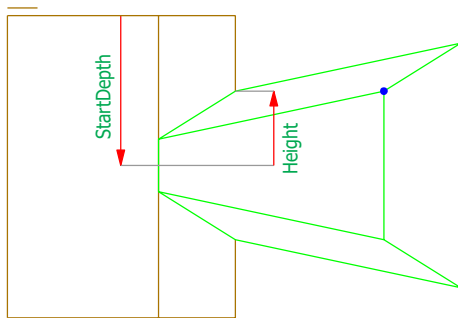
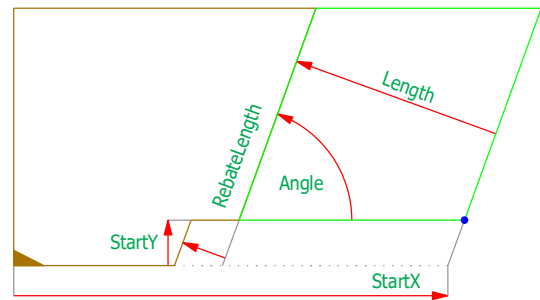
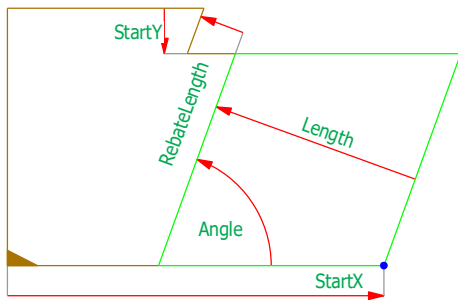
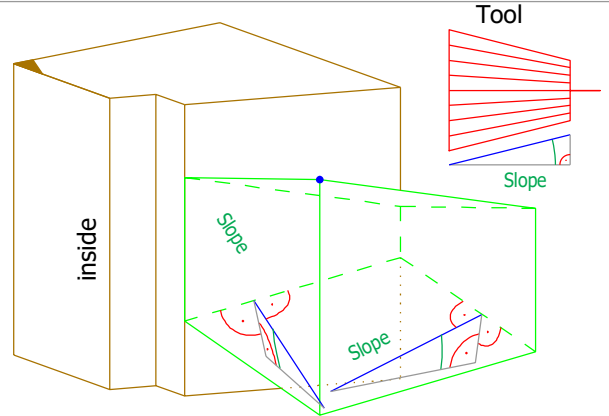
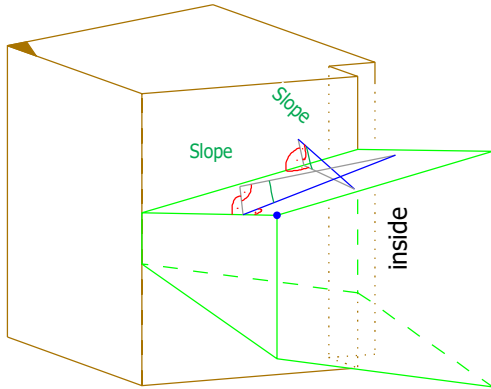

LapExit = none

LapExit = mitre

LapExit = rebate

LapExit = none

LapExit = mitre

LapExit = rebate

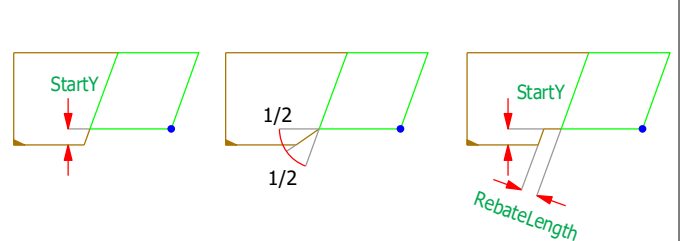
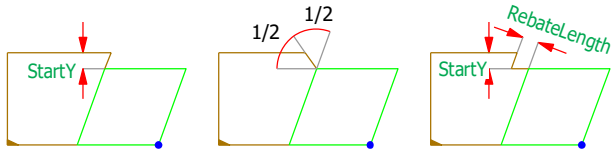

### TyroleanDovetail

Orientation = end

LapPosition = refedge

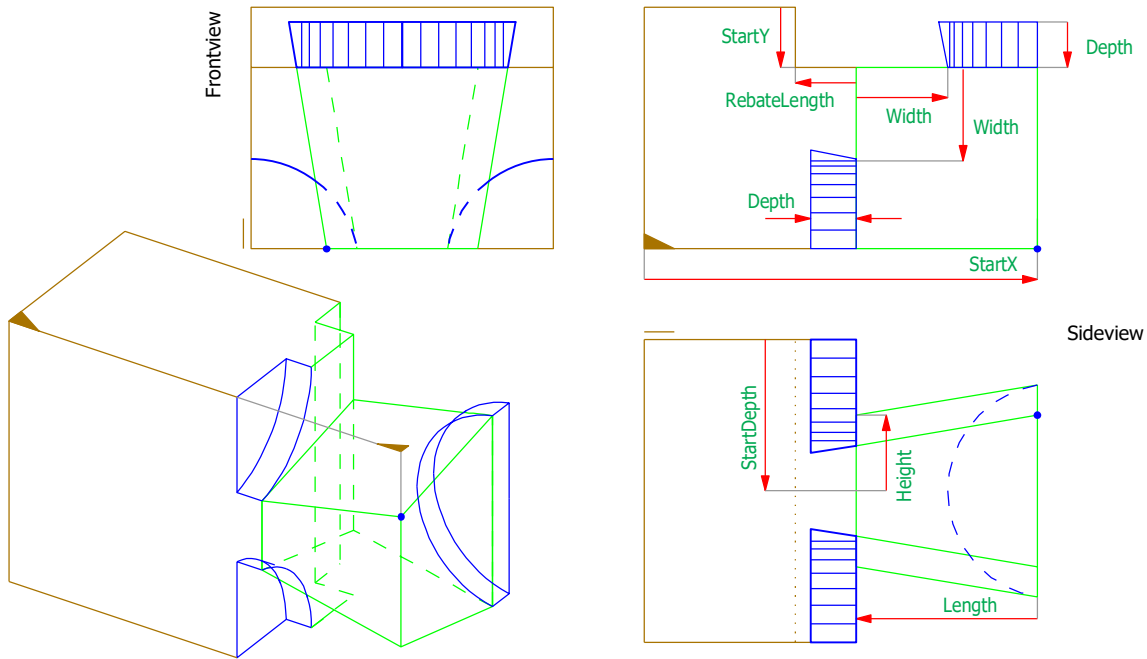

LapPosition = oppedge

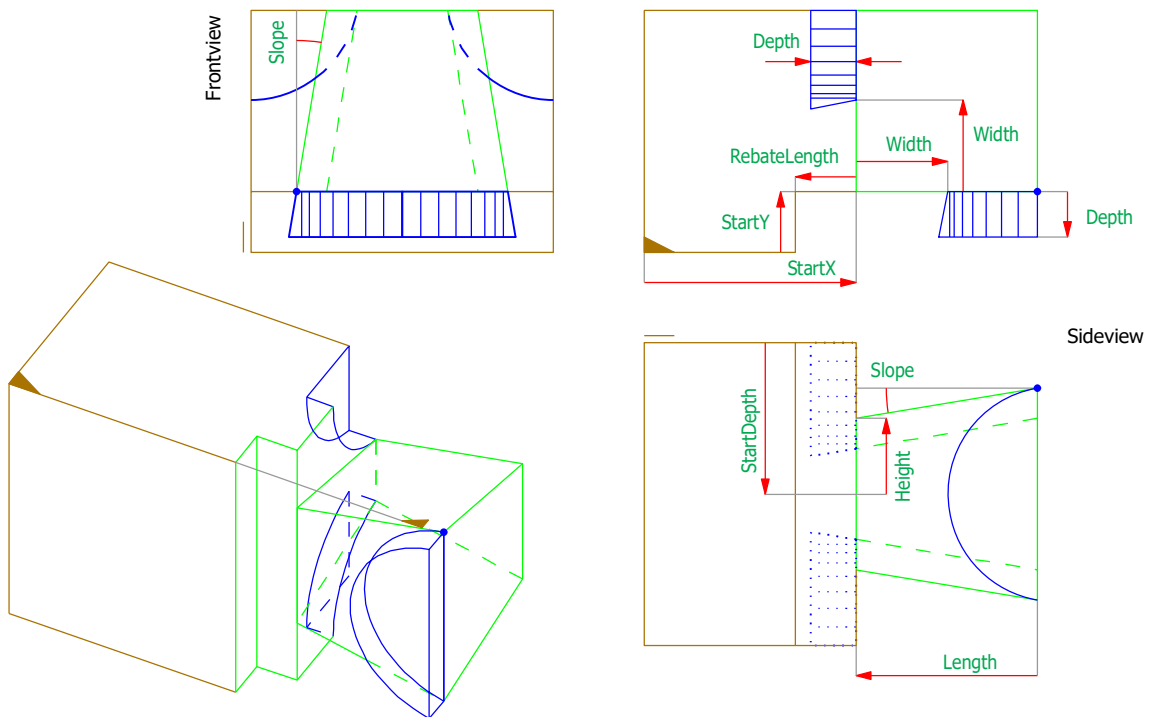

TyroleanDovetail

Orientation = end

LapPosition = refedge

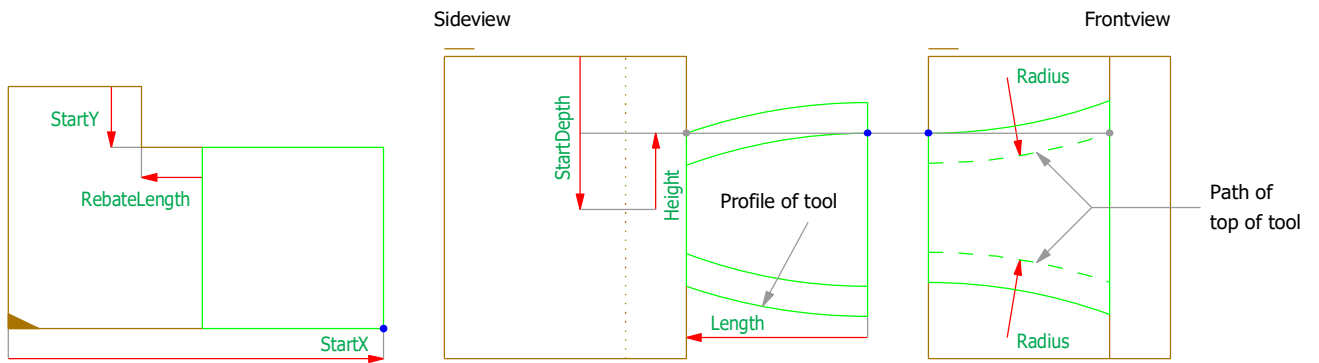

LapPosition = oppedge

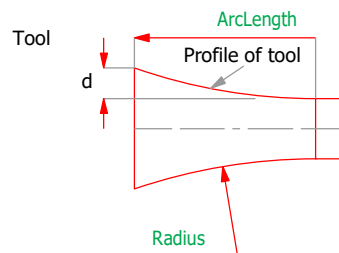
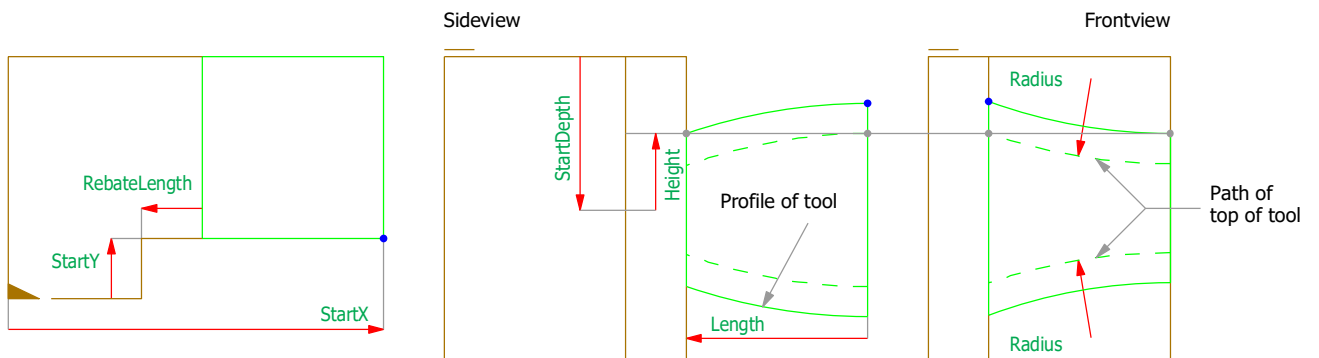

## Tyrolean Dovetail

Name	Type	Default	Min	Max
Orientation	OrientationType		start	end
CutOff	BooleanType	no	no	yes
StartX	LengthPosType	0.0	-100000.0	100000.0
StartY	WidthType	30.0	0.0	50000.0
StartDepth	WidthNType	50.0	-50000.0	50000.0
Angle	AngleType		0.1	179.9
Slope	double		0.0	45.0
Length	WidthType	150.0	0.0	50000.0
RebateLength	WidthType	10.0	0.0	50000.0
Height	WidthType	60	0.0	50000.0
LapPosition	EdgePositionType	refedge	refedge/oppedge	
LapExit	LapExitType	mitre	none/mitre/rebate	
Shape	TyroleanDovetailShapeType	angular	angular/straight	
ProcessSide	ProcessSideType	both	both/refside/oppside	

## Frosch

Name	Type	Default	Min	Max
Width	WidthType			
Depth	WidthType			

## Klingschrot

Name	Type	Default	Min	Max
Radius	WidthType			
ArcLength	WidthType			

Dovetail

Orientation = start

	LapPosition = refedge	LapPosition = oppedge
Shape = european		
Shape = american		
LapExit	<p>LapExit = none</p> <p>LapExit = mitre</p> <p>LapExit = rebate</p>	<p>LapExit = none</p> <p>LapExit = mitre</p> <p>LapExit = rebate</p>



Dovetail

Orientation = end

	LapPosition = refedge	LapPosition = oppedge
Shape = european		
Shape = american		
LapExit	<p>LapExit = none</p> <p>LapExit = mitre</p> <p>LapExit = rebate</p>	<p>LapExit = none</p> <p>LapExit = mitre</p> <p>LapExit = rebate</p>

## Dovetail

Name	Type	Default	Min	Max
Orientation	OrientationType		start	end
CutOff	BooleanType	no	no	yes
StartX	LengthPosType	0.0	-100000.0	100000.0
StartY	WidthType	30.0	0.0	50000.0
StartDepth	WidthNType	50.0	-50000.0	50000.0
Slope	double		0.0	45.0
Length	WidthType	150.0	0.0	50000.0
RebateLength	WidthType	10.0	0.0	50000.0
HeightRefSide	WidthType	60	0.0	50000.0
HeightOppSide	WidthType	30.0	0.0	50000.0
LapPosition	EdgePositionType	refedge	refedge/oppedge	
LapExit	LapExitType	mitre	none/mitre/rebate	
Shape	DovetailShapeType	european	european/american	
ProcessSide	ProcessSideType	both	both/refside/oppside	

ProcessSide = both

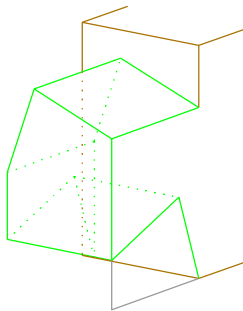

ProcessSide = refside

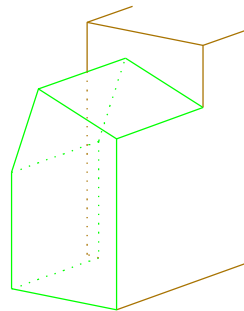

ProcessSide = oppside

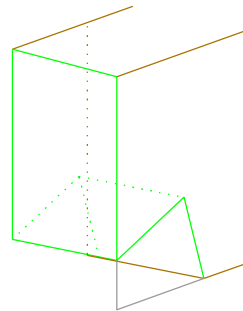

### SimpleContour

The elements of a SimpleContour are a Startpoint and a list of Lines and Arcs.

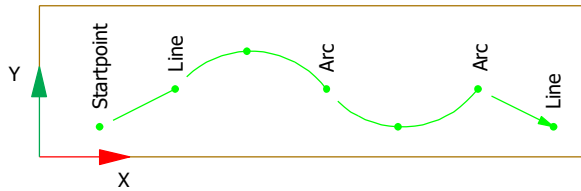
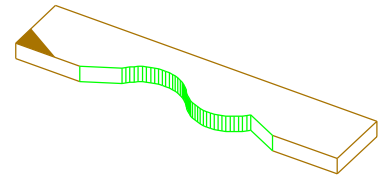
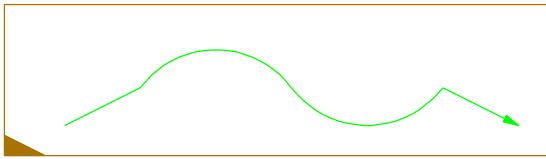

Name	Type
StartPoint	PointType
Line	LineType
Arc	Arctype

### ToolPosition

Toolposition = left

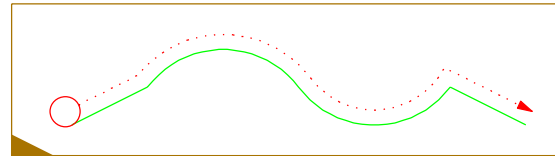

Toolposition = center

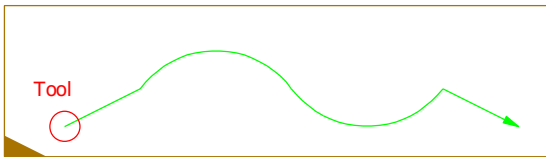

Toolposition = right

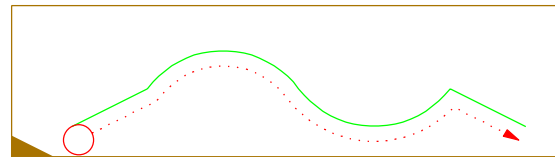

### Depth

DepthBounded = yes

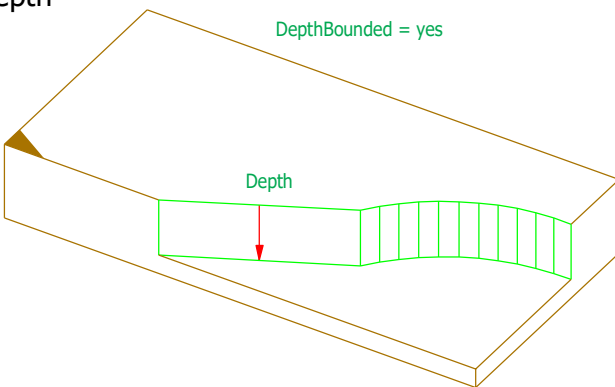

DepthBounded = no

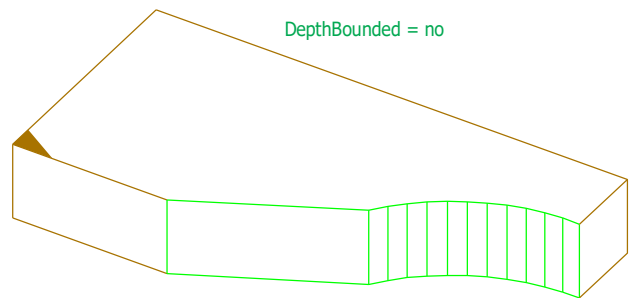

### Circle

The circle must be defined with 2 arcs a 180 degrees.

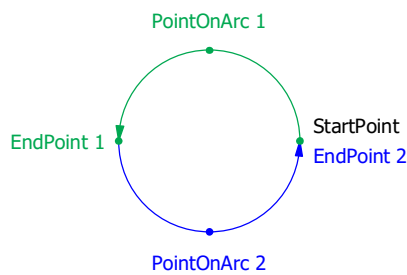

### Inclination

In this view the contour is oriented away from the observer.

Toolposition = left or center

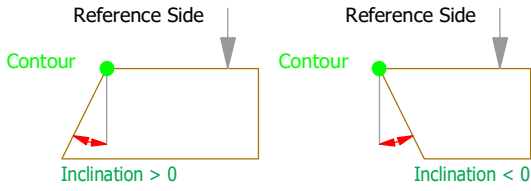

Toolposition = right

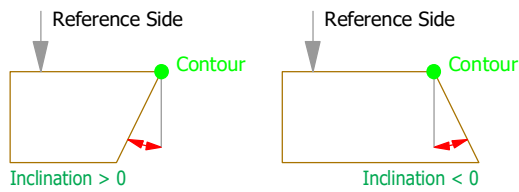

The inclination is constant over the length of the segment and is always measured from the tangent of the contour at the actual point.

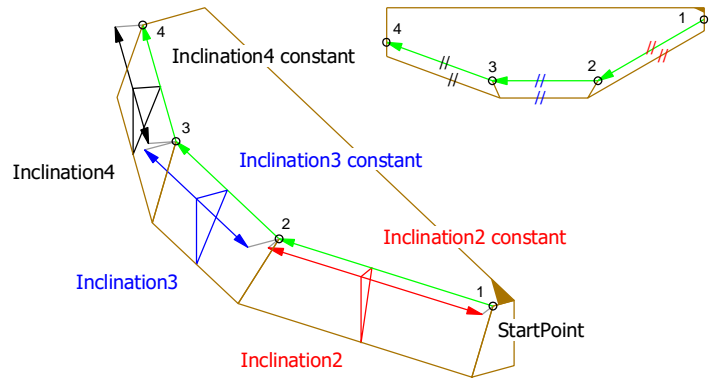

### DualContour

Name	Type
PrincipalContour	SimpleContourType
AssociatedContour	SimpleContourType

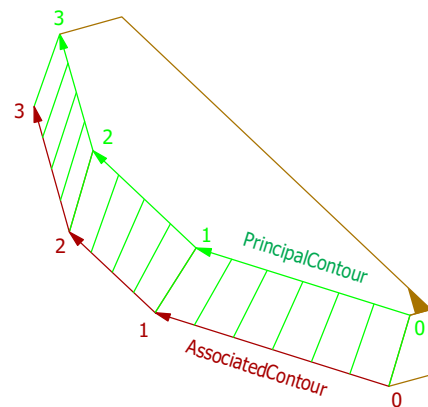

### ContourRecess

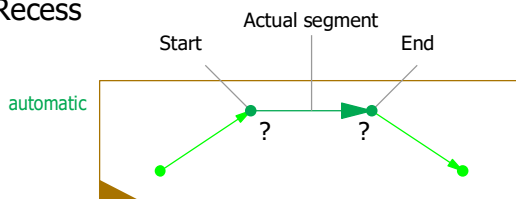

The processing at the vertices has to be specified by the machine

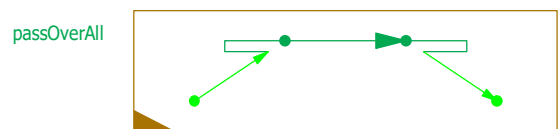
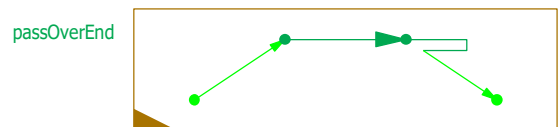
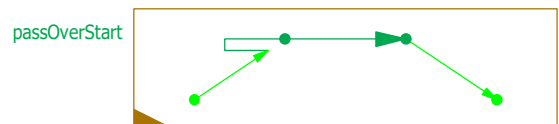
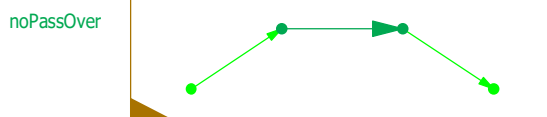

The machineside decides, how the RECESS is worked out. Examples:



### Aperture

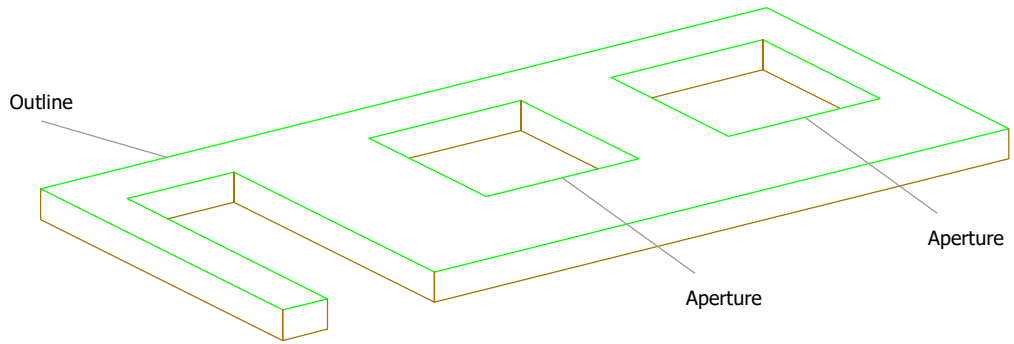

### CounterSink

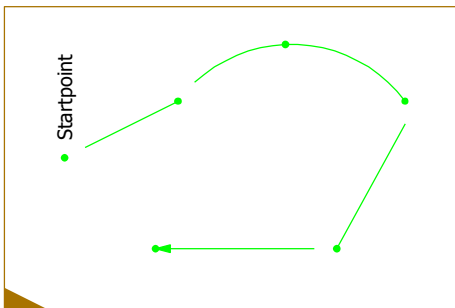

CounterSink = no

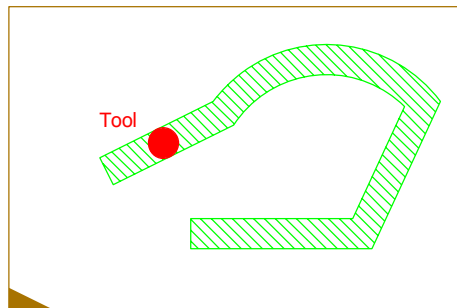

CounterSink = yes

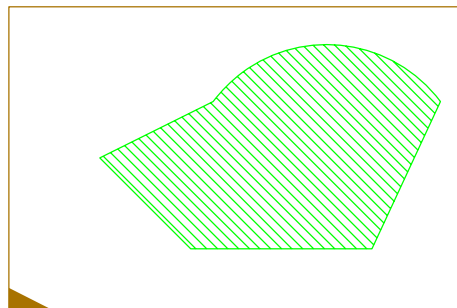

Listing in the BTLX-File

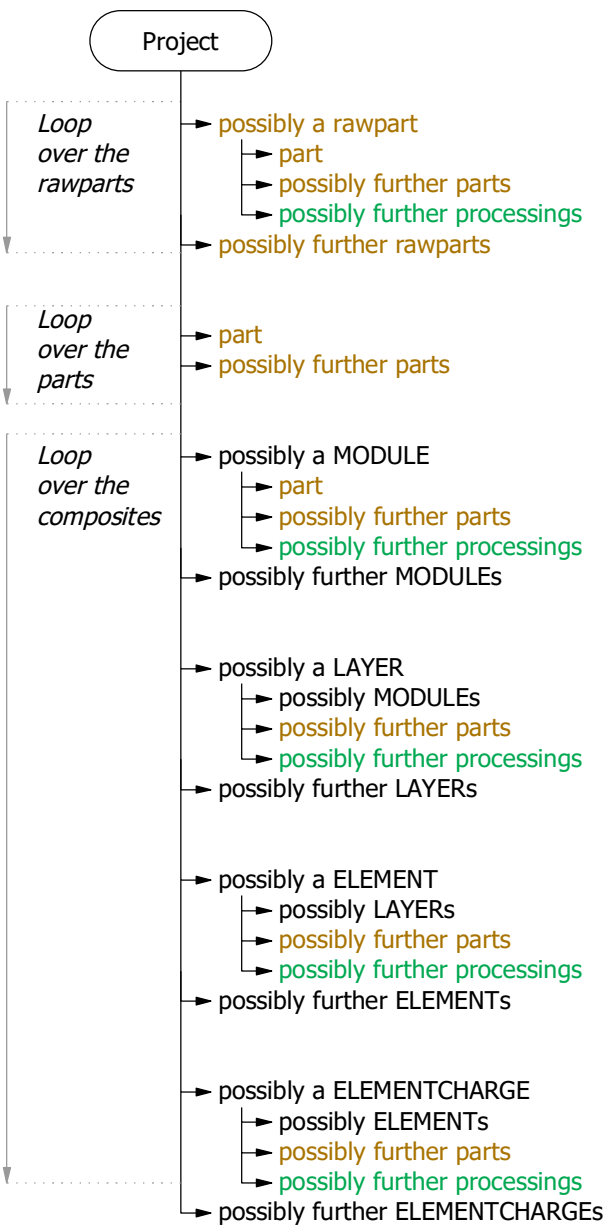

Hierarchical ordering

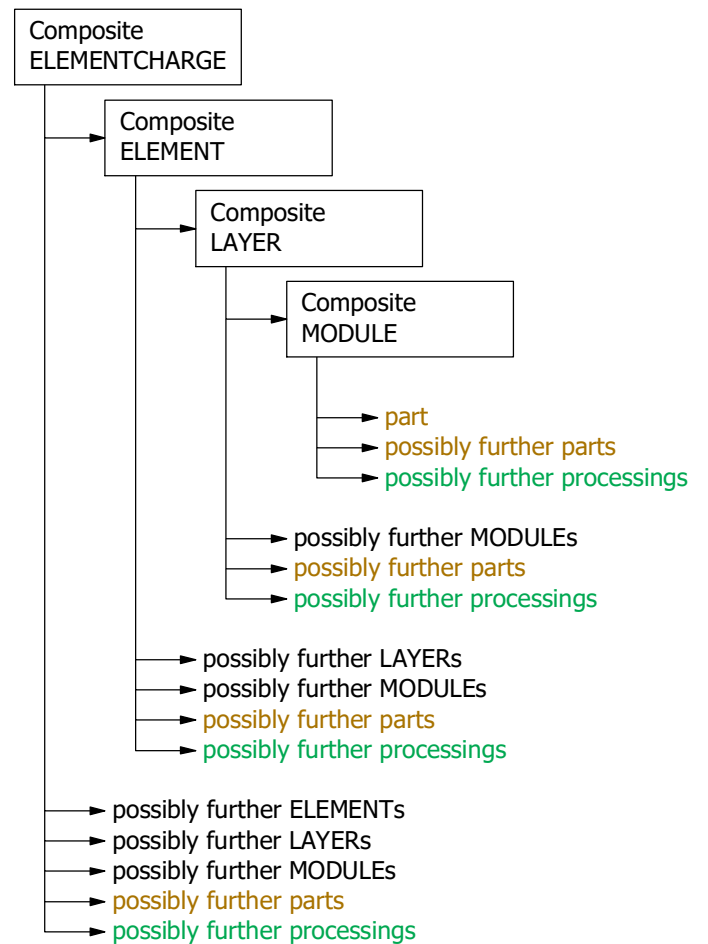

Example for a composite

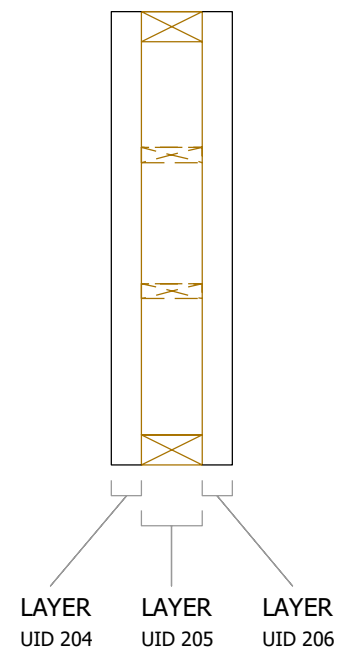
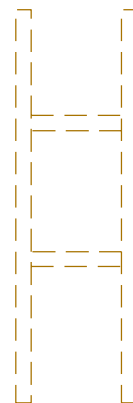
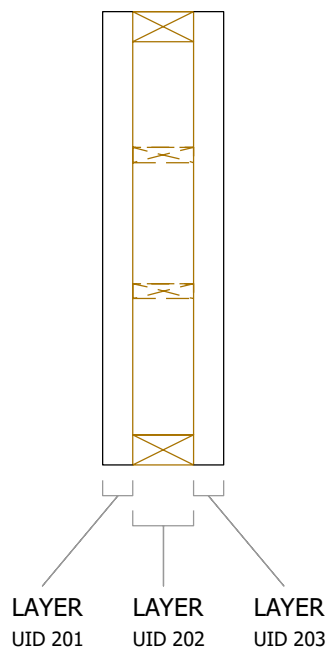
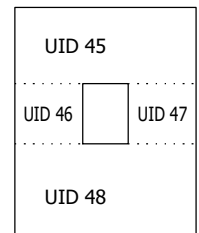
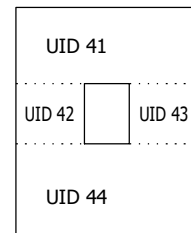
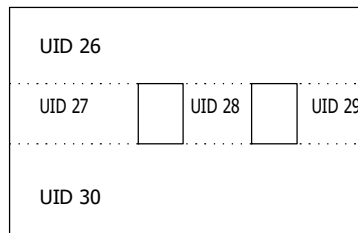
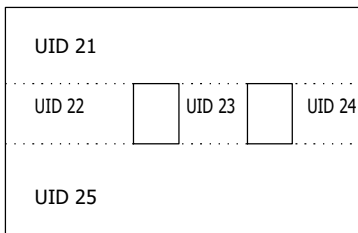
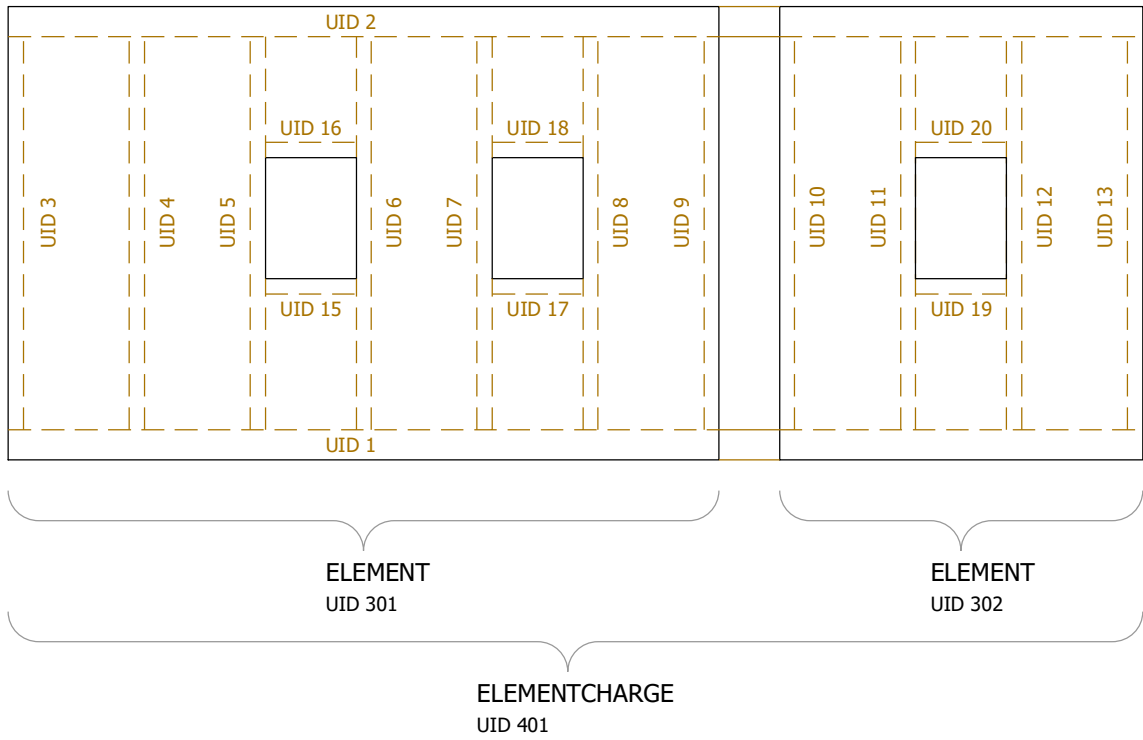

[PART]  
 UID: 1,2  
 processings ...  
 [PART]  
 UID: 3,4,5,6,7,8,9  
 UID: 10,11,12,13  
 processings ...  
 [PART]  
 UID: 15,16,17,18  
 processings ...

[PART]  
 UID: 21,26  
 processings ...  
 [PART]  
 UID: 22,27  
 processings ...  
 [PART]  
 UID: 23,28  
 processings ...  
 [PART]  
 UID: 24,29  
 processings ...  
 [PART]  
 UID: 25,30  
 processings ...

[PART]  
 UID: 41,45  
 processings ...  
 [PART]  
 UID: 42,46  
 processings ...  
 [PART]  
 UID: 43,47  
 processings ...  
 [PART]  
 UID: 44,48  
 processings ...

[COMPOSITE]  
 TYPE: MODULE  
 UID: 101  
 contains UID 5,6,15,16  
 processings ...  
 [COMPOSITE]  
 TYPE: MODULE  
 UID: 102  
 contains UID 7,8,17,18  
 processings ...  
 [COMPOSITE]  
 TYPE: MODULE  
 UID: 103  
 contains UID 11,12,19,20  
 processings ...

[COMPOSITE]  
 TYPE: LAYER  
 UID: 201  
 contains UID 21,22,23,24,25  
 processings ...  
 [COMPOSITE]  
 TYPE: LAYER  
 UID: 202  
 contains UID 101,102  
 contains UID 3,4,9  
 processings ...  
 [COMPOSITE]  
 TYPE: LAYER  
 UID: 203  
 contains UID 26,27,28,29,30  
 processings ...

[COMPOSITE]  
 TYPE: LAYER  
 UID: 204  
 contains UID 41,42,43,44  
 processings ...  
 [COMPOSITE]  
 TYPE: LAYER  
 UID: 205  
 contains UID 103  
 contains UID 10,13  
 processings ...  
 [COMPOSITE]  
 TYPE: LAYER  
 UID: 206  
 contains UID 45,46,47,48  
 processings ...

[COMPOSITE]  
 TYPE: ELEMENT  
 UID: 301  
 contains UID 201,202,203  
 processings ...  
 [COMPOSITE]  
 TYPE: ELEMENT  
 UID: 302  
 contains UID 204,205,206  
 processings ...

[COMPOSITE]  
 TYPE: ELEMENTCHARGE  
 UID: 401  
 contains UID 301,302  
 contains UID 1,2  
 processings ...

End of example for a composite