

TyroleanDovetail

Orientation = start

LapPosition = refedge

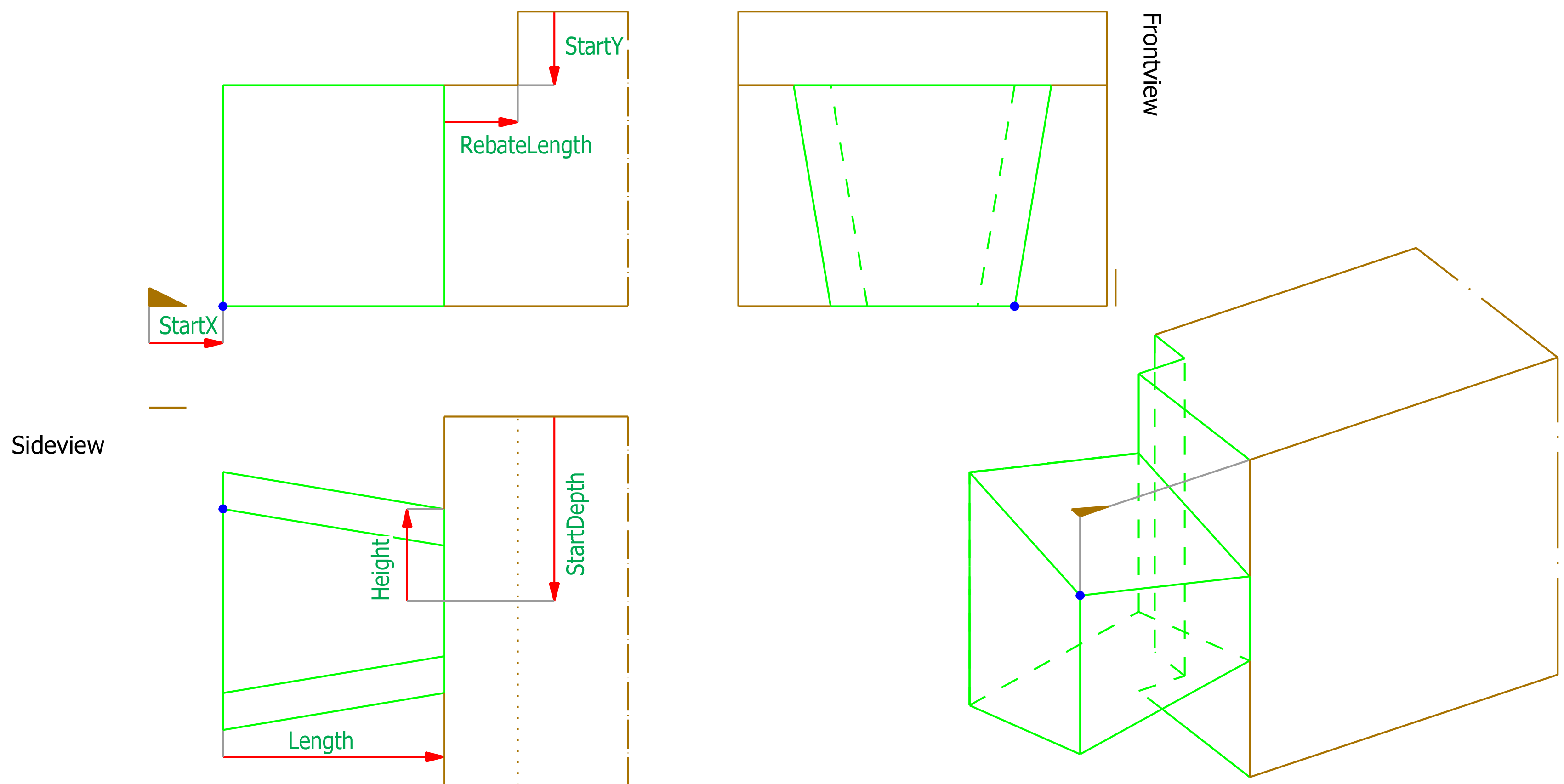

LapPosition = oppedge

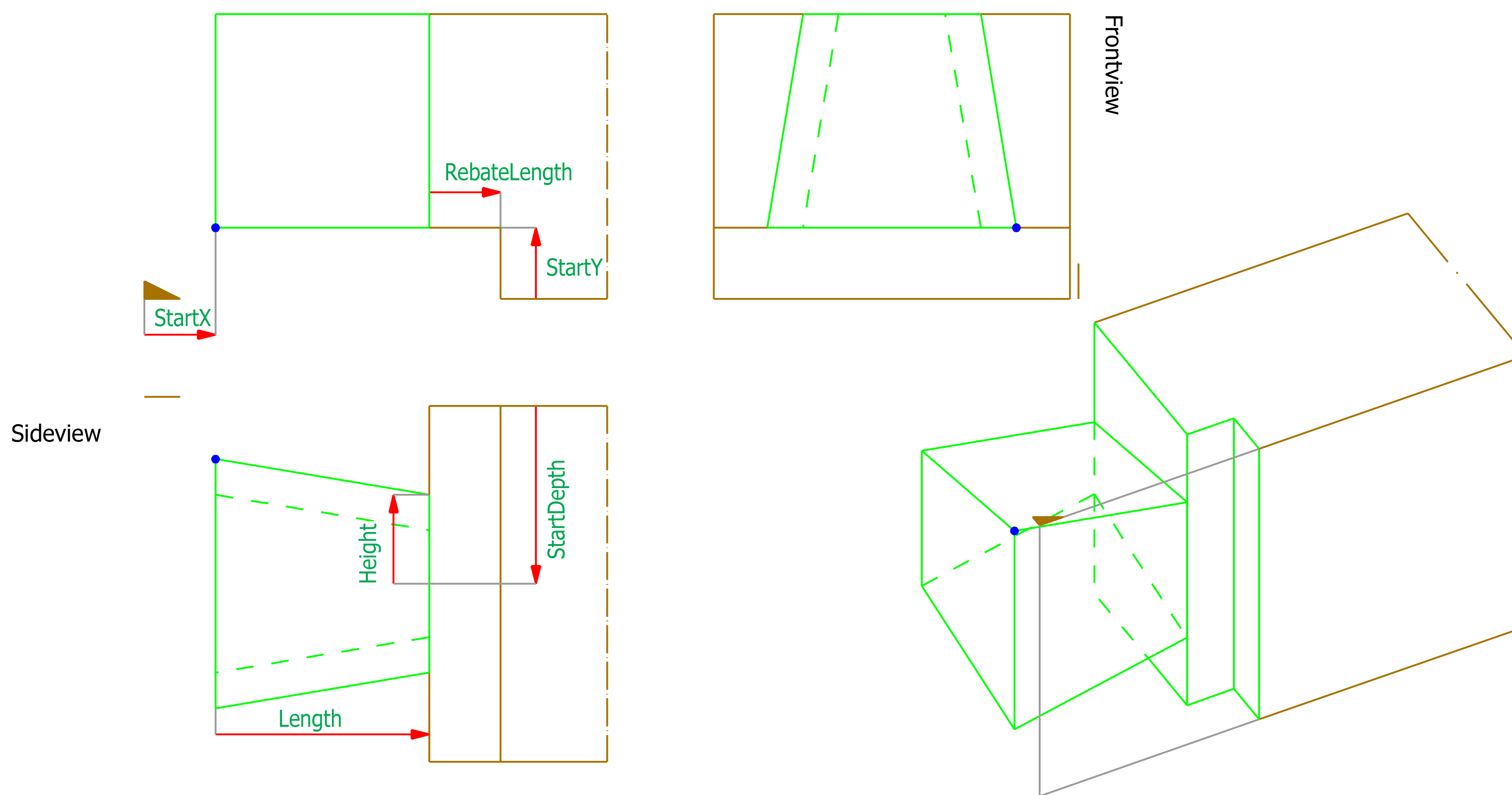

CutOff = yes

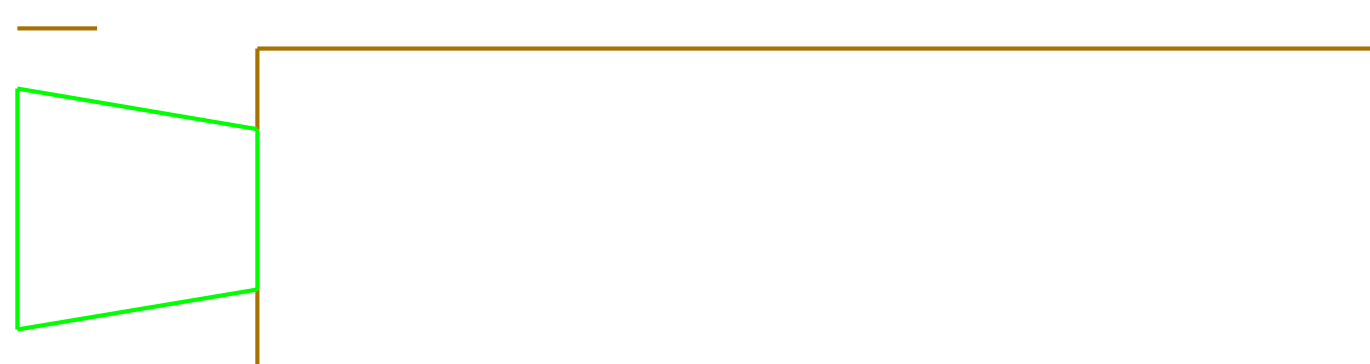

CutOff = no

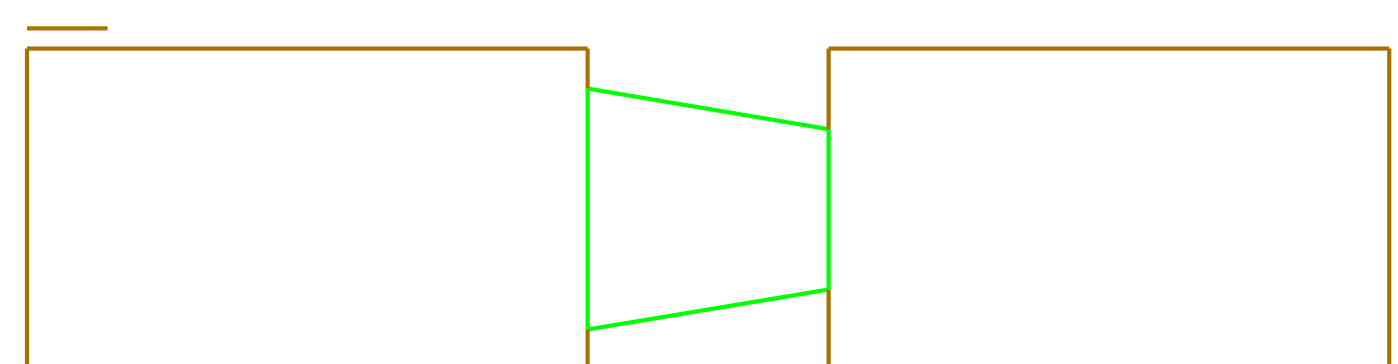

TyroleanDovetail

Orientation = start

LapPosition = refedge

LapPosition = oppedge

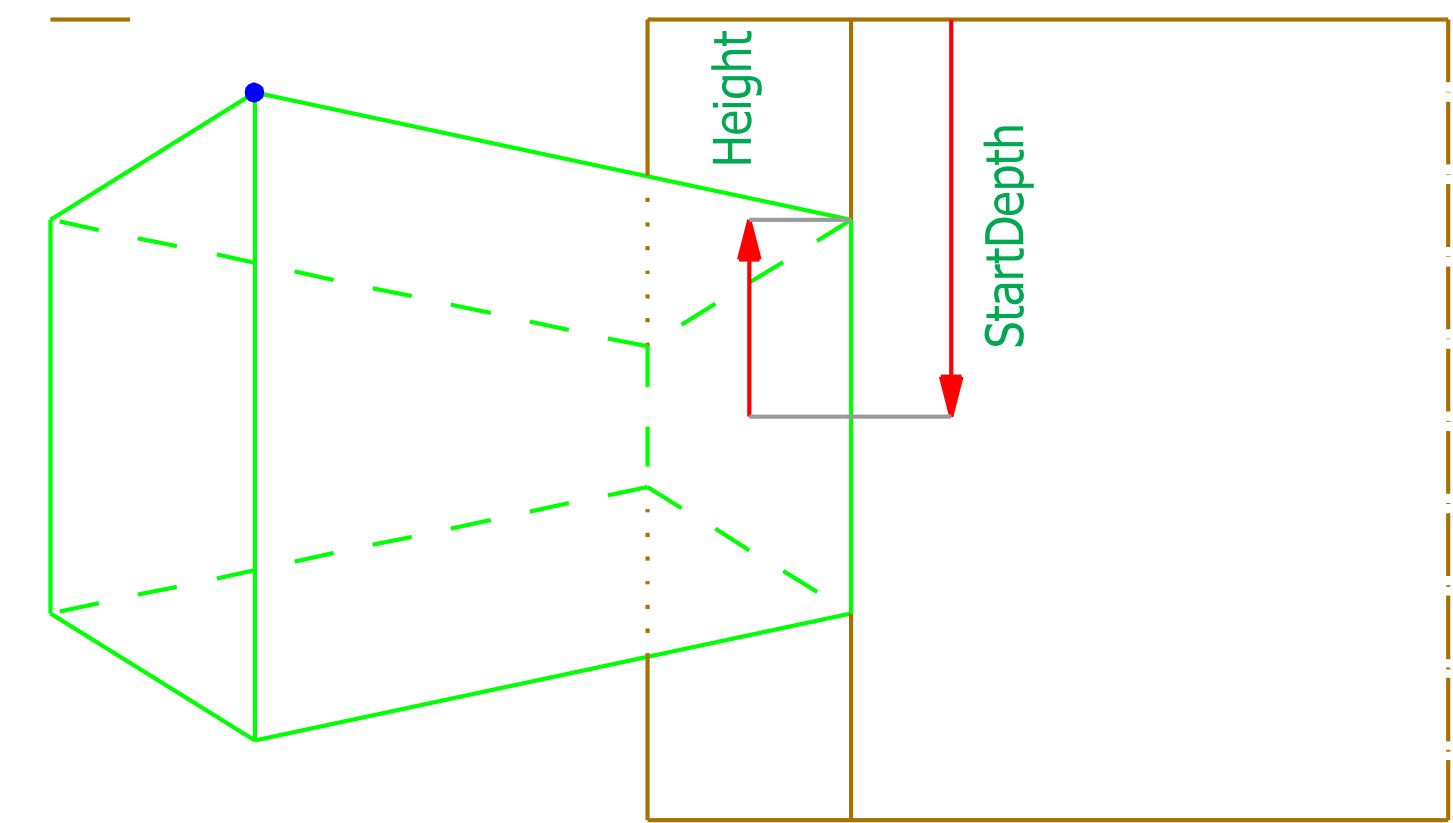
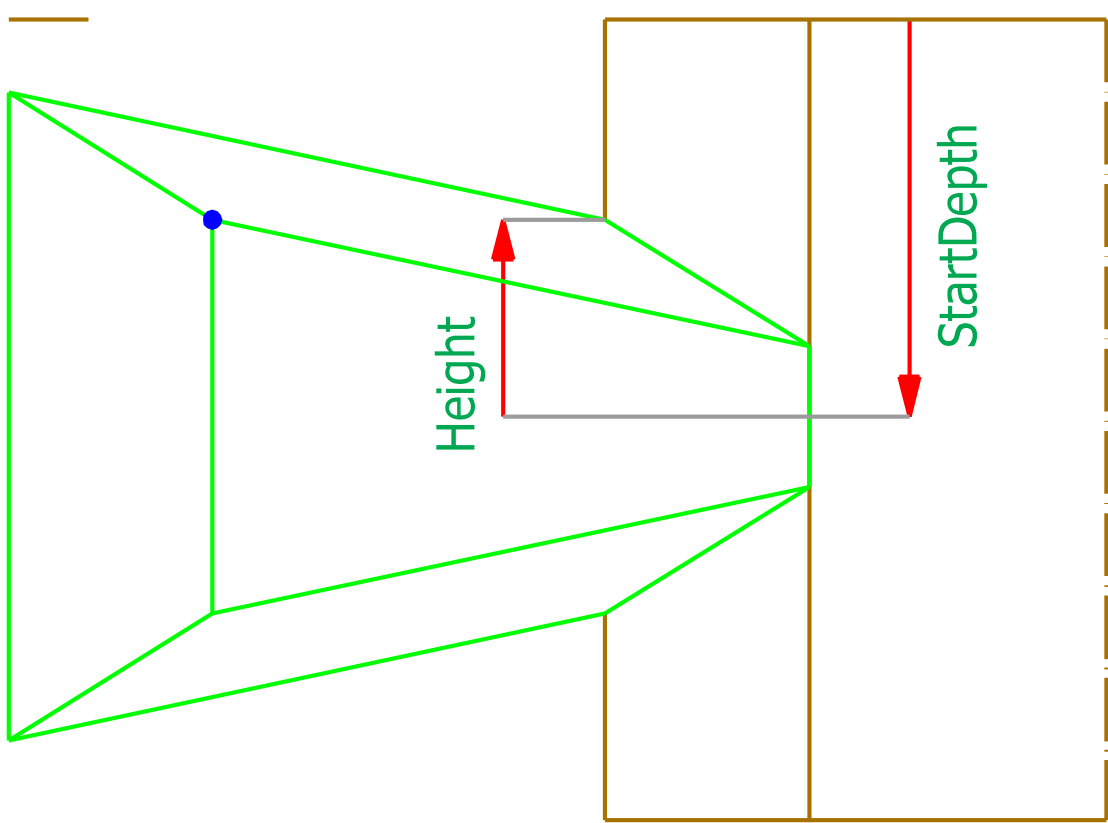
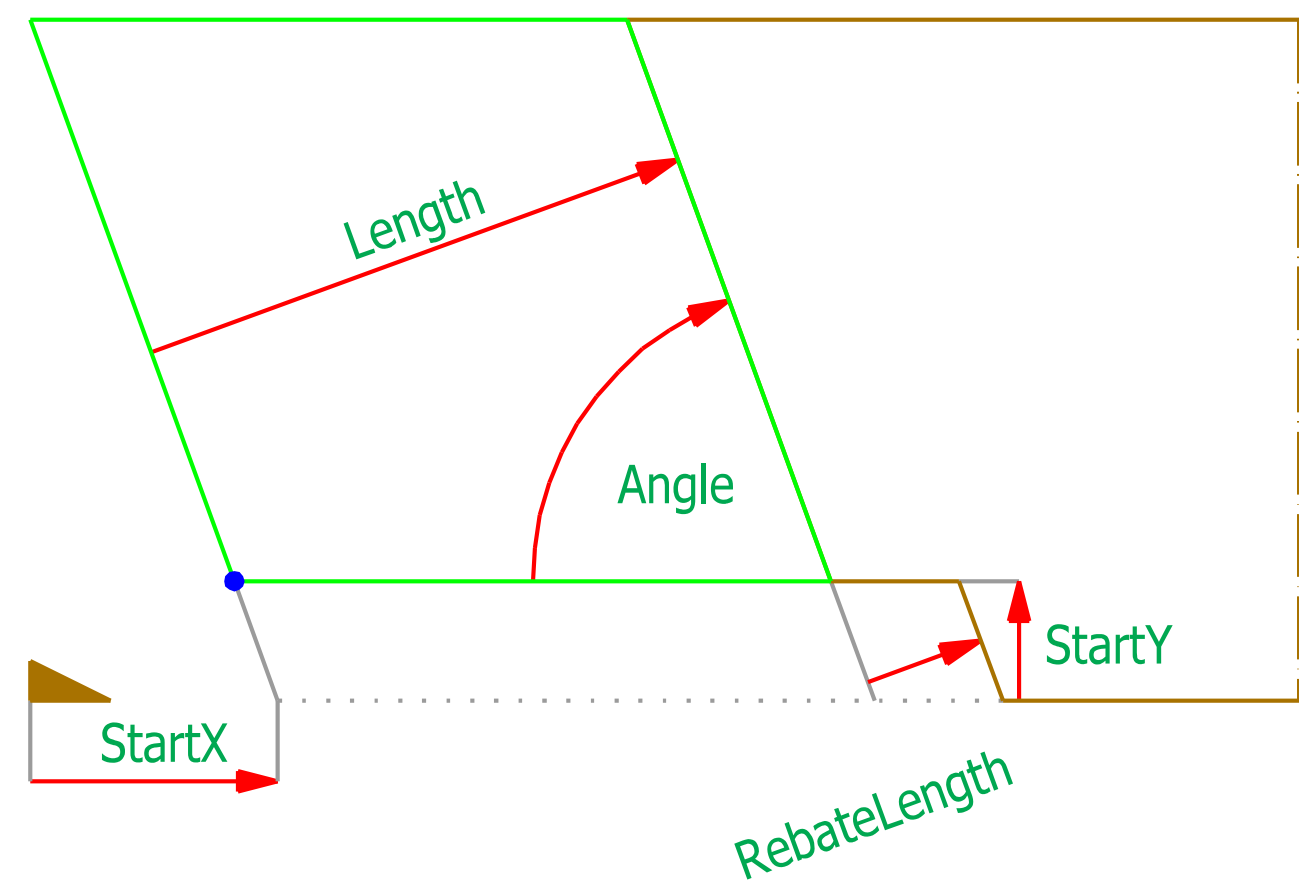
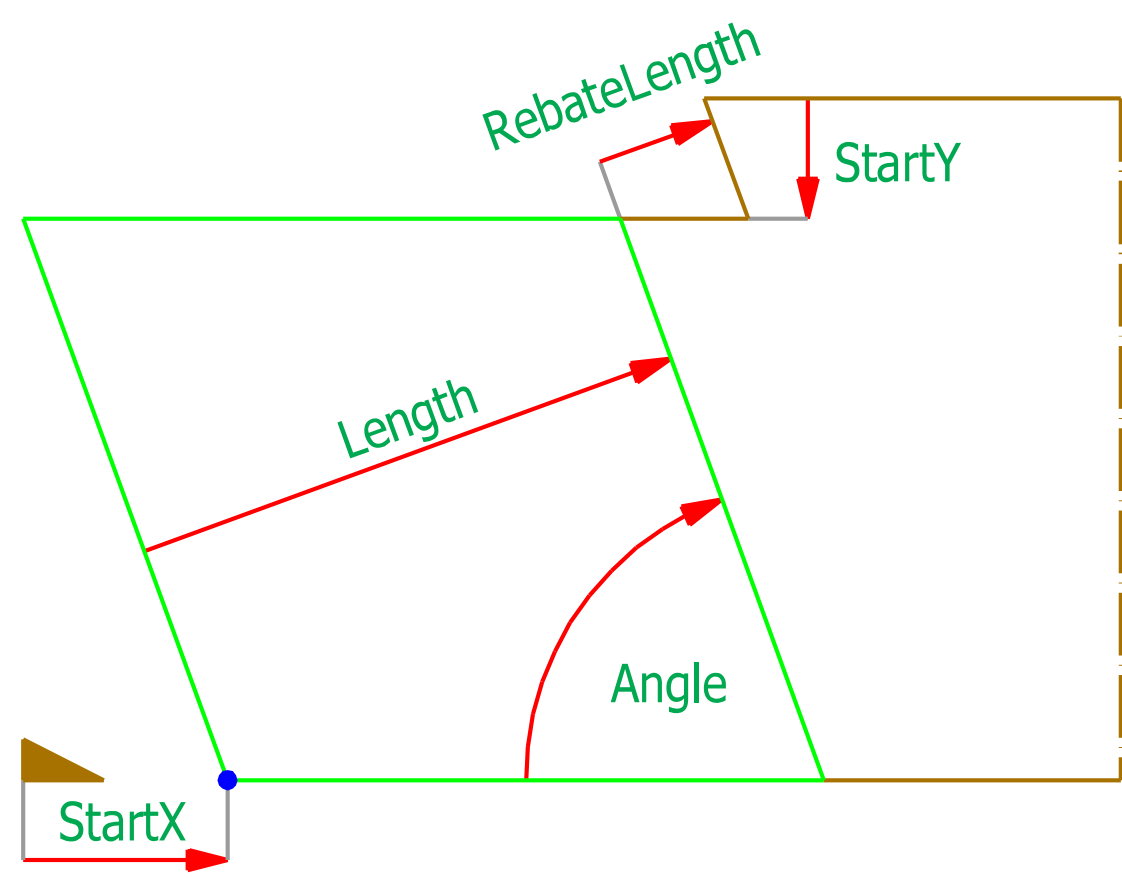
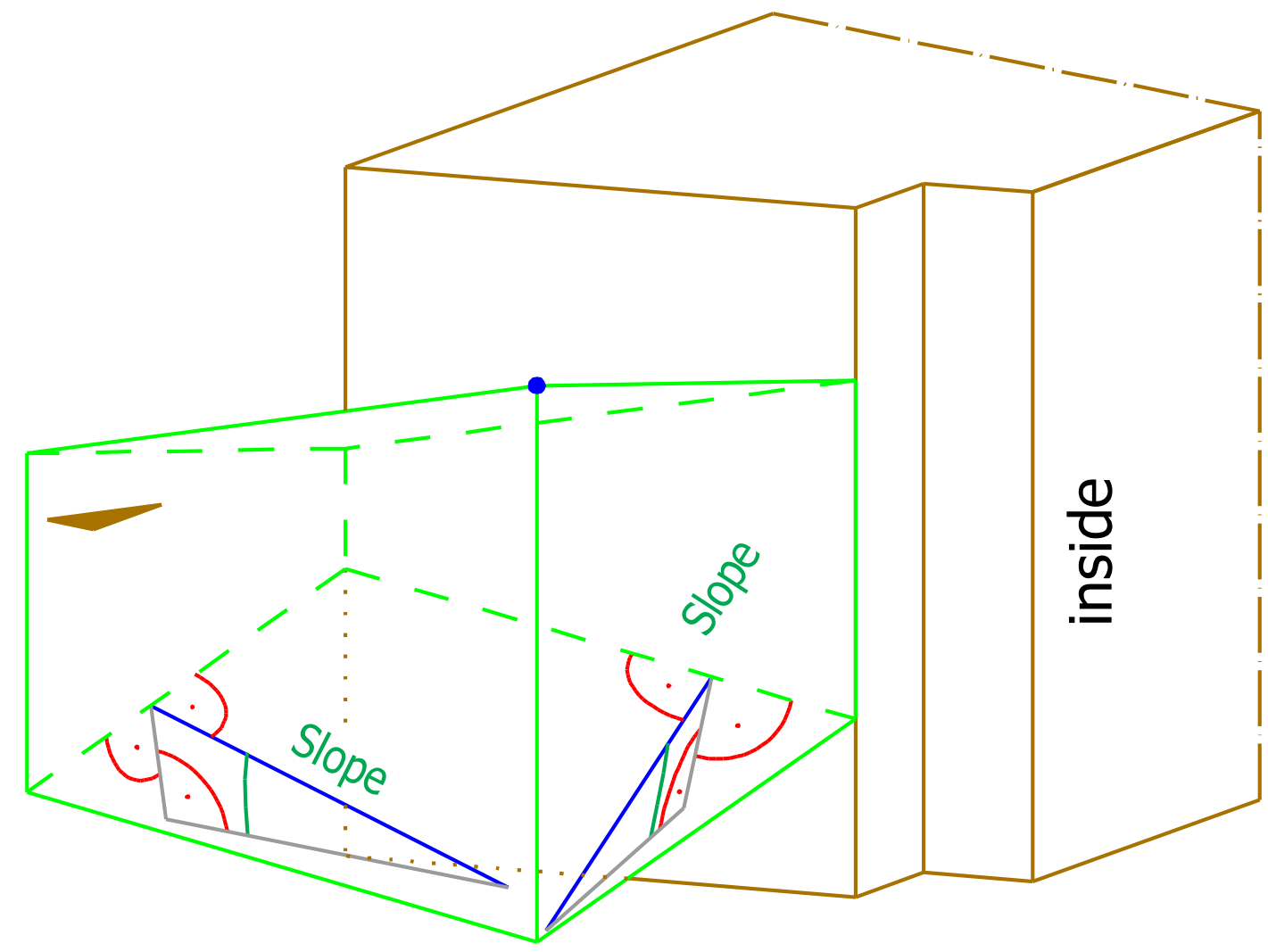
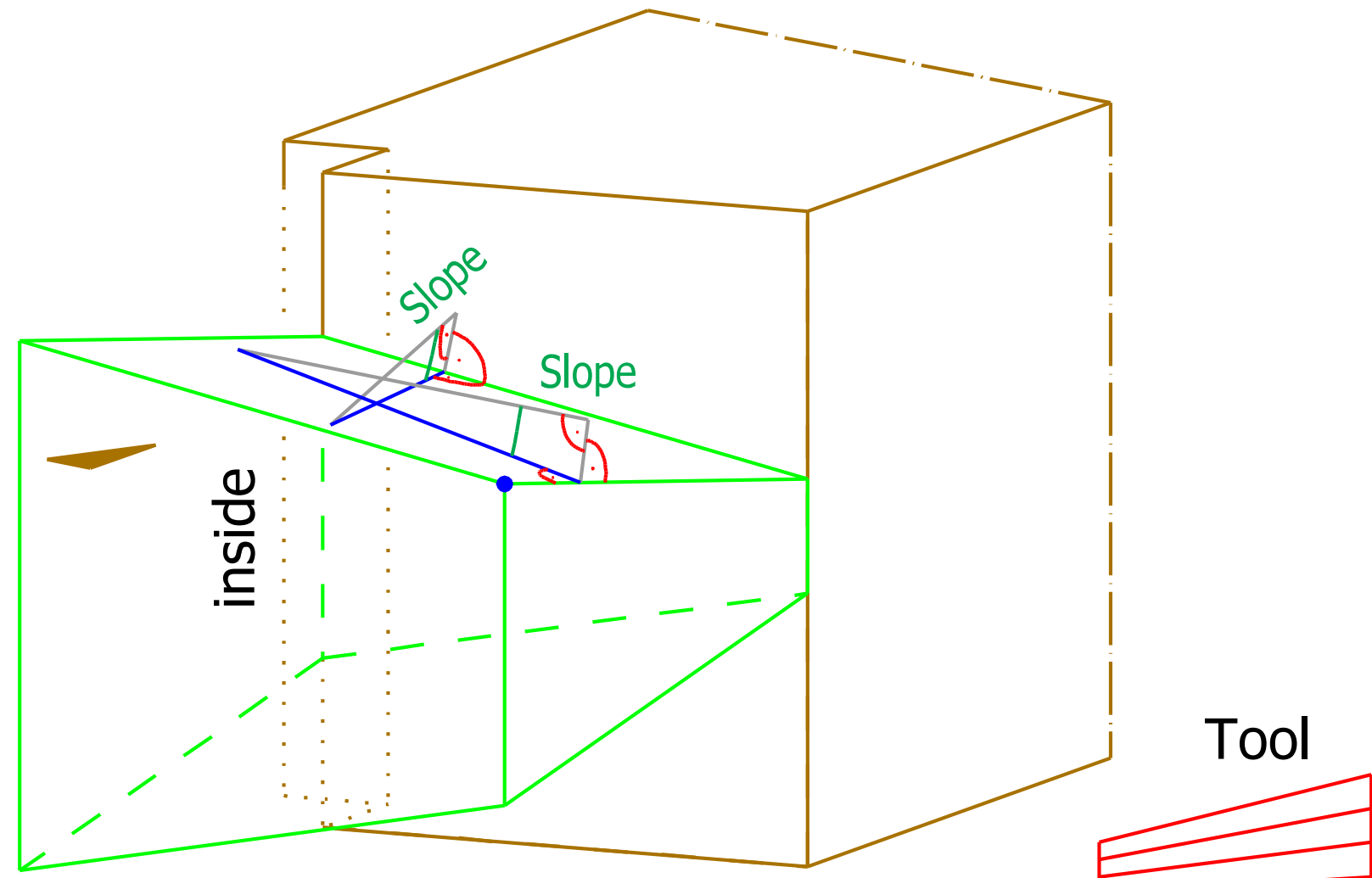

LapExit = none

LapExit = mitre

LapExit = rebate

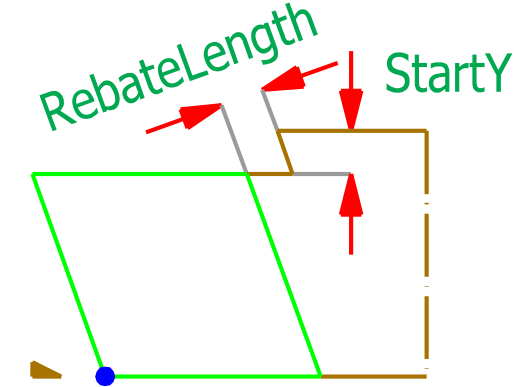
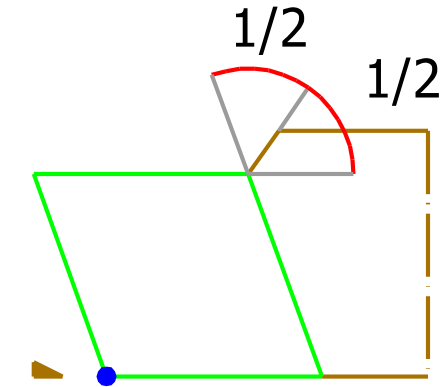
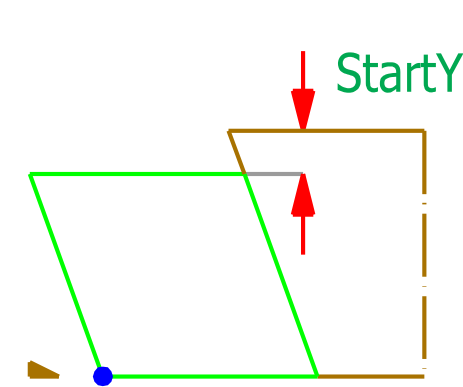

LapExit = none

LapExit = mitre

LapExit = rebate

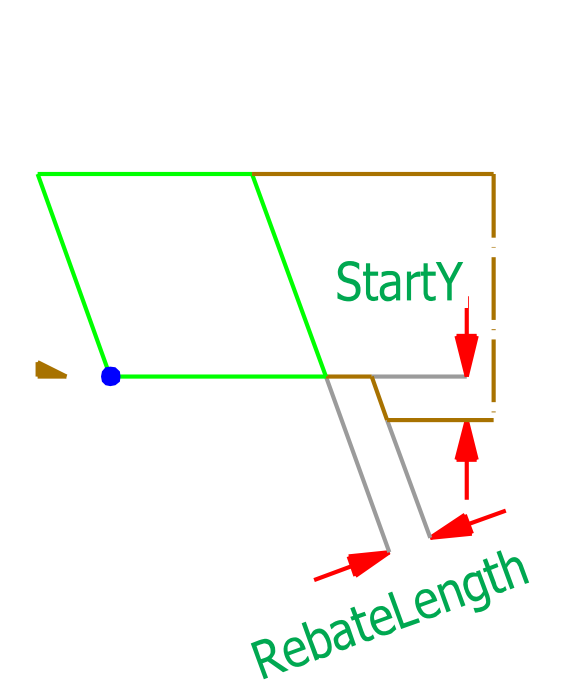
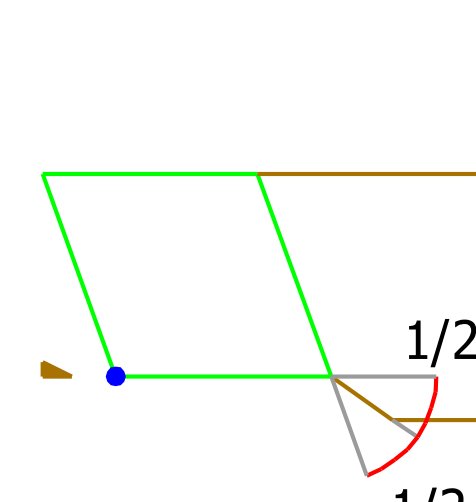
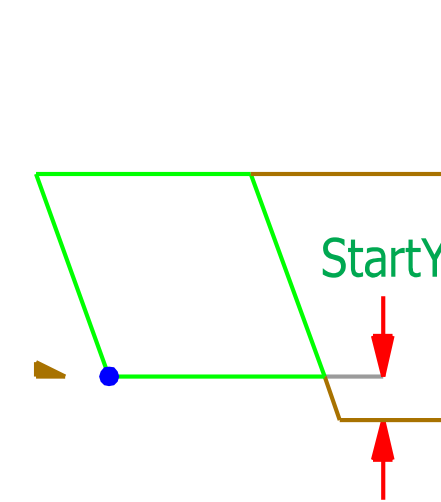

TyroleanDovetail

Orientation = start

LapPosition = refedge

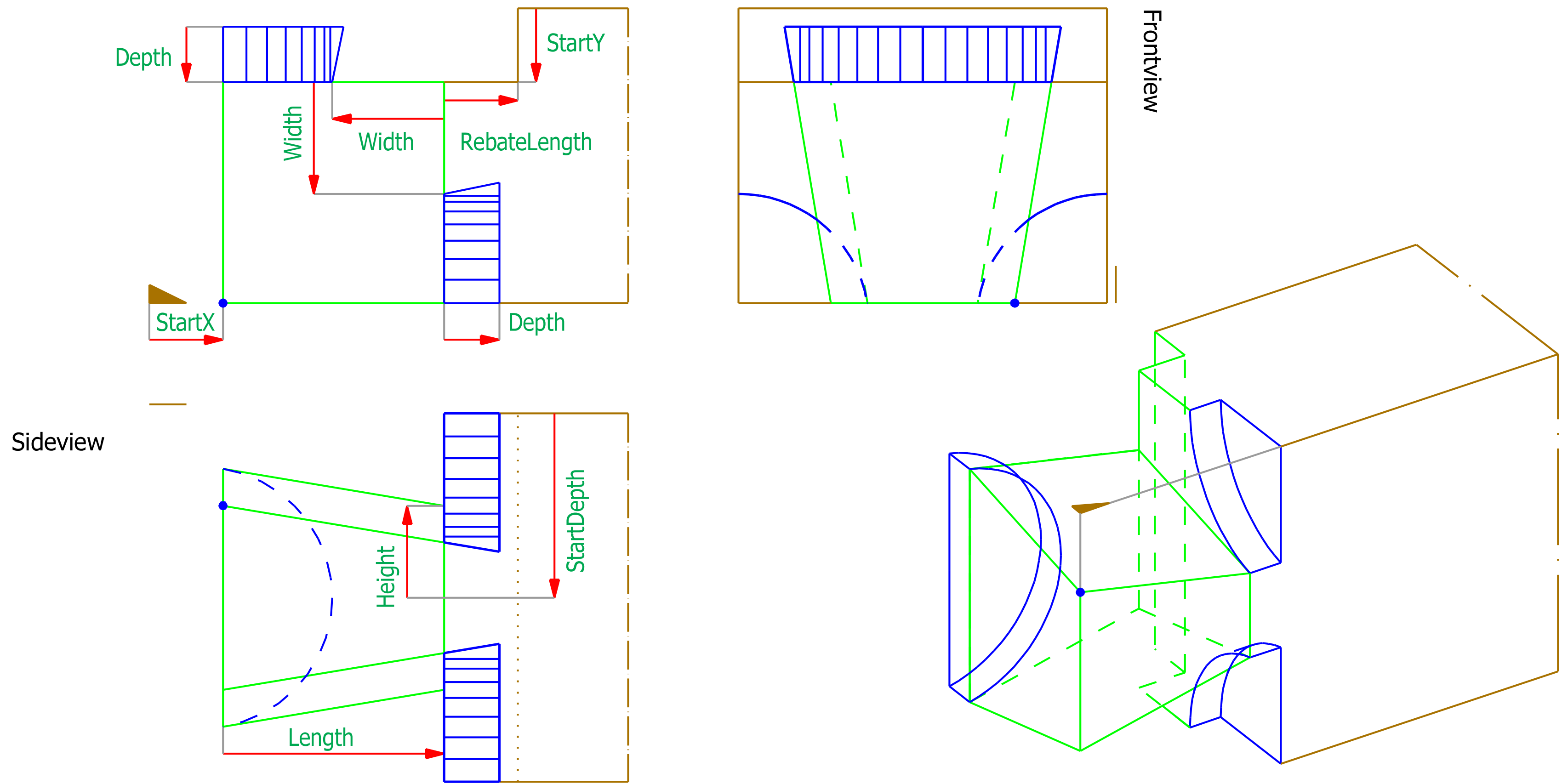

LapPosition = oppedge

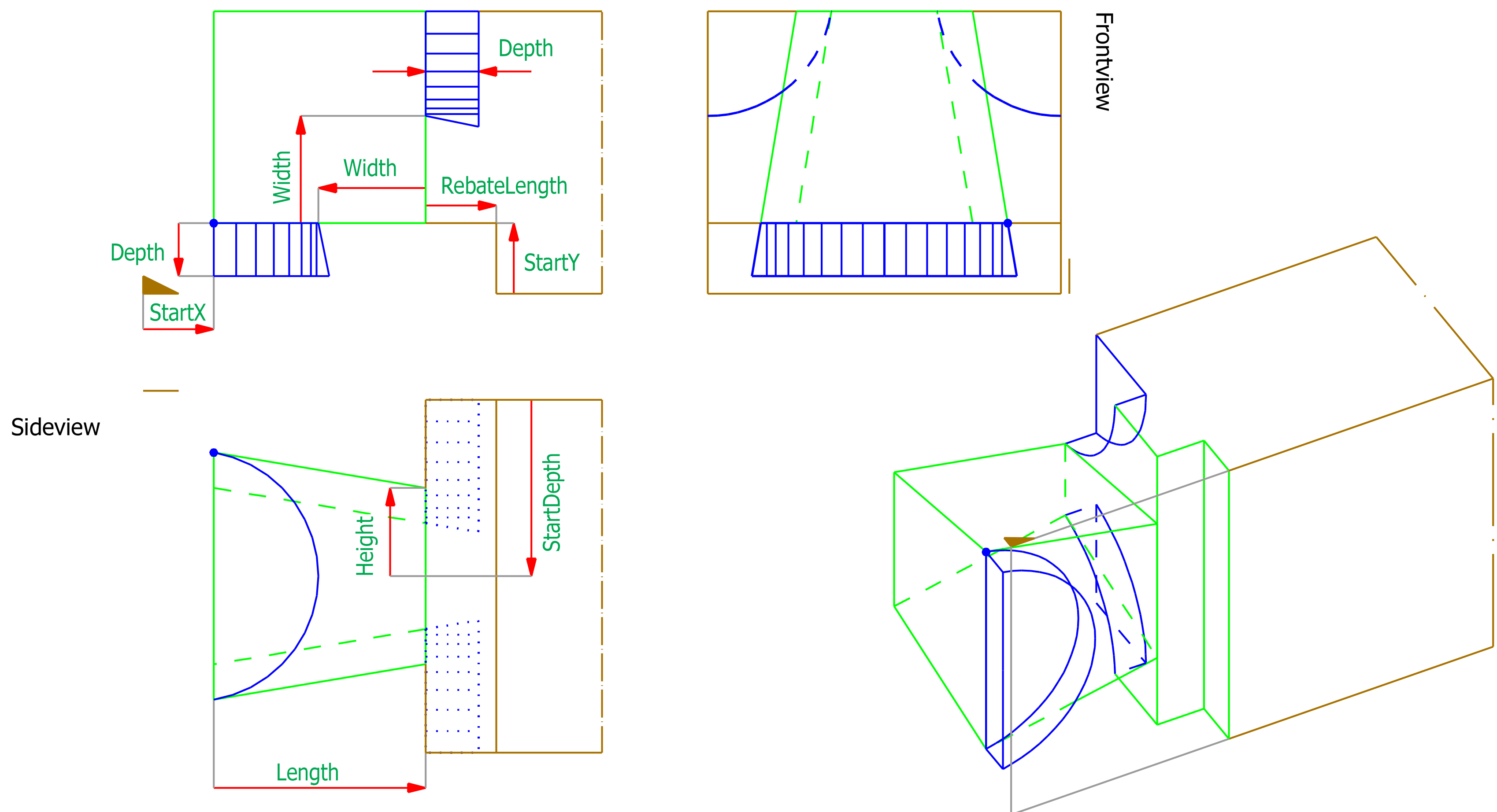

TyroleanDovetail

Orientation = start

LapPosition = refedge

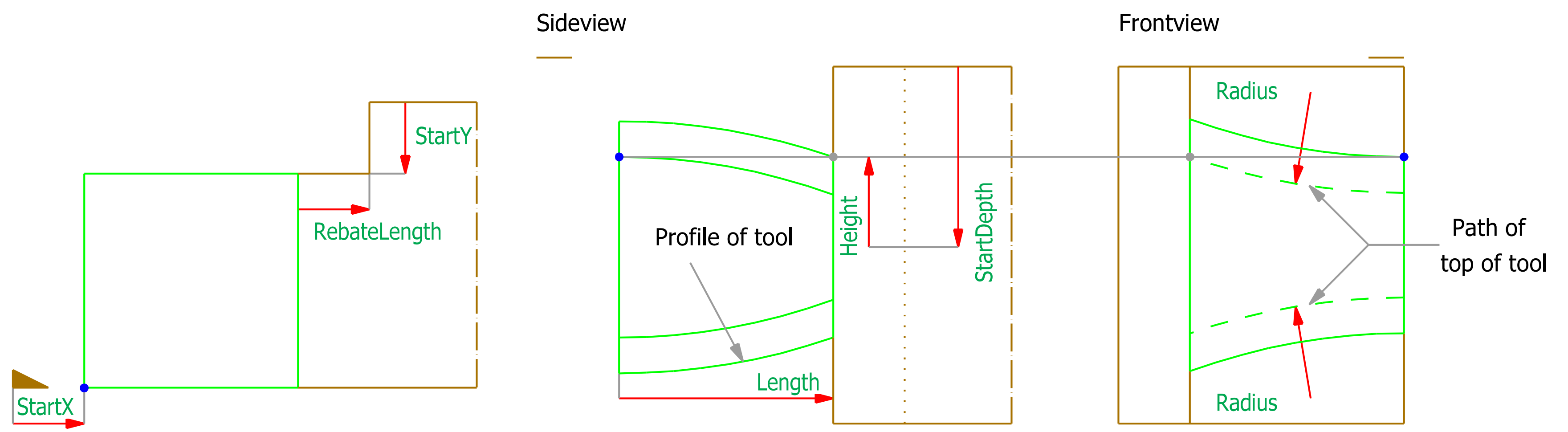

LapPosition = oppedge

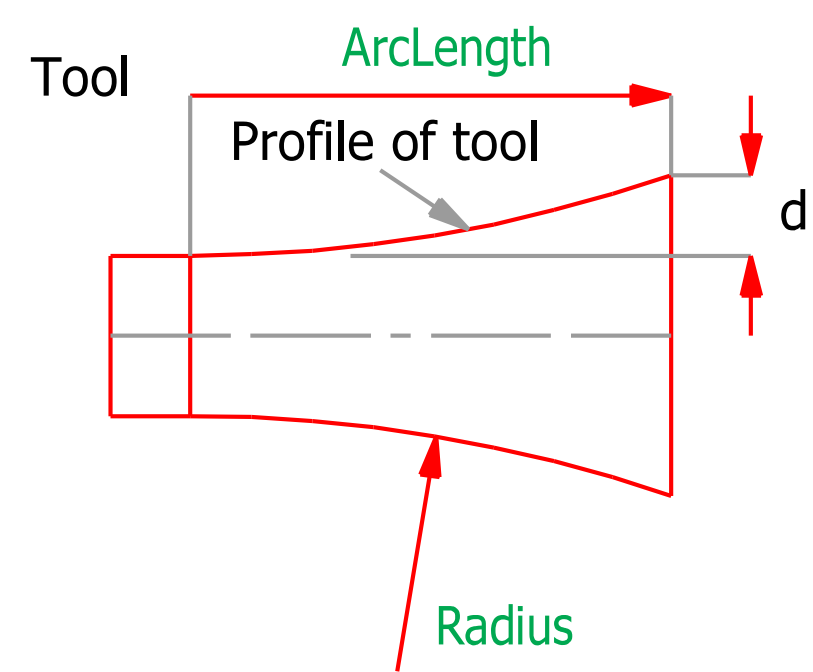
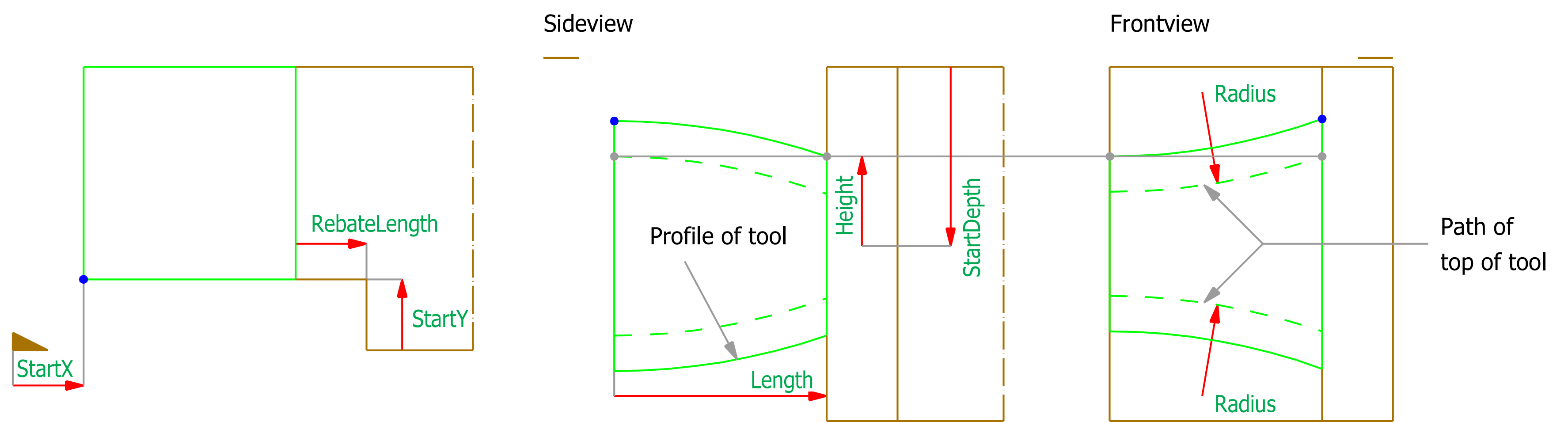

TyroleanDovetail

Orientation = end

CutOff = yes

LapPosition = refedge

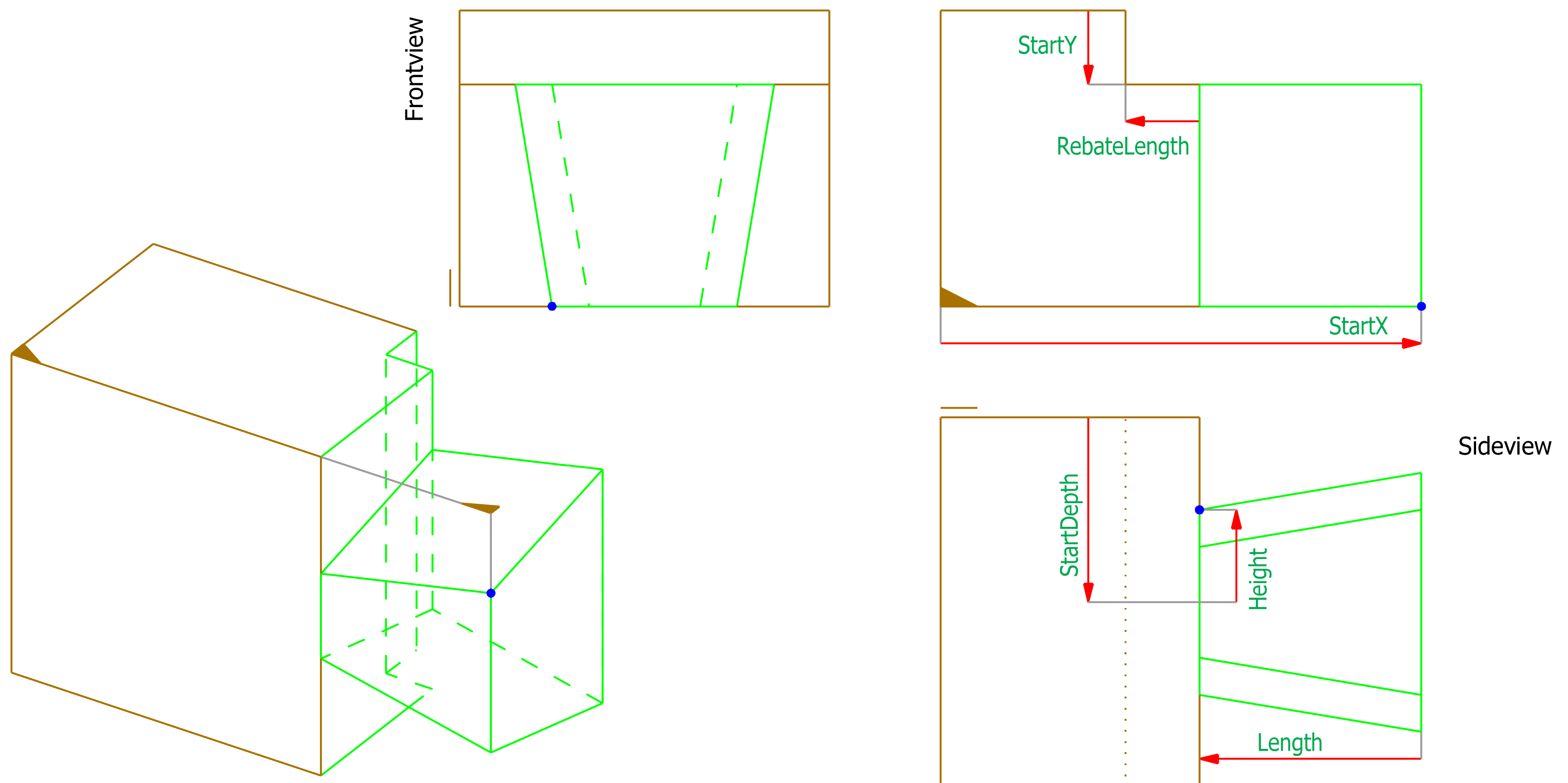

LapPosition = oppedge

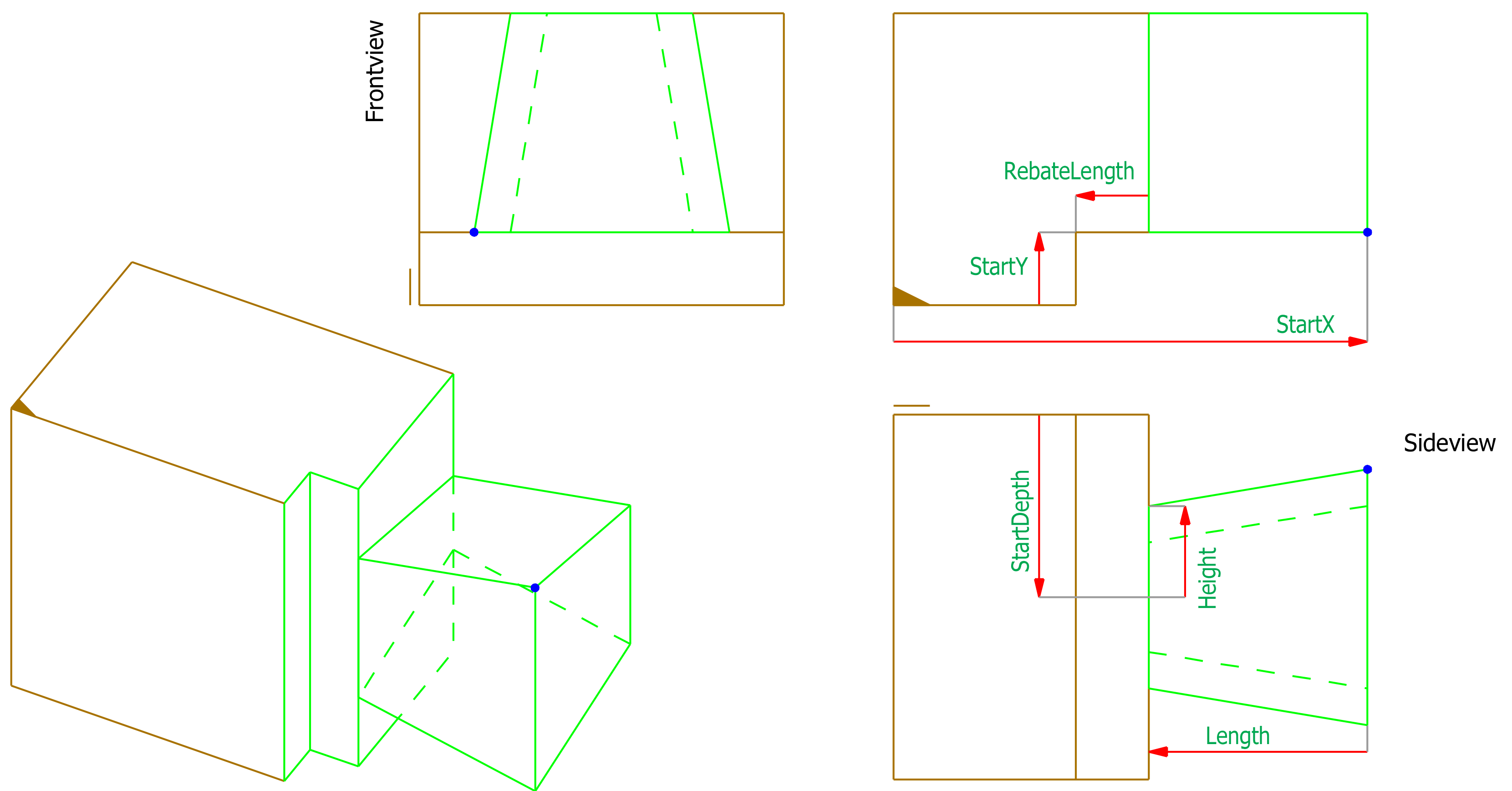

CutOff = yes

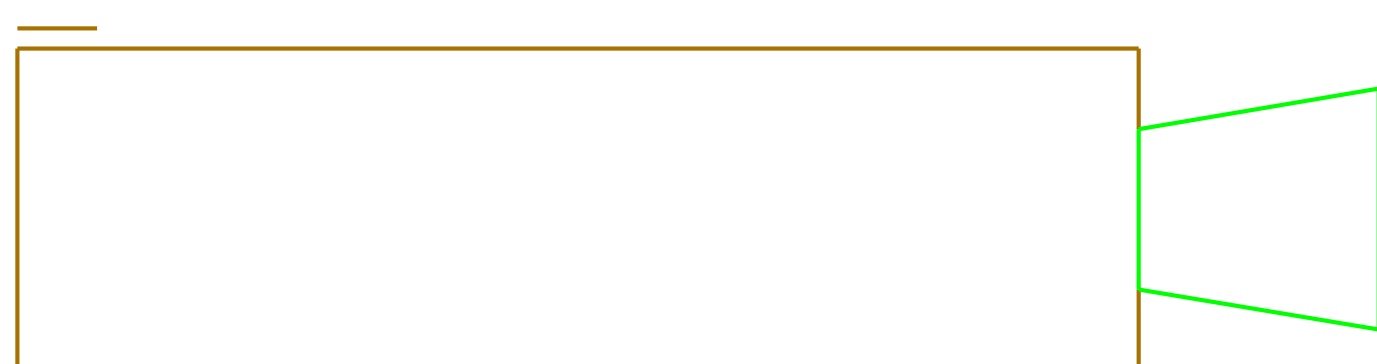

CutOff = no

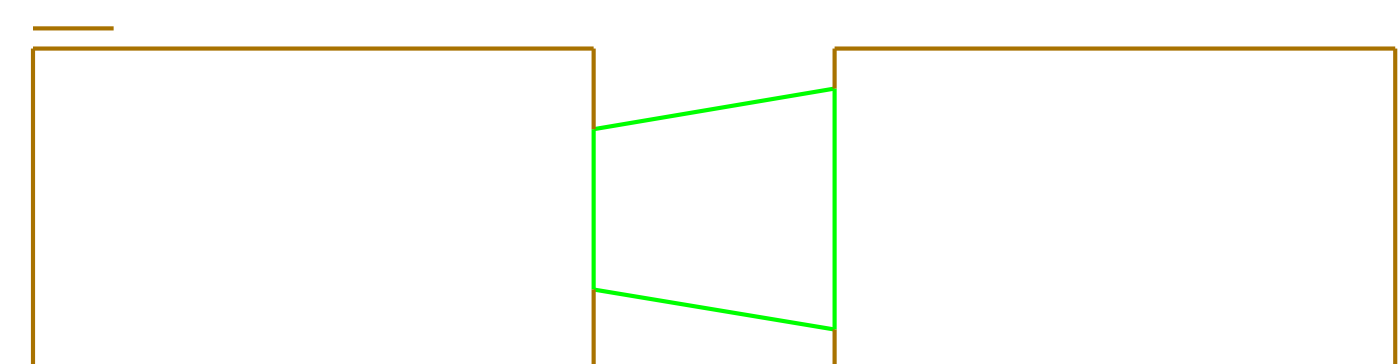

TyroleanDovetail

Orientation = end

LapPosition = refedge

LapPosition = oppedge

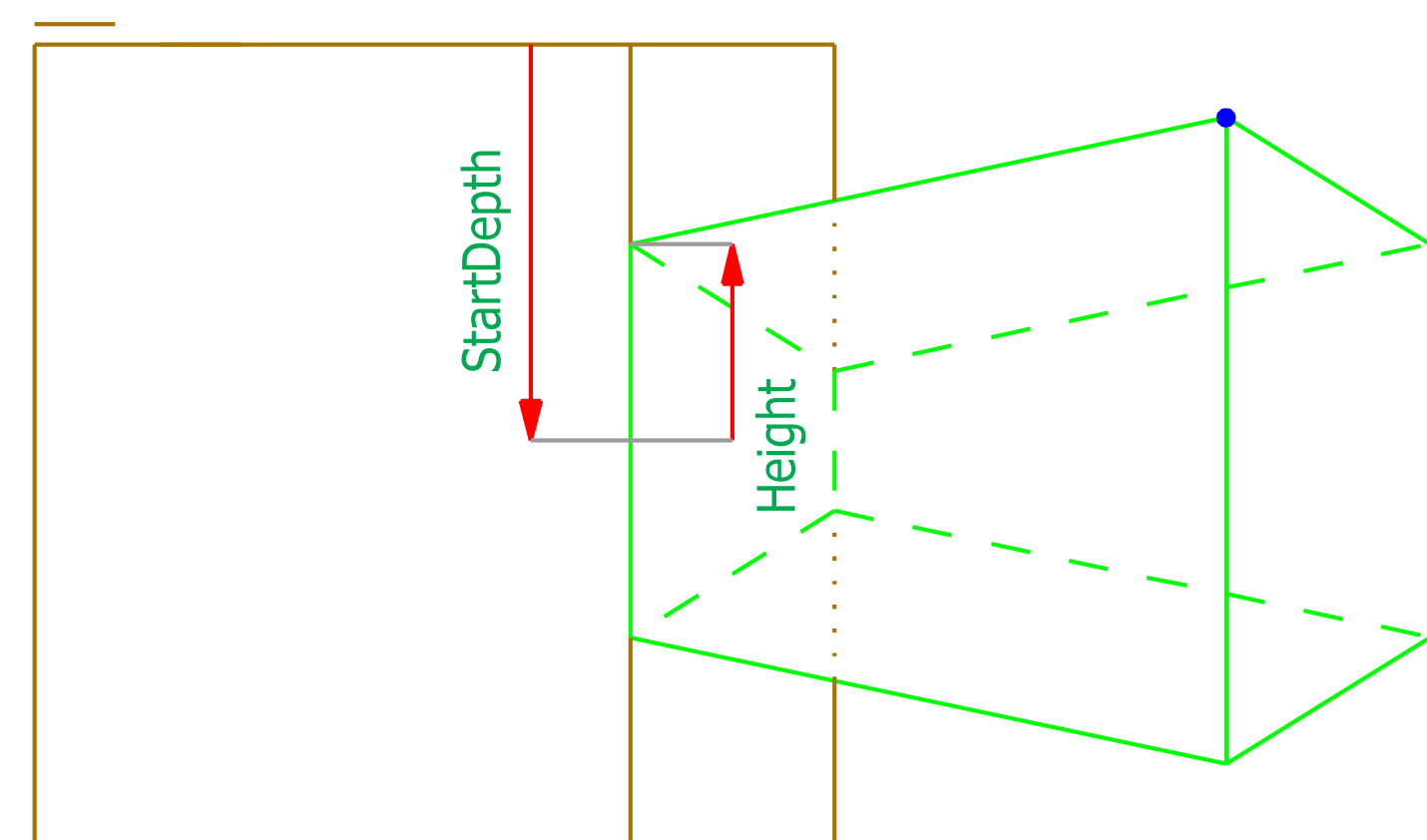
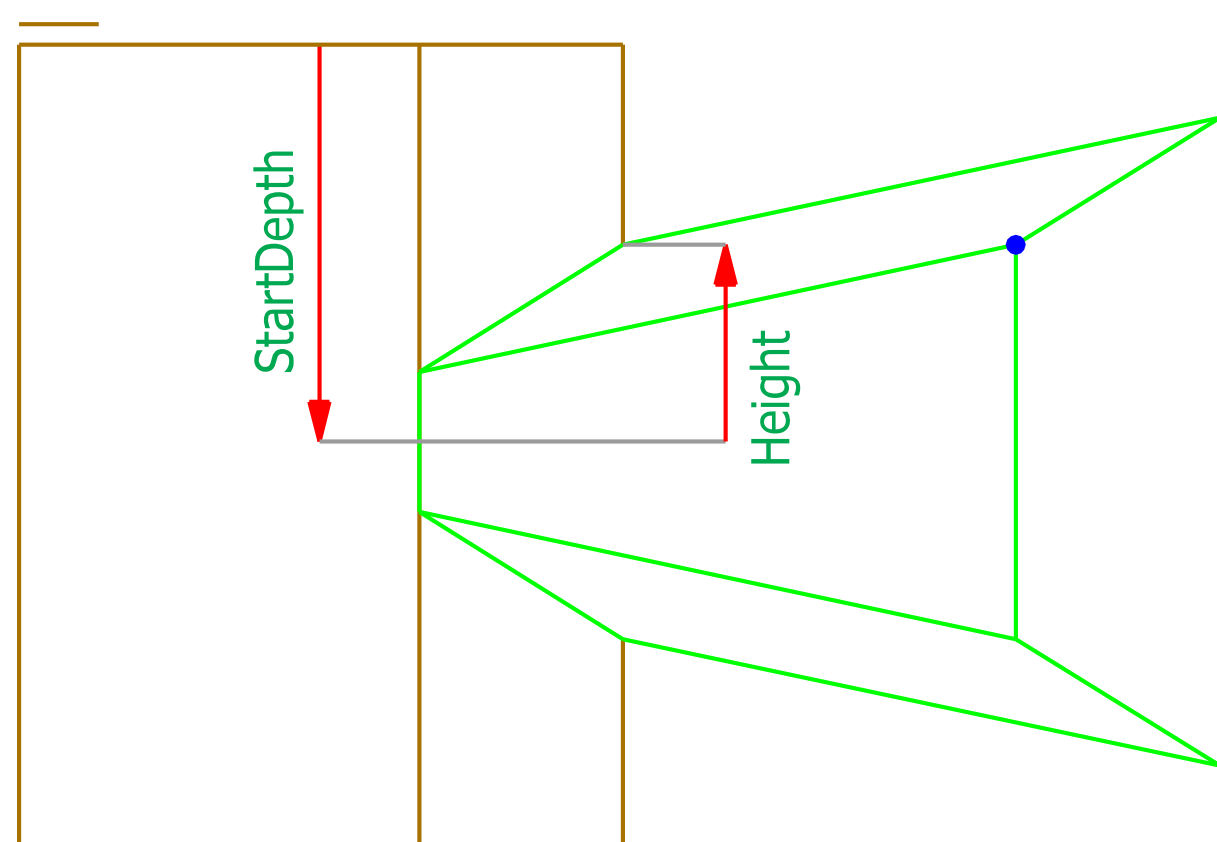
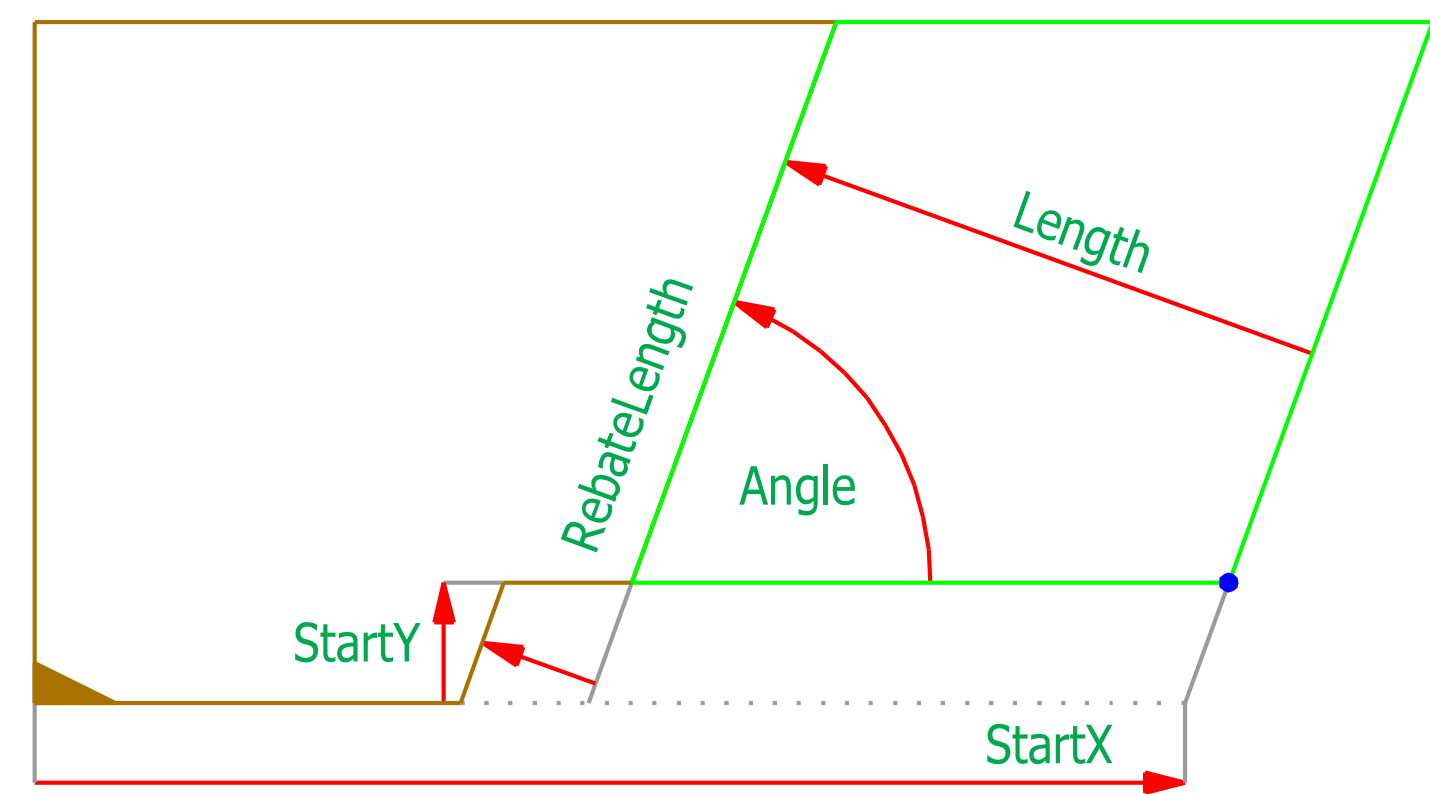
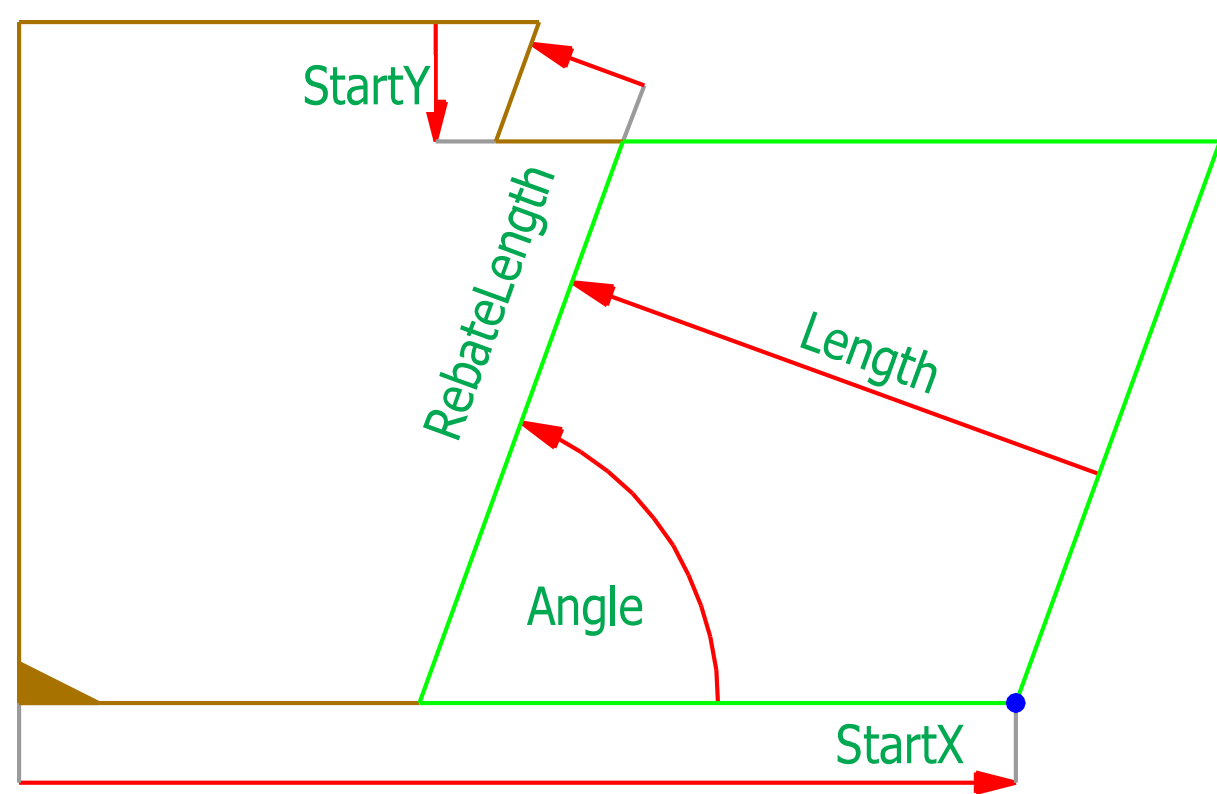
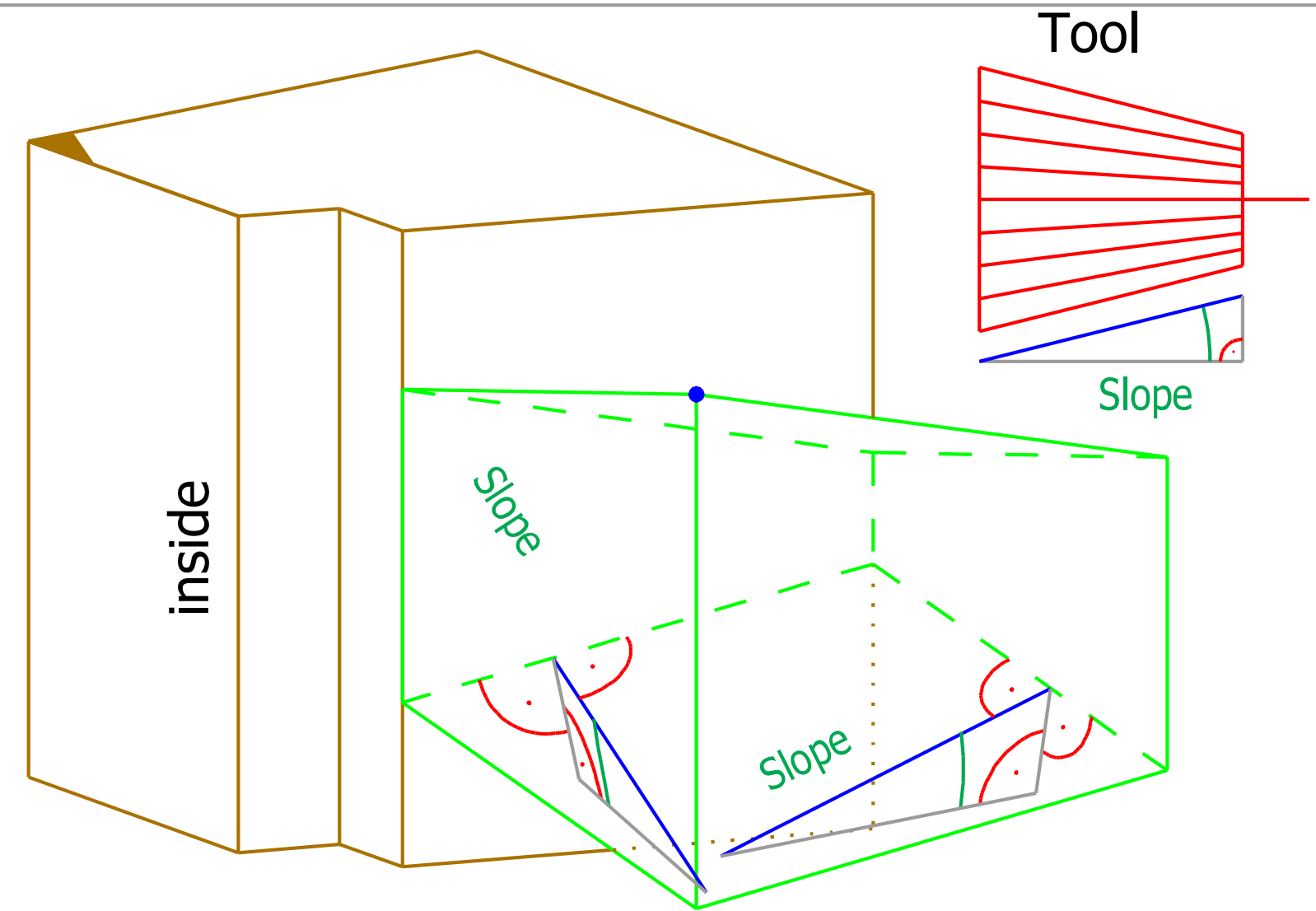
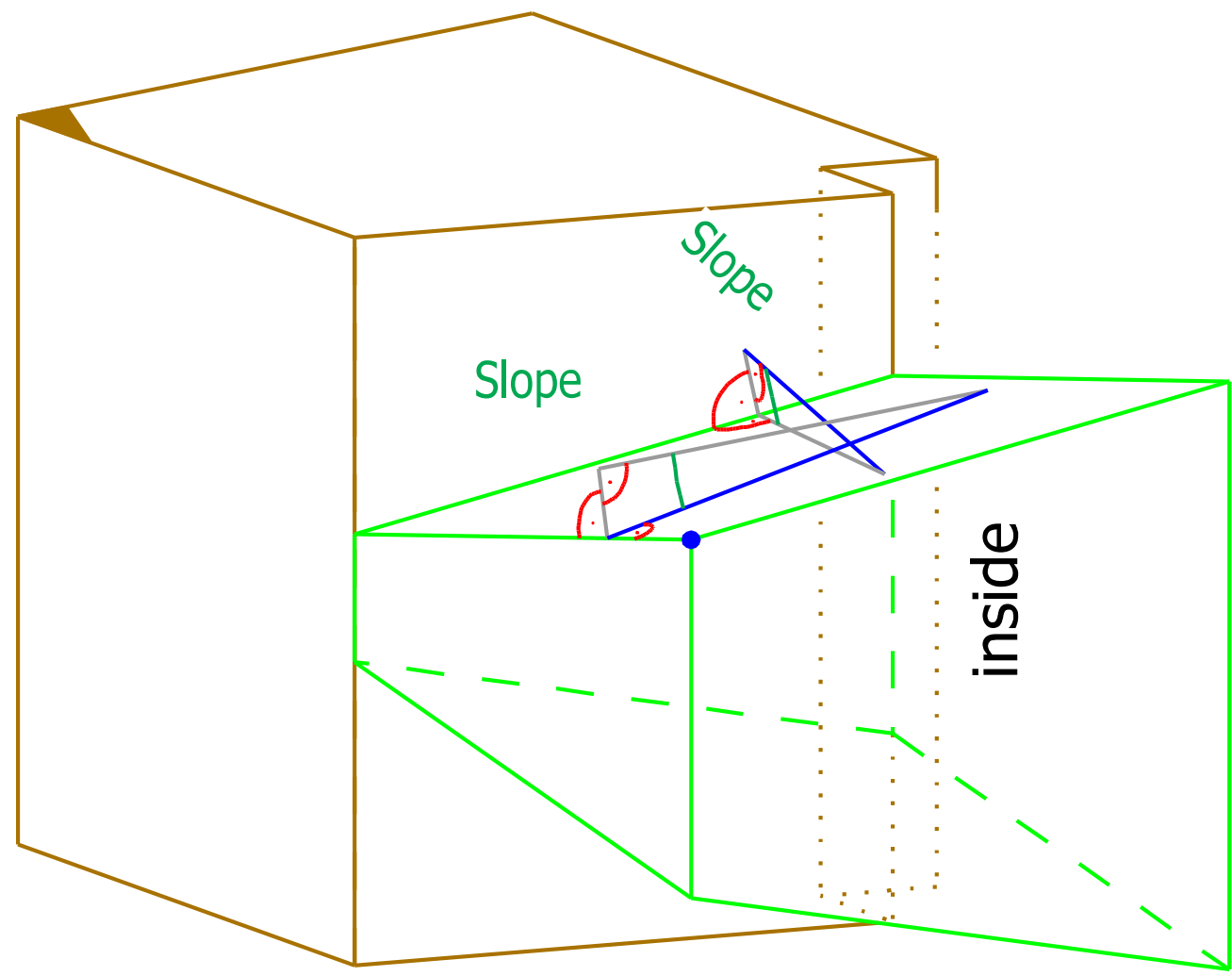

LapExit = none

LapExit = mitre

LapExit = rebate

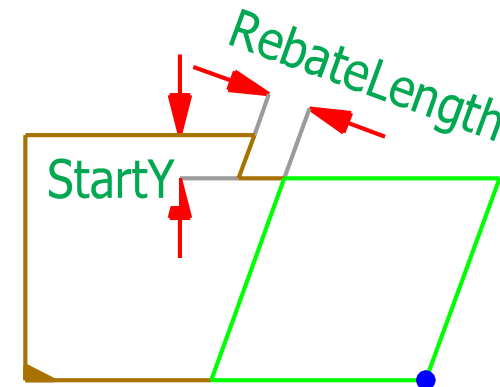
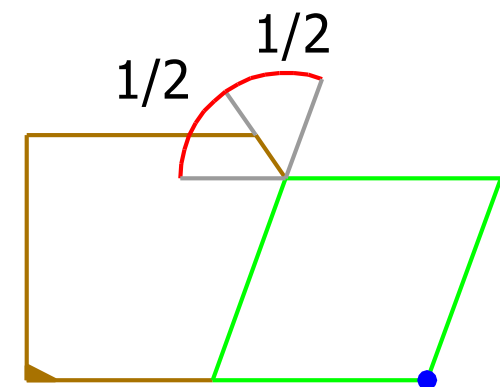
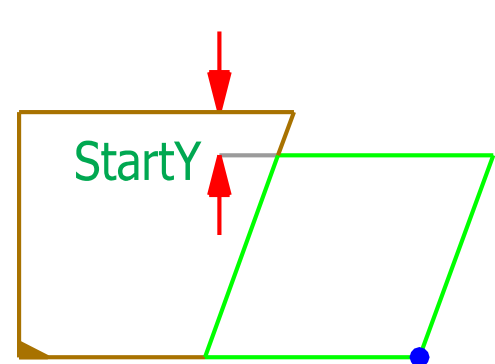

LapExit = none

LapExit = mitre

LapExit = rebate

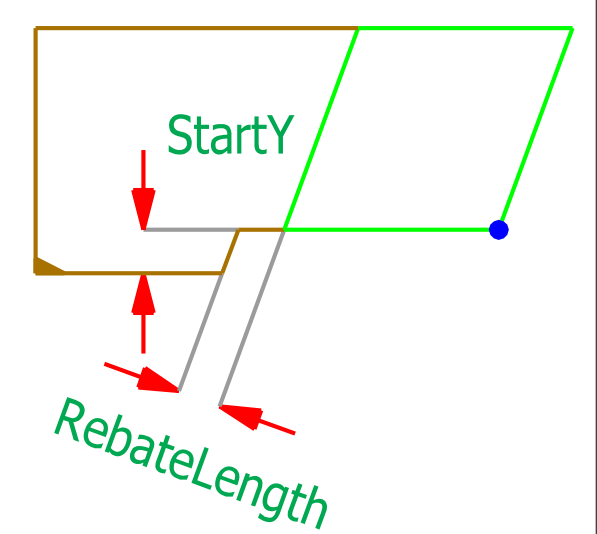
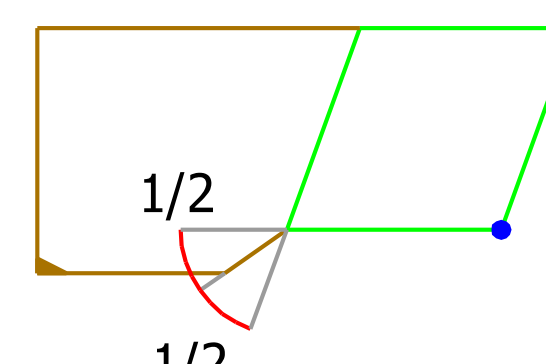
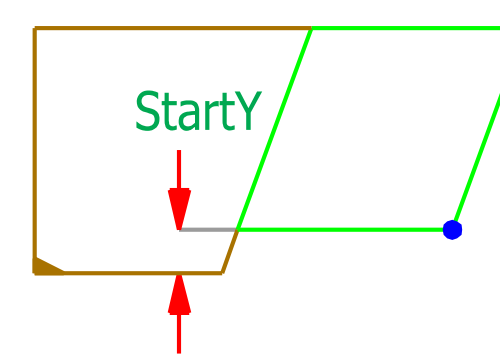

TyroleanDovetail

Orientation = end

LapPosition = refedge

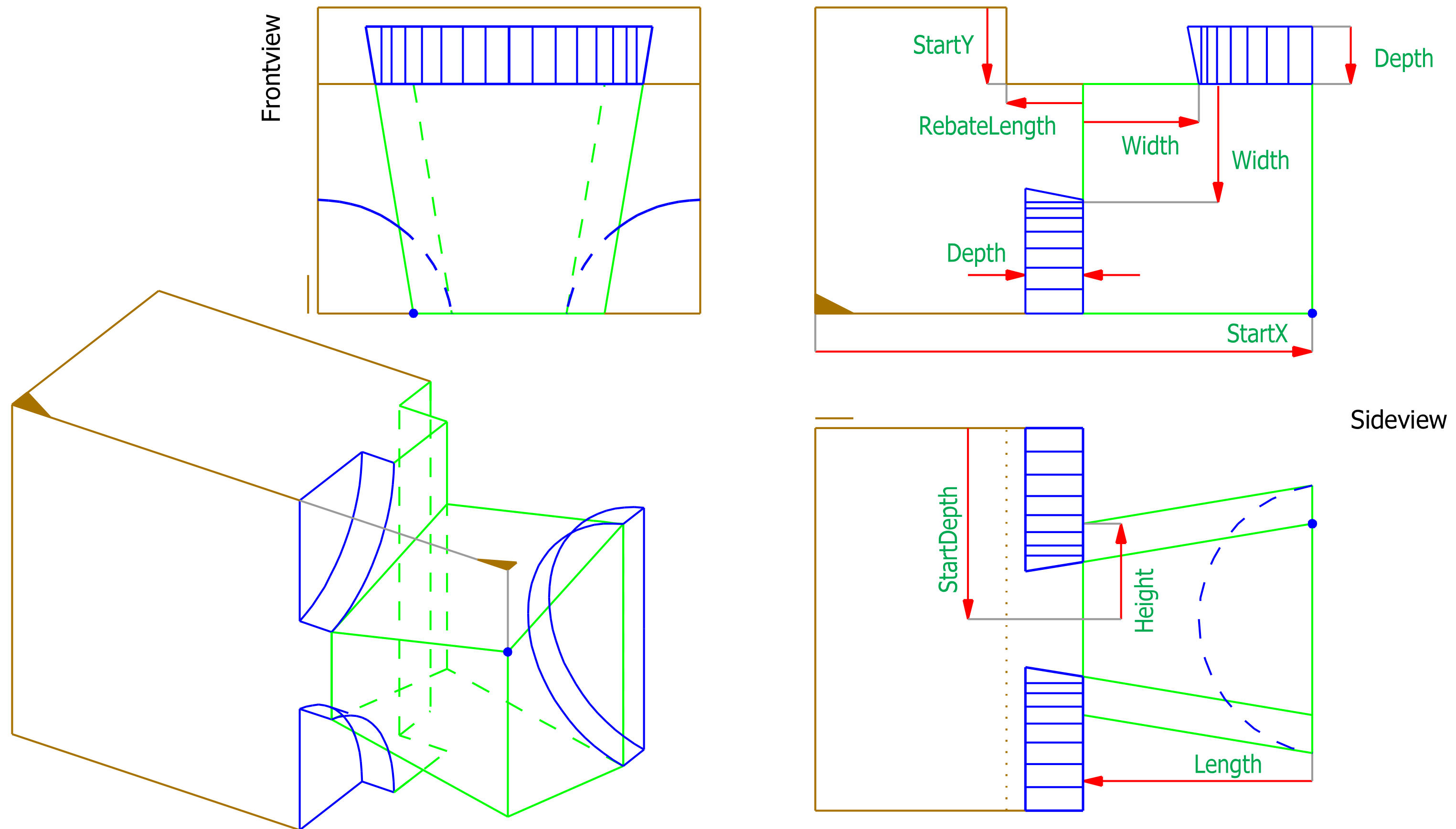

LapPosition = oppedge

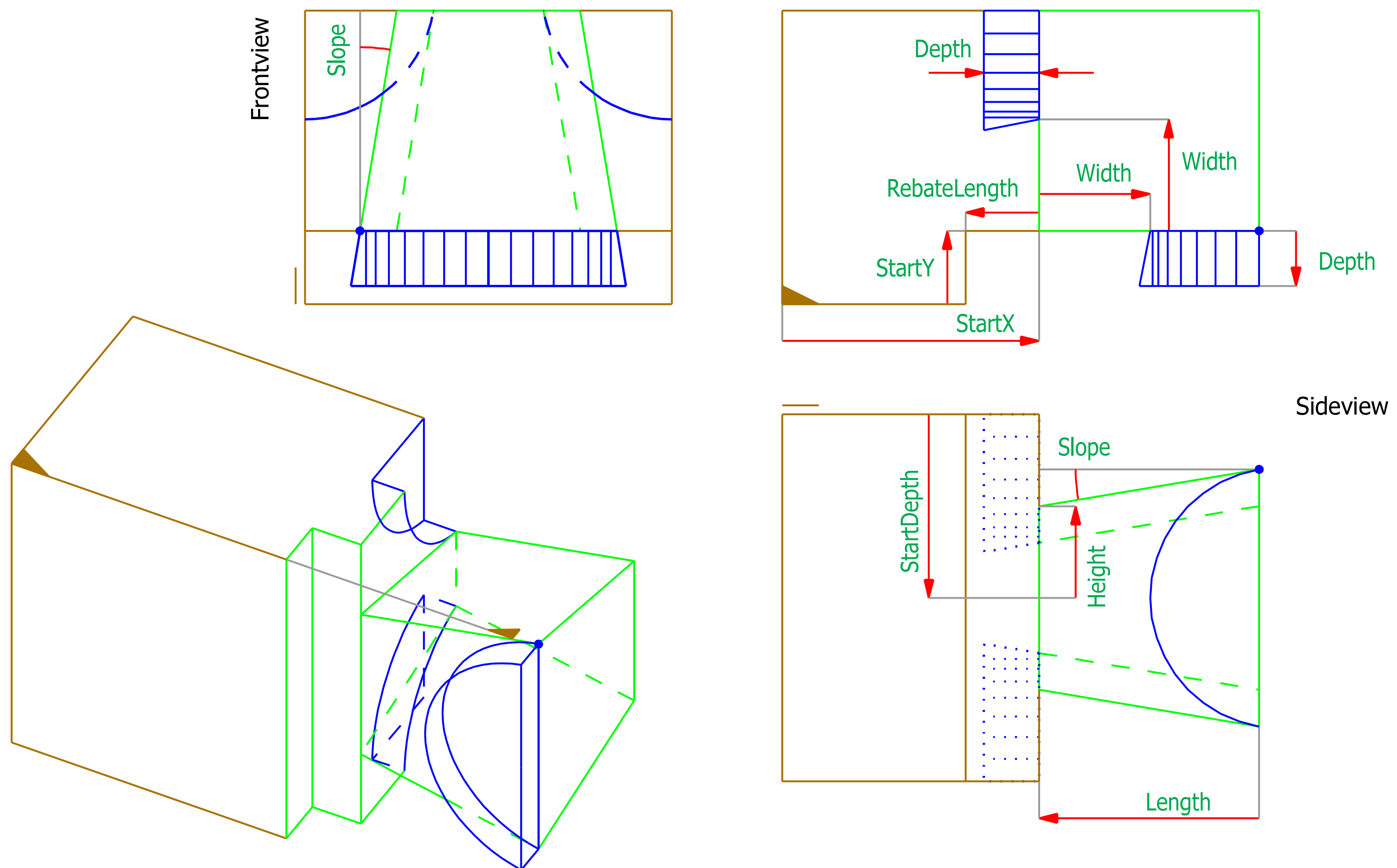

TyroleanDovetail

Orientation = end

LapPosition = refedge

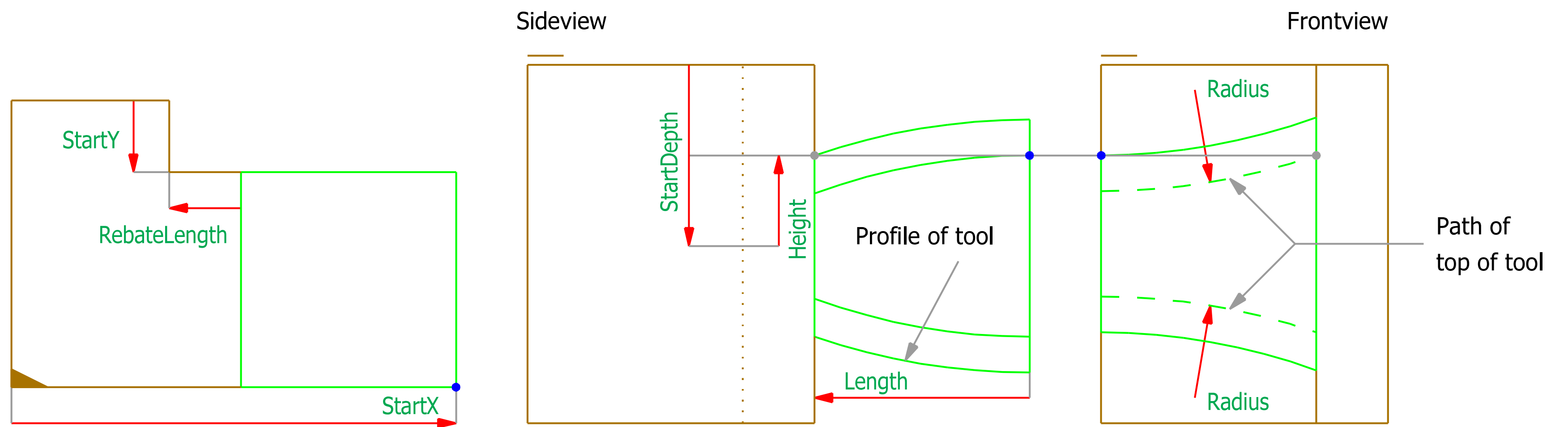

LapPosition = oppedge

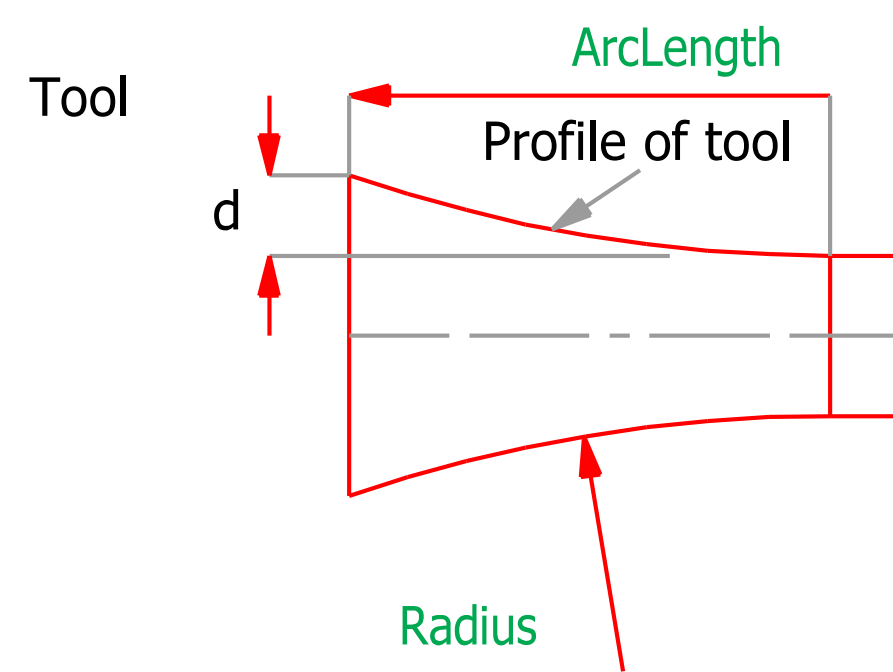
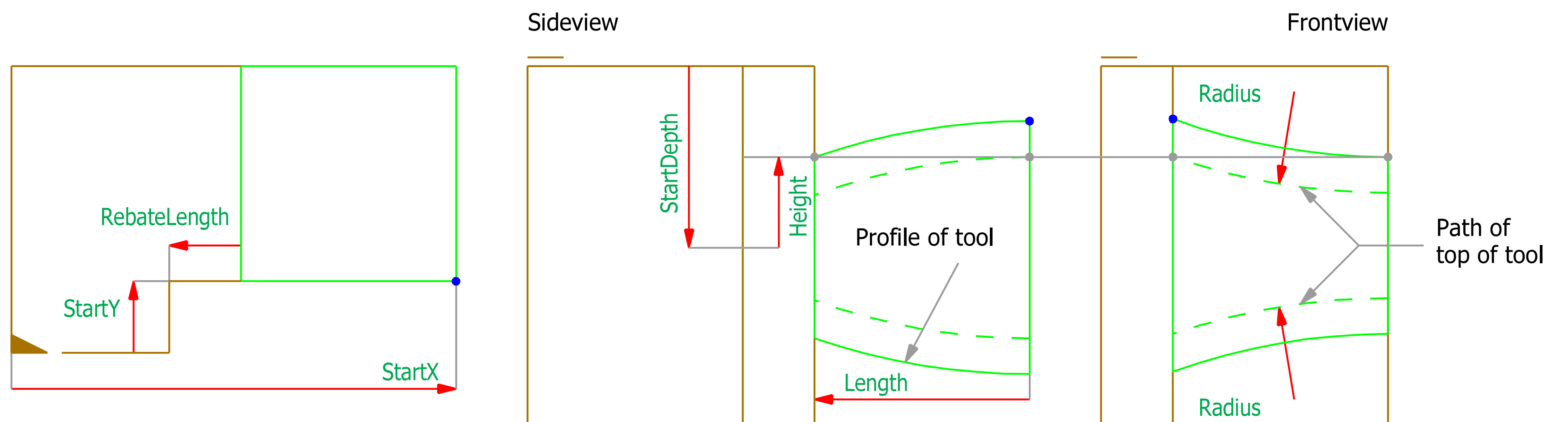

Tyrolean Dovetail

Name	Type	Default	Min	Max
Orientation	OrientationType		start	end
CutOff	BooleanType	no	no	yes
StartX	LengthPosType	0.0	-100000.0	100000.0
StartY	WidthType	30.0	0.0	50000.0
StartDepth	WidthNType	50.0	-50000.0	50000.0
Angle	AngleType		0.1	179.9
Slope	double		0.0	45.0
Length	WidthType	150.0	0.0	50000.0
RebateLength	WidthType	10.0	0.0	50000.0
Height	WidthType	60	0.0	50000.0
LapPosition	EdgePositionType	refedge	refedge/oppedge	
LapExit	LapExitType	mitre	none/mitre/rebate	
Shape	TyroleanDovetailShapeType	angular	angular/straight	
ProcessSide	ProcessSideType	both	both/refside/oppside	

Frosch

Name	Type	Default	Min	Max
Width	WidthType			
Depth	WidthType			

Klingschrot

Name	Type	Default	Min	Max
Radius	WidthType			
ArcLength	WidthType			